

**MANUAL OF UNIFORM MINIMUM STANDARDS
FOR DESIGN, CONSTRUCTION, AND MAINTENANCE
FOR STREETS AND HIGHWAYS**

(Commonly known as the "Florida GreenBook")

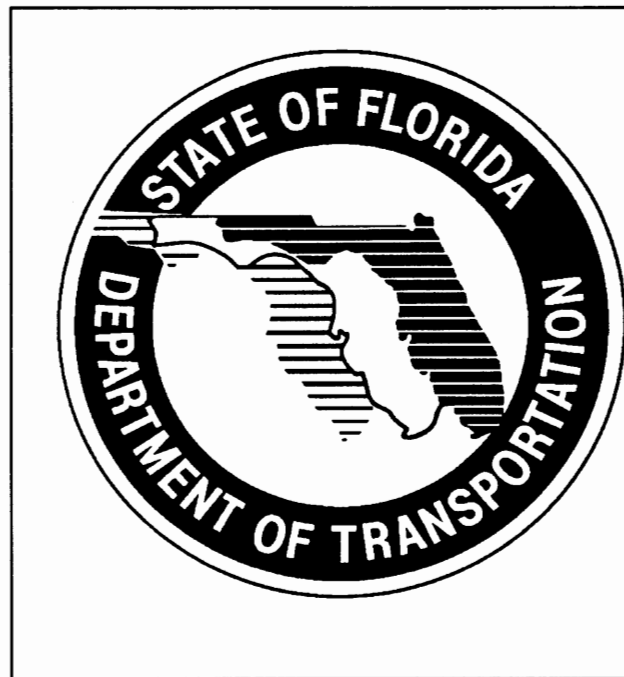

STATE OF FLORIDA

DEPARTMENT OF TRANSPORTATION

TALLAHASSEE, FLORIDA

**MAY - 2001
EDITION**

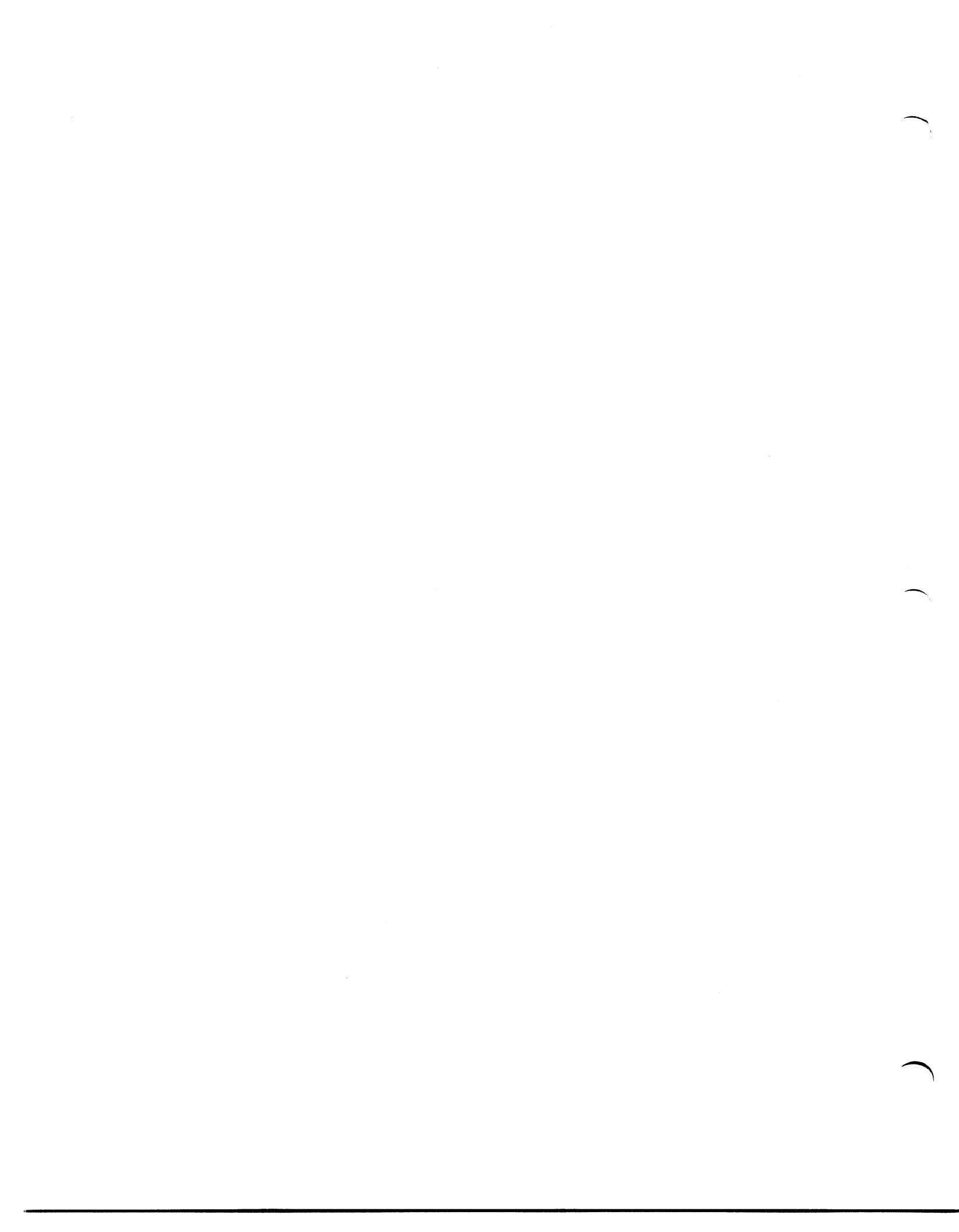

MAY- 2001
EDITION

To: "MANUAL OF UNIFORM MINIMUM STANDARDS" USERS

In order to ensure you will receive all changes or additions to this Manual, please complete the following. **ONLY** this **original** page out of your Manual will be accepted and filed as registered. Copies, etc., will not be considered for registration.

Please print or type complete mailing address

COMPANY: _____

MANUAL HOLDER: _____

ADDRESS: _____

CITY: _____

STATE: _____

ZIP: _____

PHONE: _____

FAX: _____

EMAIL: _____

Please return this original sheet to:

STATE ROADWAY DESIGN OFFICE
605 SUWANNEE STREET - MS #32
TALLAHASSEE, FLORIDA 32399-0450

ANY QUESTIONS PLEASE CALL: (850) 414-4310

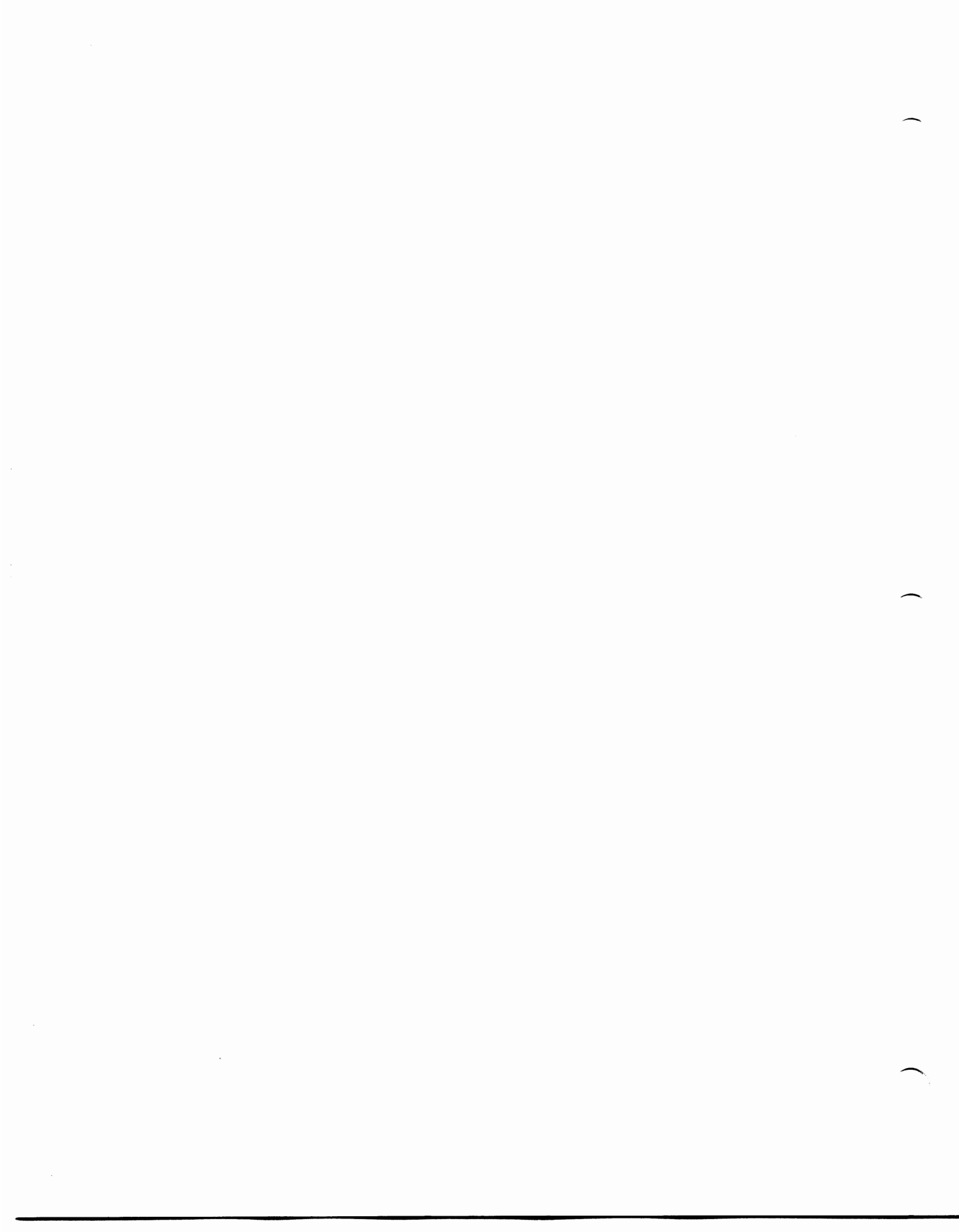

GREENBOOK COMMITTEE MEMBERS MAY - 2001

DISTRICT 1

J.M. Peterson
District Design Engineer
FDOT - District 1
801 North Broadway Street
Bartow, Florida 33830-1249
(941) 519-2241 FAX (941) 534-0915
mike.peterson@dot.state.fl.us

Dennis Daughters
City Engineer
City of Sarasota
Post Office Box 1058
Sarasota, Florida 34230
(941) 954-4180 FAX (941) 954-4174
dennis_daughters@ci.sarasota.fl.us

Ramone D. Gavarrete
County Engineer
Highlands County
505 South Commerce Avenue
Sebring, Florida 33870
(863) 402-6877 FAX (863) 402-6548
rgavarre@bcc.co.highlands.fl.us

Forrest Banks
President
Johnson Engineering, Inc.
2158 Johnson Street
Fort Myers, Florida 33901
(941) 334-0046 FAX (941) 334-3661
fhb@johnsoneng.com

DISTRICT 2

Robert D. Pearce
District Design Engineer
FDOT - District 2
Post Office Box 1089
Lake City, Florida 32056-1089
(386) 961-7885 FAX (386) 961-7809
robert.pearce@dot.state.fl.us

Donald Ditzenberger
Consulting Engineer
3701 Colony Cove Trail
Jacksonville, Florida 32277
(904) 743-6946

William Lecher
Alachua County Public Works
Department
Post Office Box 1188
Gainesville, Florida 32602-1188
(352) 374-5247 FAX (352) 337-6243
wlecher@co.alachua.fl.us

Fred Kyle
Chief, Traffic Engineering Division
City of Jacksonville
1007 Superior Street
Jacksonville, Florida 32254
(904) 387-8953 FAX (904) 387-8894
Kyle@COJ.net

DISTRICT 3

Larry Kelley
District Design Engineer
FDOT - District 3
Post Office Box 607
Chipley, Florida 32428
(850) 638-0250 FAX (850) 638-6148
larry.kelley@dot.state.fl.us

Rick Hall
Hall Planning and Engineering, Inc.
1237 North Adams Street
Tallahassee, Florida 32303
(850) 222-2277 FAX (850) 222-6555
rickhall@hpe-inc.com

Chuck Meister
City Engineer
City of Destin
4200 Two Trees Road
Destin, Florida 32541
(850) 837-4242 FAX (850) 837-3267
cmeister@cityofdestin.com

Roger Blaylock
County Engineer
Santa Rosa County
6065 Old Bagdad Highway
Milton, Florida 32583
(850) 983-2446 FAX (850) 983-2162
rogerb@co.santa-rosa.fl.us

DISTRICT 4

Gerry O'Reilly
District Design Engineer
FDOT - District 4
3400 West Commercial Blvd
Ft. Lauderdale, Florida 33309
(954) 777-4411 FAX (954) 777-4482
gerry.oreilly@dot.state.fl.us

Tanzer Kalayci
President
Keith & Schnars
6500 North Andrews Avenue
Fort Lauderdale, Florida 33309
(800) 488-1255 FAX (954) 771-3636
Tkalayci@KeithandSchnars.com

James W. Davis
Public Works Director
Indian River County
1840 25th Street
Vero Beach, Florida 32960
(561) 567-8000 FAX (561) 778-9391
jimdavis@bcc.co.indian-river.fl.us

Henry P. Cook
Director
Broward County Engineering Division
115 South Andrews Avenue, Rm 321
Fort Lauderdale, Florida 33301
(954) 357-6267 FAX (954) 357-6983
hcook@co.broward.fl.us

DISTRICT 5

Noranne B. Downs
District Design Engineer
FDOT - District 5
719 South Woodland Boulevard
Deland, Florida 32720
(904) 943-5543
noranne.downs@dot.state.fl.us

Robert T. Shutts
President
Laurel Homes
Post Office Box 300789
Fern Park, Florida 32730-0789
(407) 831-2211 FAX (407) 339-0101

Jim E. Harrison
Manager, Public Works Engineering Div.
Orange County Public Works Dept.,
Engineering
4200 S. John Young Parkway
Orlando, Florida 32839-9205
(407) 836-7908 FAX (407) 836-8024
jim.harrison@co.orange.fl.us

James R. Sloane
Deputy Director of Public Works/City
Engineer
City of Daytona Beach
Post Office Box 2451
Daytona Beach, Florida 32115-2451
(386) 671-8610 FAX (386) 671-8695
JRSloane@AOL.COM

DISTRICT 6

Felix Blanco
District Design Engineer
FDOT - District 6
1000 NW 111th Avenue
Miami, Florida 33172
(305) 472-5250
felix.blanco@dot.state.fl.us

Eugene N. Bechamps
President
E. N. Bechamps & Associates, Inc.
5200 Blue Lagoon Drive, Suite 150
Miami, Florida 33126-2050
(305) 266-7062 FAX (305) 266-6402
bechamps@bellsouth.net

Gaspar Miranda
Miami-Dade Public Works Department
111 N.W. 1st Street, Suite 1510
Miami, Florida 33128
(305) 375-2130 FAX (305) 375-2548
GXM@co.miami-dade.fl.us

Elyrosa Estevez
City of Miami Public Works Department
444 S.W. 2nd Avenue, 8th Floor
Miami, Florida 33130
(305) 416-1217 FAX (305) 416-2153
eestevez@ci.miami.fl.us

DISTRICT 7

D. Dwayne Kile
District Design Engineer
FDOT - District 7
11201 N. McKinley Drive
Tampa, Florida 33612
(813) 975-6030 FAX (813) 975-6150
dwayne.kile@dot.state.fl.us

Jim Burnside
City of Tampa
306 East Jackson Street
Tampa, Florida 33602
(813) 274-8054 FAX (813) 274-8901
jim.burnside@ci.tampa.fl.us

Charles Mixson
County Engineer
Hernando County
20 North Main Street
Brooksville, Florida 34601
(352) 754-4060 FAX (352) 754-4423
charlesm@co.hernando.fl.us

Richard Diaz Jr.
BL Companies
2005 Pan Am Circle, Suite 200
Tampa, Florida 33607
(813) 870-0007 FAX (813) 870-2210
rdiaz@blcom.com

ASSOCIATE MEMBERS

Brian Blanchard: Chairperson
State Roadway Design Engineer
FDOT - Central Office
605 Suwannee St., MS 32
Tallahassee, Florida 32399-0450
(850) 414-4377 FAX (850) 922-9293
brian.blanchard@dot.state.fl.us

Billy Hattaway
Director Office of Design
FDOT - Central Office
605 Suwannee St., MS 38
Tallahassee, Florida 32399-0450
(850) 414-4312
billy.hattaway@dot.state.fl.us

Joy Puerta
City Bicycle/Pedestrian Coordinator
City of Boca Raton, Municipal Services
Dept.
201 West Palmetto Park Road
Boca Raton, Florida 33432
(561) 416-3410 FAX (561) 416-3418
jpuerta@ci.boca-raton.fl.us

Theo Petritsch
State Pedestrian/Bicycle Coordinator
FDOT - Central Office
605 Suwannee St., MS 82
Tallahassee, Florida 32399-0450
(850) 487-1200 FAX (850) 922-2935
theo.petritsch@dot.state.fl.us

Robert F. Quigley
Roadway Design Engineer
FDOT - Central Office
605 Suwannee St., MS 32
Tallahassee, Florida 32399-0450
(850) 414-4356 FAX (850) 922-9293
robert.quigley@dot.state.fl.us

Ed Rice
State Safety Engineer
FDOT - Central Office
605 Suwannee St., MS 53
Tallahassee, Florida 32399-0450
(850) 488-3546 FAX (850) 922-2935
ed.rice@dot.state.fl.us

Harry Reed
D-7 Public Transportation Manager
FDOT - District 7
11201 N. McKinley Drive, MS 7-330
Tampa, Florida 33612
(813) 975-6408 FAX (813) 975-6443
harry.reed@dot.state.fl.us

Joseph Santos
FDOT - Central Office
605 Suwannee Street, MS 19
Tallahassee, Florida 32399-0450
(850) 414-4909 FAX (850) 921-6361
joseph.santos@dot.state.fl.us

James A. Mills
Criteria & Standards Section Leader
FDOT - Central Office
605 Suwannee St., MS 32
Tallahassee, Florida 32399-0450
(850) 414-4318 FAX (850) 922-9293
jim.mills@dot.state.fl.us

David F. Kuhlman
Florida Power & Light, Inc.
Post Office Box 029100
Miami, Florida 33102-9100
(305) 552-2995 FAX (305) 228-5695
david.f.kuhlman@fpl.com

Melanie Weaver Carr
Senior Policy Analyst
FDOT - Central Office
605 Suwannee St., MS 28
Tallahassee, Florida 32399-0450
(850) 414-4817 FAX (850) 488-3567
melanie.carr@dot.state.fl.us

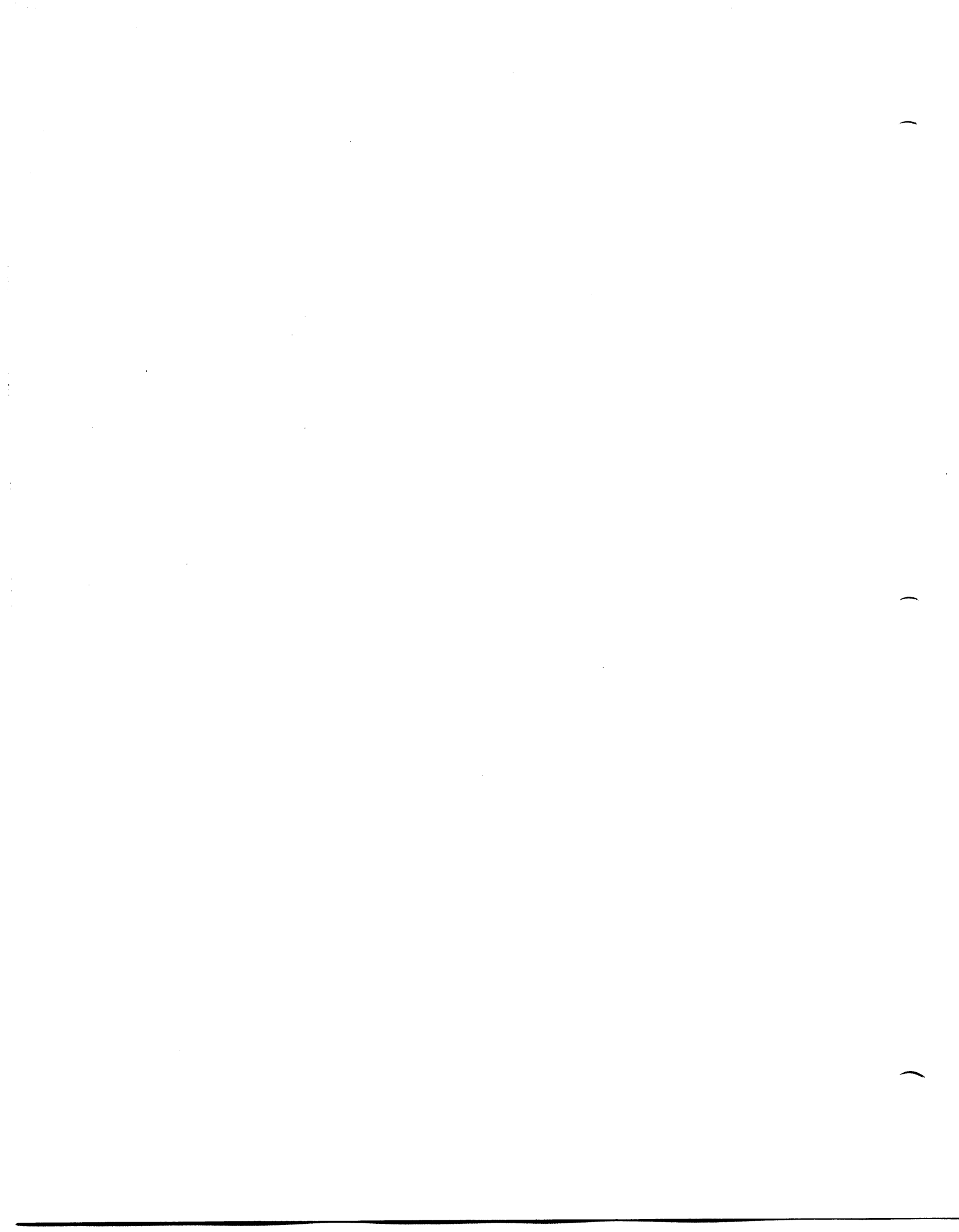

TABLE OF CONTENTS

INTRODUCTION	i
POLICY & OBJECTIVES	iii
DEFINITION OF TERMS	v

CHAPTER 1 PLANNING

A.	INTRODUCTION	1
B.	CONFLICTING CRITERIA	2
	B.1 Economic Constraints	2
	B.2 Access	2
	B.3 Maintenance Capabilities	3
	B.4 Utility and Transit Operations	3
	B.5 Emergency Response for Fire, Police, etc.	3
	B.6 Environmental Impact	3
	B.7 Community and Social Impact	4
	B.8 Modes of Transportation	4
C.	HIGHWAY FUNCTION AND CLASSIFICATION	4
	C.1 Function	4
	C.1.a. Volume	5
	C.1.b. Highway User Types	5
	C.1.c. Trip Characteristics	5
	C.1.d. Speed	5
	C.1.e. Safety	5
	C.1.f. Level of Service	5
	C.1.g. Access Requirements	6
	C.1.h. Public Transit Use	6
	C.2 Classification	6

C.2.a. Basic Classification	6
C.2.a.1 Local	6
C.2.a.2 Collector	6
C.2.a.3 Arterial	7
C.2.b. Classification Modifications	7
C.2.b.1 Urban	7
C.2.b.2 Major/Minor	7
D. OPERATION	7
D.1 Policy	8
D.2 Objectives	8
D.3 Activities	8
D.3.a. Maintenance and Reconstruction	8
D.3.b. Work Site Safety	9
D.3.c. Traffic Control	9
D.3.d. Emergency Response	9
D.3.e. Coordination and Supervision	9
D.3.f. Inspection and Evaluation	10

CHAPTER 2 LAND DEVELOPMENT

A. INTRODUCTION	1
B. OBJECTIVES	2
C. PRINCIPLES AND GUIDELINES	2
C.1 Network Design	3
C.2 Access Control	4
C.3 Land Use Controls and Space Allocation	5
D. CONFLICT AND COORDINATION	6
E. CONTROL TECHNIQUES	7
E.1 Right of Way Acquisition	7
E.2 Police Power	7
E.2.a General Regulatory Requirements	7

E.2.b	Specific Control	8
E.3	Contracts and Agreements	8
E.4	Education	8

CHAPTER 3 GEOMETRIC DESIGN

A.	INTRODUCTION	1
B.	OBJECTIVES	3
C.	DESIGN ELEMENTS	3
C.1.	Design Speed	3
C.2.	Design Vehicles	5
C.3.	Sight Distance	6
C.3.a.	Stopping Sight Distance	6
C.3.b.	Passing Sight Distance	7
C.3.c.	Sight Distance at Decision Points	8
C.3.d.	Intersection Sight Distance	8
C.4.	Horizontal Alignment	9
C.4.a.	General Criteria	9
C.4.b.	Superelevation	10
C.4.c.	Curvature	11
C.4.d.	Superelevation Transition (superelevation runoffs plus tangent runoff)	11
C.4.e.	Lane Widening on Curves	12
C.5.	Vertical Alignment	12
C.5.a.	General Criteria	12
C.5.b.	Grades	12
C.5.c.	Vertical Curves	13
C.6.	Alignment Coordination	13
C.7.	Cross Section Elements	14
C.7.a.	Number of Lanes	15
C.7.b.	Pavement	15
C.7.b.1.	Pavement Width	15
C.7.b.2.	Pavement Cross Slope (not in superelevation)	15
C.7.c.	Shoulders	15
C.7.c.1.	Shoulder Width	16
C.7.c.2.	Shoulder Cross Slope	16

C.7.d.	Sidewalks	17
C.7.e.	Medians	18
C.7.e.1.	Type of Median	19
C.7.e.2.	Median Width	19
C.7.e.3.	Median Slopes	20
C.7.e.4.	Median Barriers	21
C.7.f.	Roadside Clear Zone	21
C.7.f.1.	Roadside Clear Zone Width	22
C.7.f.2.	Roadside Slopes	22
C.7.f.3.	Criteria for Guardrail	23
C.7.g.	Curbs	23
C.7.h.	Parking	23
C.7.i.	Right of Way	24
C.7.j.	Changes in Typical Section	25
C.7.j.1.	General Criteria	25
C.7.j.2.	Lane Deletions and Additions	25
C.7.j.3.	Special Use Lanes	25
C.7.j.4.	Structures	26
C.7.j.4.(a).	Horizontal Clearance	26
C.7.j.4.(b).	Vertical Clearance	26
C.7.j.4.(c).	End Treatment	27
C.8.	Access Control	27
C.8.a.	Justification	27
C.8.b.	General Criteria	27
C.8.b.1.	Location of Access Points	27
C.8.b.2.	Spacing of Access Points	28
C.8.b.3.	Restrictions of Maneuvers	28
C.8.b.4.	Turn Lanes	28
C.8.b.5.	Grade Separation	29
C.8.b.6.	Roundabouts (Small Circular Islands)	29
C.8.c.	Control for All Limited Access Highways	30
C.8.d.	Control of Urban Streets	30
C.8.e.	Control for Rural Highways	31
C.8.f.	Land Development	31
C.9.	Intersection Design	31
C.9.a.	General Criteria	32
C.9.b.	Sight Distance	33
C.9.b.1.	General Criteria	33
C.9.b.2.	Obstructions to Sight Distance	34
C.9.b.3.	Stopping Sight Distance	35

C.9.b.3.(a). Approach to Stops	35
C.9.b.3.(b). On Turning Roads	35
C.9.b.4. Sight Distance for Intersection Maneuvers (Non-signalized)	36
C.9.b.4.(a). Crossing Maneuver	36
C.9.b.4.(b). Left Turn Crossings	37
C.9.c. Auxiliary Lanes	37
C.9.c.1. Merging Maneuvers	38
C.9.c.2. Acceleration Lanes	38
C.9.c.3. Exit Lanes	39
C.9.d. Turning Roadways	40
C.9.d.1. Design Speed	40
C.9.d.2. Horizontal Alignment	40
C.9.d.3. Vertical Alignment	41
C.9.d.4. Cross Section Elements	41
C.9.e. At Grade Intersections	42
C.9.e.1. Turning Radii	42
C.9.e.2. Cross Section Correlation	42
C.9.e.3. Median Openings	43
C.9.e.4. Channelization	43
C.9.f. Driveways	44
C.9.g. Interchanges	44
C.9.h. Clear Zone	45
C.10. Other Design Factors	46
C.10.a. Pedestrian Facilities	46
C.10.a.1. Policy and Objectives - New Facilities	46
C.10.a.2. Accessibility Requirements	46
C.10.a.3. Sidewalks	46
C.10.a.4. Curb Ramps	47
C.10.a.5. Additional Considerations	48
C.10.b. Bicycle Facilities	48
C.10.c. Bridge Design Loadings	48
C.10.d. Dead End Streets and Cul-de-sacs	49
C.10.e. Bus Benches and Transit Shelters	49
C.10.f. Traffic Calming	49
C.11. Reconstruction	50
C.11.a. Introduction	50
C.11.b. Evaluation of Streets and Highways	50
C.11.c. Priorities	50
C.12. Design Exceptions	52

CHAPTER 4 ROADSIDE DESIGN

A.	INTRODUCTION	1
B.	POLICY	1
C.	OBJECTIVES	1
D.	ROADSIDE DESIGN	2
D.1	Geometric Changes	2
D.1.a.	Horizontal Curves	2
D.1.b.	Vertical Curves	2
D.1.c.	Changes in Cross Section	3
D.1.d.	Decision or Conflict Points	3
D.2	Fills	3
D.3	Cuts	3
D.4	Roadside Canals	3
D.5	Vegetation	4
D.5.a.	Stability	4
D.5.b.	Drainage	4
D.5.c.	Crash Cushions	4
D.5.d.	Environmental and Aesthetic Considerations	4
D.5.e.	Landscaping - Design Considerations	4
D.6	Drainage	5
D.6.a.	Inlets	5
D.6.b.	Ditches	5
D.6.c.	Culverts	5
D.7	Curbs	6
D.8	Poles and Support Structures	6
D.9	Intersections	7
D.10	Underpasses	7
D.11	Bridges and Overpasses	7
D.12	Mailboxes	8
D.13	Bus Shelters	8
E.	PROTECTIVE DEVICES	8
E.1	Redirection Devices	8
E.1.a.	Function	8
E.1.b.	Warranting Conditions	8
E.1.c.	Location	9
E.1.d.	Length	9

E.1.e	Vehicle Containment	9
E.1.f	Barrier Types	9
E.1.g	Transitions	10
E.1.h	Terminations	10
E.2	Energy Absorbing Devices	10
E.2.a	Function	10
E.2.b	Warranting Conditions	11
E.2.c	Design Criteria	11
E.2.d	Design Details	11

CHAPTER 5 PAVEMENT DESIGN, CONSTRUCTION AND MAINTENANCE

A.	INTRODUCTION	1
B.	PAVEMENT DESIGN	1
B.1.	Pavement Type Selection	1
B.2.	Structural Design	2
B.3.	Skid Resistance	2
B.4.	Drainage	2
B.5.	Shoulder Treatment	3
C.	PAVEMENT CONSTRUCTION	3
D.	PAVEMENT MAINTENANCE	4

CHAPTER 6 ROADWAY LIGHTING

A.	INTRODUCTION	1
B.	OBJECTIVES	1
C.	WARRANTING CONDITIONS	2
C.1.	Criteria Based Upon Accident History	2
C.2.	Criteria Based Upon Analysis and Investigation	3

C.3. General Criteria	3
D. LEVEL OF ILLUMINATION	4
E. UNIFORMITY OF ILLUMINATION	4
F. UNDERPASSES	5
F.1. Daytime Lighting	5
F.2. Night Lighting	5
G. MAINTENANCE	5
H. LIGHT POLES	5

CHAPTER 7

RAIL-HIGHWAY GRADE CROSSINGS

A. INTRODUCTION	1
B. OBJECTIVE AND PRIORITIES	1
B.1. Conflict Elimination	1
B.2. Hazard Reduction	1
C. DESIGN OF RAIL-HIGHWAY GRADE CROSSINGS	2
C.1. Sight Distance	2
C.1.a Stopping Sight Distance	2
C.1.b. Sight Triangle	2
C.1.c. Crossing Maneuvers	3
C.2 Approach Alignment	3
C.2.a. Horizontal Alignment	3
C.2.b. Vertical Alignment	4
C.3 Highway Cross Section	4
C.3.a. Pavement	4
C.3.b. Shoulders	5
C.3.c. Medians	5
C.3.d. Roadside Clear Zone	5
C.3.e. Auxiliary Lanes	5
C.4. Roadway Design	6
C.5. Access Control	6

C.6.	Parking	6
C.7.	Traffic Control Devices	6
C.8.	Rail-Highway Grade Crossing Surface	7
C.9.	Roadway Lighting	7
C.10.	Crossing Configuration	7
D.	MAINTENANCE AND RECONSTRUCTION	7

CHAPTER 8 PEDESTRIAN TRAFFIC

A.	INTRODUCTION	1
B.	MINIMIZING CONFLICTS	1
B.1.	General Needs	2
B.2.	Independent Systems	2
B.3.	Horizontal Separation	2
B.3.a.	General Criteria	2
C.	BARRIER SEPARATION	3
C.1.	Longitudinal Barriers	3
C.2.	Fencing or Landscaping	3
D.	VERTICAL SEPARATION	4
D.1.	Overpasses	4
D.2.	Underpasses	4
E.	PROTECTION	4
E.1.	Crossings	5
E.2.	Controls	5
E.3.	Sight Distance	5
E.4.	Lighting	6

CHAPTER 9 BICYCLE FACILITIES

A.	INTRODUCTION	1
B.	ON-STREET FACILITIES	1
	B.1. Paved Shoulders	1
	B.2. Bike Lanes	2
	B.3. Curb Lanes	3
C.	SHARED USE PATHS	3
	C.1. Separation Between Share Use Paths and Roadways	4
	C.2. Width	5
	C.3. Horizontal Clearance	6
	C.4. Vertical Clearance	6
	C.5. Design Speed	6
	C.6. Structures	6

CHAPTER 10 MAINTENANCE

A.	INTRODUCTION	1
B.	OBJECTIVES	1
C.	POLICY	1
D.	IDENTIFICATION OF NEEDS	2
	D.1. Inspection	2
	D.2. Accident Records	2
E.	ESTABLISHMENT OF PRIORITIES	3
F.	ESTABLISHMENT OF PROCEDURES	3
	F.1. Emergency Maintenance	3
	F.2. Routine Maintenance	4
	F.3. Special Maintenance	5

CHAPTER 11 WORK SITE SAFETY

A.	INTRODUCTION	1
B.	OBJECTIVES	1
C.	POLICY	2
D.	PLANNING OF OPERATIONS	2
D.1.	Project Requirements	2
D.1.a.	Type of Operation	2
D.1.a.1.	Routine Operations	2
D.1.a.2.	Emergency Operations	2
D.1.a.3.	Special Operations	3
D.1.b.	Nature of Work	3
D.1.c.	Nature of Work Site	4
D.2.	Work Scheduling	4
D.3.	Traffic Control and Protection	4
D.4.	Coordination with Other Agencies	5
E.	WORK SITE OPERATIONS	6
E.1.	Public Information	6
E.2.	Contracts and Permits	6
E.3.	Inspection and Supervision	6
F.	EVALUATION OF PROGRAM	6

CHAPTER 12 CONSTRUCTION

A..	INTRODUCTION	1
B.	OBJECTIVES	1
C.	CONTROL OF THE WORK	2

C.1.	Plans and Contract Documents	2
C.1.a.	Plans	2
C.1.b.	Alterations in Plans	2
C.1.c.	Working Drawings (for Structures)	2
C.1.c.1.	General	2
C.1.c.2.	Submission of Working, Shop and Erection Drawings	2
C.1.c.3.	Responsibility for Accuracy of Working Drawings	3
C.2.	Coordination of Plans, Specifications and Special Provisions	3
C.3.	Conformity of Work with Plans	3
C.4.	Conformity of Work Shown in Regulatory Permits	4
C.5.	Authority of the Engineer	4
C.6.	Engineering and Layout	4
C.6.a.	Control Points Furnished	4
C.6.b.	Layout of Work	4
C.6.c.	Personnel, Equipment and Record Requirements	5
C.7.	Contractor's Supervision	5
C.7.a.	Prosecution of Work	5
C.7.b.	Contractor's Superintendent	5
C.7.c.	Supervision for Emergencies	6
C.8.	General Inspection Requirements	6
C.8.a.	Cooperation by Contractor	6
C.8.b.	Failure of Engineer to Reject Work During Construction	6
C.9.	Final Construction Inspection Maintenance until Final Acceptance	6
D.	CONTROL OF MATERIALS	7
D.1	Source of Supply and Quality Requirements	7
D.1.a.	Only Approved Materials to be Used	7
D.2.	Inspection and Tests at Source of Supply	7
D.2.a.	General	7
D.2.b.	Cooperation by Contractor	7
D.3.	Control by Samples and Tests	7
D.3.a.	Materials to be Tested, Samples	7
D.3.b.	Applicable Standards	7
D.4.	Quality Control System	8
D.4.a.	General Requirements	8
D.4.b.	Documentation	8
D.4.c.	Corrective Actions	8

CHAPTER 13 PUBLIC TRANSIT

A.	INTRODUCTION	1
B.	OBJECTIVE	2
C.	TRANSIT COMPONENTS	2
C.1.	Stops and Station Areas	2
C.2.	Shelters	2
C.3.	Benches	3
C.4.	Concrete Bus Pads	3
C.5.	Bus Bays (Pullout or Turnout Bays)	3

CHAPTER 14 DESIGN EXCEPTIONS

A.	GENERAL	1
B.	DESIGN EXCEPTIONS	1
C.	RECOMMENDATIONS FOR AND APPROVAL OF DESIGN EXCEPTIONS ..	2
D.	COORDINATION OF DESIGN EXCEPTIONS	2
E.	JUSTIFICATION AND DOCUMENTATION OF DESIGN EXCEPTIONS	3
F.	FINAL PROCESSING OF DESIGN EXCEPTIONS	4
	EXHIBIT 14 - A	5

TABLES

Table 3-1	Recommended Minimum Design Speed (MPH)	53
Table 3-2	Design Vehicles	54
Table 3-3	Horizontal Curvature	55
Table 3-4	Recommended Maximum Grades in Percent	56
Table 3-5	Maximum Change in Grade Without Using Vertical Curve	56
Table 3-6	Sight Distance and Lengths of Vertical Curves	57

Table 3-7	Minimum Lane Widths	58
Table 3-8	Minimum Widths of Pavement and Shoulders and Two(2) Lane Rural Highways	58
Table 3-9	Shoulder Widths For Multilane Rural Divided Highways	58
Table 3-10	Median Width For Freeways (Urban and Rural)	59
Table 3-11	Median Width (FEET) For Rural Highways (Multilane Facilities) and Urban Streets	59
Table 3-12	Minimum Width of Clear Zone	60
Table 3-13	Access Control For All Limited Access Highways	61
Table 3-14	Sight Distance For Approach To Stops	61
Table 3-15	Length of Taper For Use in Conditions With Full Width Speed Change Lanes	61
Table 3-16	Design Lengths of Speed Change Lanes Flat Grades- 2 Percent or Less	62
Table 3-17	Ratio of Length of Speed Change Lane on Grade to Length on Level	63
Table 3-18	Minimum Deceleration Lengths for Exit Terminals	64
Table 3-19	Minimum Acceleration Lengths for Entrance Terminals	65
Table 3-20	Calculated and Design Values for Pavement Widening on Open Highway Curves	66
Table 3-21	Design Widths of Pavements for Turning Roadways	67
Table 3-22	Superelevation Rates for Curves at Intersection	68
Table 3-23	Maximum Rate of Change in Pavement Edge Elevation for Curves at Intersections	69
Table 3-24	Maximum Algebraic Difference in Pavement Cross Slope at Turning Roadway Terminals	69
Table 7-1	Sight Distance At Railroad Grade Crossings	8

FIGURES

Figure 3-1	Rural Highways, Urban Freeways and High Speed Urban Arterials	70
Figure 3-2	Urban Highways and Streets	71
Figure 3-2A	Sight Distance on Curves	72
Figure 3-3	Critical Length Versus Upgrade	73
Figure 3-4	Length of Crest Vertical Curve(Stopping Sight Distance)	74
Figure 3-5	Length of Crest Vertical Curve (Passing Sight Distance)	75
Figure 3-6	Length of Sag Vertical Curve	76
Figure 3-7	Sight Distances for Approach to Stop on Grades	77

Figure 3-8	Sight Distance for Crossing Maneuver (Affect of Grade Not Included) P- Class Vehicles	78
Figure 3-9	Sight Distance for Crossing Maneuver (Affect of Grade Not Included) SU & Bus- Class Vehicles	79
Figure 3-10	Sight Distance for Crossing Maneuver (Affect of Grade Not included)	80
Figure 3-11	Intersection Sight Distance	81
Figure 3-12	Sight Distance at Intersections	82
Figure 3-13	Termination of Merging Lanes	83
Figure 3-14	Entrance for Deceleration Lane	84
Figure 3-15	Typical Storage Lane	85
Figure 3-16	Standard HS-20 Trucks	86
Figure 3-17	Lane Loading	87
Figure 7-1	Visibility Triangle at Railroad Crossings	9
Figure 7-2	Grade Crossing Configuration	10
Figure 9-1	Minimum Widths for Bike Lanes	7
Figure 9-2	Major Intersection With Separate Right Turn Lane Urban Typical Section (Curb and Gutter)	8
Figure 9-3	Major Intersection No Right Turn Lane Plus Busbay Urban Typical Section (Curb and Gutter)	9
Figure 9-4	Major with Local Street Intersection No Right Turn Lane Urban Typical Section (Curb and Gutter)	10
Figure 9-5	Major Lane with Local Street Intersection No Right Turn Lane On Street Parking Urban Typical Section (Curb and Gutter)	11
Figure 9-6	Major Intersection with Designated Shoulder Separate Right Turn Lane Rural Typical Section (Paved Shoulder)	12
Figure 9-7	Major with Local Street Intersection Designated Shoulder No Right Turn Lane Rural Typical Section (Paved Shoulder)	13
Figure 9-8	Major Intersection Separate Right Turn Lane 3' or 4' Undesignated Bike Lane Urban Typical Section (Curb and Gutter)	14
Figure 9-9	Major Intersection Right Turn Drop Lane Designated Or Undesignated Bike Lane Urban Typical Section (Curb and Gutter)	15
Figure 9-10	"Tee" Intersection Separate Right Turn Lane Urban Typical Section (Curb and Gutter)	16
Figure 9-11	"Tee" Intersection Right Turn Drop Lane Urban Typical Section (Curb and Gutter)	17
Figure 9-12	Detail of Designated Bike Lane and Bike Shoulder Markings	18



INTRODUCTION

The purpose of this Manual is to provide uniform minimum standards and criteria for the design, construction, and maintenance of all public streets, roads, highways, bridges, sidewalks, curbs and curb ramps, crosswalks (where feasible), bicycle facilities, underpasses, and overpasses used by the public for vehicular and pedestrian traffic as directed by Sections 334.044(10)(a) and 336.045, Florida Statutes.

In the following statutory excerpts, the term “Department” is referring to the Florida Department of Transportation (FDOT).

Section 334.044, Florida Statutes. Department; powers and duties. The department shall have the following general powers and duties:

(10)(a) To develop and adopt uniform minimum standards and criteria for the design, construction, maintenance, and operation of public roads pursuant to the provisions of Section, 336.045, Florida Statutes.

Section 336.045, Florida Statutes. Uniform minimum standards for design, construction, and maintenance; advisory committees.

(1) The department shall develop and adopt uniform minimum standards and criteria for the design, construction, and maintenance of all public streets, roads, highways, bridges, sidewalks, curbs and curb ramps, crosswalks, where feasible, bicycle ways, underpasses and overpasses used by the public for vehicular and pedestrian traffic. In developing such standards and criteria, the department shall consider design approaches which provide for the compatibility of such facilities with the surrounding natural or manmade environment; the safety and security of public spaces; and the appropriate aesthetics based upon scale, color, architectural style, materials used to construct the facilities, and the landscape design and landscape materials around the facilities....

(4) All design and construction plans for projects that are to become part of the county road system and are required to conform with the design and construction standards established pursuant to subsection (1) must be certified to be in substantial conformance with the standards established pursuant to subsection (1) that are then in effect by a professional engineer who is registered in this state.

These standards are intended to provide basic guidance for developing and maintaining a highway system with reasonable operating characteristics and a minimum number of hazards.

Standards established by this Manual are intended for use on all new construction projects off the state highway and federal aid systems. It is understood that the standards herein cannot be applied completely to all reconstruction and maintenance type projects. However, the standards shall be applied to the extent that economic and environmental considerations and existing development will allow.

When this Manual refers to guidelines and design standards given by current American Association of State Highway and Transportation Officials (AASHTO) publications, these guidelines and standards shall generally be considered as minimum criteria. The Department may have standards and criteria which differ from the minimum presented in this Manual or by AASHTO for streets and highways under its jurisdiction. A county or municipality may substitute standards and criteria adopted by the Department for some or all portions of design, construction, and maintenance of their facilities. Department standards, criteria, and manuals must be used when preparing projects on the state highway system or the national highway system.

Criteria and standards set forth in other manuals which have been incorporated by reference shall be considered as requirements within the authority of this Manual.

The contents of this Manual are reviewed annually by the Florida "GreenBook" Advisory Committee. Membership of this committee is established by the above referenced Section 336.045(2), Florida Statutes. Revisions or additions to the Manual will be distributed to all registered Manual holders and dated in the bottom right-hand corner of the page. The Committee responsible for specific revisions has corresponding membership dates. Comments, suggestions, or questions may be directed to any committee member.

POLICY

Specific policies governing the activities of planning, design, construction, reconstruction, maintenance or operation of streets and highways are listed throughout this Manual. All agencies and individuals involved in these activities shall be governed by the following general policies:

- Each public street and highway, and all activates thereon, shall be assigned to the jurisdiction of some highway agency. Each highway agency should establish and maintain a program to promote safety in all activities on streets and highways under its jurisdiction.
- Highway safety shall be considered and given a high priority in order to promote the achievement of the maximum safety benefits for given expenditures and efforts.
- The provision for safe, high-quality streets and highways, and maximum transit opportunities should take priority over the provision for the maximum highway mileage obtainable for the available funds.

OBJECTIVES

The planning, design, construction, reconstruction, maintenance and operation of streets and highways should be predicated upon meeting the following objectives:

- Develop and maintain a highway system that provides the safest practicable environment for motorists, cyclists, pedestrians and workmen.
- Establish and maintain procedures for construction, maintenance, utility and emergency operations that provide for safe highway and transit operating conditions during these activities.
- Provide streets and highways with operating characteristics that allow for reasonable limitations upon the capabilities of vehicles, drivers, cyclists, pedestrians and workers.
- Provide uniformity and consistency in the design and operation of streets and highways.
- Provide for satisfactory resolution of conflicts between the surface transportation system and social and environmental considerations to aid neighborhood integrity.

- Reconstruct or modify existing facilities to reduce the hazard to the highway users.
- Reduce the deaths, injuries and damage due to highway crashes.

Additional general and specific objectives related to various topics and activities are listed throughout this Manual. Where specific standards or recommendations are not available or applicable, the related objectives shall be utilized as general guidelines.

DEFINITION OF TERMS

The following terms shall, for the purpose of this Manual, have the meanings respectively ascribed to them, except instances where the context clearly indicates a different meaning.

ADT - Average daily two-way volume of traffic.

AVERAGE RUNNING SPEED - For all traffic, or component thereof, the summation of distances divided by the summation of running times.

BICYCLE LANE (BIKE LANE) - A portion of a roadway (typically 4-5 ft) which has been designated by signing and pavement markings for the preferential or exclusive use by bicyclist.

BIKEWAY - Any road, path, or other facility which in some manner is specifically designated as being open to bicycle travel, regardless of whether such facilities use of bicycles are to be shared with other transportation modes.

CLEAR ZONE - The total roadside border area starting at the edge of the motor vehicle travel lane, available for safe use by errant vehicles. This area may consist of a shoulder, a recoverable slope, a non-recoverable slope, and/or a clear runout area. The desired width is dependent upon the traffic

volumes and speeds, and on the roadside geometry. Note: The aforementioned "border area" is not the same as "border width". Also, see Horizontal Clearance.

DHV

- Design hourly two-way volume of traffic.

DESIGN SPEED

- A speed determined for design and correlation of the physical features of a highway that influence vehicle operation. It is the maximum safe speed that can be maintained over a specific section of highway when conditions are so favorable that the design features of the highway govern.

EXPRESSWAY

- A divided arterial highway for through traffic with full or partial control of access and generally with grade separations at major intersections.

FREEWAY

- An expressway with full control of access.

FRONTAGE ROAD

- A street or highway constructed adjacent to a higher classification street or other roadway network for the purpose of serving adjacent property or control access.

- GRADE SEPARATION** - A crossing of two roadways or a roadway and a railroad or pedestrian pathway at different levels.
- HIGH SPEED** - Speeds of 50 mph or greater.
- HIGHWAY, STREET, OR ROAD** - A general term, denoting a public way for purposes of traffic, both vehicular and pedestrian, including the entire area within the right of way. The term street is generally used for urban or suburban areas.
- HORIZONTAL CLEARANCE** - Lateral distance from edge of motor vehicle travel lane to a roadside object or feature.
- INTERSECTION** - The general area where two or more streets or highways join or cross.
- MAY** - A permissive condition. Where "may" is used, it is considered to denote permissive usage.
- NEW CONSTRUCTION** - The construction of any public road facility (paved or unpaved) where none previously existed, or the act of paving any previously unpaved road, except as provided in Section 3 - A of these standards.

OPERATING SPEED

- The highest overall speed at which a driver can travel on a given highway under favorable weather conditions and under prevailing traffic conditions without at any time exceeding the safe speed as determined by the design speed on a section by section basis.

PASSENGER PAD

- As defined in Section 10.2.1 of the Federal Register, Volume 56, No.173, as part of the Americans With Disabilities Act of 1991 (ADA); a firm stable surface with a minimum clear length of 96 inches (measured from the curb or vehicle roadway edge) and minimum clear width of 60 inches (measured parallel to the vehicle roadway) to the maximum extent allowed by legal or site constraints; and shall be connected to streets, sidewalks or pedestrian paths by an accessible route.

RECONSTRUCTION

- Any road construction other than new construction.

RECOVERY AREA

- Generally synonymous with clear zone.

RESIDENTIAL STREETS

- Streets primarily serving residential access to the commercial, social, and recreational needs of the community. These are generally lower volume and lower speed

- facilities than the primary arterial and collector routes of the local system "or as adopted by local government ordinance".
- RIGHT OF WAY** - A general term denoting land, property of or interest therein, usually in a strip, acquired for or donated for transportation purposes. More specifically, land in which the State, the Department, a county, a transit authority, or a municipality owns the fee or has an easement devoted to or required for use as a public road.
- ROADWAY** - The portion of a street or highway, including shoulders, for the intended use of vehicles.
- SHALL** - A mandatory condition. (When certain requirements are described with the "shall" stipulation, it is mandatory these requirements be met.)
- SHOULD** - An advisory condition. Where "should" is used, it is considered to denote permissive usage.
- SLOPES** - Slopes in this manual are expressed as a ratio of vertical to horizontal (V:H).
- SURFACE TRANSPORTATION** - Network of highways, streets, and/or roads. Term can be applied to local system or

SYSTEM

expanded to desired limits of influence.

TRAVELED WAY

- The portion of the roadway for the movement of vehicles exclusive of shoulders.

TURNING ROADWAY

- A connecting roadway for traffic turning between two intersection legs.

UNDESIGNATED BIKE LANE

- A bike lane which is not designated with the diamond, bike and arrow pavement markings. It is striped as a regular bike lane on approaches to intersections.

VEHICLE

- Every device upon, or by which any person or property is or may be transported or drawn upon a travel way, excepting devices used exclusively upon stationary rails or tracks.

WIDE CURB LANE

- A portion of the roadway which can be used by bicycles and motorized traffic, characterized by a curb lane, which is of such width that bicycle and motorized traffic can be accomplished in the same lane. This lane should always be the through lane closest to the curb (when a curb is provided) or the shoulder edge of the road when a curb is not provided.

CHAPTER 1

PLANNING

A. INTRODUCTION

Planning, as discussed in this section, is not to be confused with the broader transportation system's planning and project programming which normally precedes the design, construction, and maintenance of highways.

Developing and maintaining an efficient highway system requires careful planning by each unit in a highway agency. This includes both planning for the design and construction of streets and highways and planning for operating the facilities. Overall planning would include a consideration for all aspects of design, construction, and operations (including maintenance) affecting the resulting characteristics of streets and highways. These characteristics will be significantly affected by the degree to which the various demands and requirements on the highway system are satisfied in the initial planning and design.

Successful highway design requires that the role of each new facility in the overall highway system be clearly delineated. The determination and clear definition of the function and classification of each street and highway is also required. Safety and efficiency of new facilities is predicated, to a large extent, on corridor selection and provisions for adequate right of way, alignment, and access control. Initial planning and design should also consider provisions for future modifications and upgrading required by changes in speed, volume, or standards.

Plans for actually operating a new street or highway should be considered in the initial planning and should be closely coordinated with the design of the facility. Development of plans and procedures for successfully operating an existing highway system must include a consideration of all activities affecting the operating characteristics of each street and highway.

Planning, designing, operating, and maintaining a highway system has become more complex in recent years. These disciplines must now address the needs of increased public transit and pedestrian traffic, increasing bicyclist use, the growing number of elder road users, and the mobility needs of the disabled. This begins in planning and continues throughout the design and operational process.

B. CONFLICTING CRITERIA

Development of safe streets and highways for all modes of surface transportation (autos, trucks, bicycles, pedestrians, transit vehicles, etc.) should receive the highest priority in the design process. This objective may tend to be compromised by other conflicting requirements and demands upon the highway system. The following criteria should be considered and resolved in the initial planning and design of streets and highways to avoid a sacrifice of required safety characteristics.

B.1 Economic Constraints

In determining the benefit/cost ratio for any proposed facility, the economic evaluation should go beyond the actual expenditure of highway funds and the capacity and efficiency of the facility. Overall costs and benefits of various alternatives should include an evaluation of the probable environmental, community, and social impact and their effect upon highway quality and cost.

Allocation of sufficient funds for obtaining the proper corridor and adequate right of way and alignment should receive the initial priority. Future acquisition of additional right of way and major changes in alignment are often economically prohibitive. This can result in substandard streets and highways with permanent hazards. Reconstruction or modification under traffic is expensive, inconvenient, and hazardous to the highway user. This increase in costs, hazards, and inconvenience can be limited by initial development of quality facilities.

B.2 Access

Demand for access to streets and highways by adjacent property owners can produce problems. Although the public must have reasonable access to the highway network, it is necessary to have certain controls and restrictions. Allowing indiscriminate access can seriously compromise the safety capacity and level of service of a street or highway, consequently reducing its utility and general economic value.

The proper layout of the highway network and the utilization of effective land use controls (CHAPTER 2 - LAND DEVELOPMENT) can provide the basis for regulating access. The actual access controls should conform to the guidelines given in CHAPTER 3 - GEOMETRIC DESIGN.

B.3 Maintenance Capabilities

Planning and design of streets and highways should include provisions for the performance of required maintenance. The planning of the expected maintenance program should be coordinated with the initial highway design to ensure maintenance activities may be conducted without excessive traffic conflicts or hazards.

B.4 Utility and Transit Operations

Utility accommodation within rights of way is generally considered to be in the public's best interest, since rights of way frequently offer the most practical engineering, construction, and maintenance solutions for utility service to businesses and residences. Utility and transit facility locations should be carefully chosen to minimize interference with the operations and safety of the transportation facility.

B.5 Emergency Response for Fire, Police, etc.

Development of an effective emergency response program is dependent upon the nature of the highway network and the effectiveness of the operation of the system. Provisions for emergency access and communication should be considered in the initial planning and design of all streets and highways. Local emergency response personnel should be included in primary activities.

B.6 Environmental Impact

Construction and operation of streets and highways frequently produces an adverse effect upon the environment. Early consideration and solution of environmental problems can avoid costly delays and modifications that may compromise the quality and efficiency of operation. Specific problems often encountered include the following:

- Noise pollution
- Air and water pollution
- Interruption of the hydrological system

- Degradation of the biological system

B.7 Community and Social Impact

Quality and value of a community is directly influenced by the layout and design of streets and highways. Quality of the network determines the freedom and efficiency of movement. Inadequate design of the network and poor land use practices can lead to undesirable community separation and deterioration. Specific design of streets and highways has a large effect upon the overall aesthetic value which is important to the motorist and resident.

Conflicting criteria should be resolved through early coordination. It is the responsibility of the planner and designer to consider, and where possible, select alternatives alleviating conflicts and promoting positive solutions to interrelated problems.

B.8 Modes of Transportation

Planning processes should analyze/evaluate other modes of transportation and their relationship to the highway system. Recommendations for incorporation into the design process should be made. This will involve coordination with local, city, county, special interest groups, etc., in developing such recommendations.

C. HIGHWAY FUNCTION AND CLASSIFICATION

A determination of the function and operational requirements, and a clear definition of the classification of each new facility are required prior to the actual design.

C.1 Function

Design of each new street or highway is based upon its function in the highway system. Operational requirements that must be satisfied to fulfill this function are dependent upon the following factors:

C.1.a. Volume

Volume of traffic that must be carried by the facility is a primary factor governing the design. Variations in volume with respect to direction and time should also be evaluated to determine the expected requirements for peak capacities.

C.1.b. Highway User Types

Types and relative volumes of highway users expected to use the street or highway influence trip characteristics and design features.

C.1.c. Trip Characteristics

Functions of a new facility are, to a large extent, determined by the length and purpose of vehicle trips. Trip characteristics are influenced by land use characteristics and the highway network layout.

C.1.d. Speed

Operating speed (to be maintained) should meet reasonable expectations of the users.

C.1.e. Safety

Provisions of streets and highways with safe operating characteristics shall be considered a primary requirement.

C.1.f. Level of Service

Level of service is essentially a measure of the quality of the overall operating characteristics of a street or highway. Factors involved in determining the level of service include speed and safety, as well as travel time; traffic conflicts and interruptions; freedom to maneuver; driving convenience and comfort; and operating costs. Level of service is also dependent upon actual traffic volume and composition of traffic.

C.1.g. Access Requirements

Degree and type of access permitted on a given facility is dependent upon its intended function and should conform to the guidelines in CHAPTER 3 - GEOMETRIC DESIGN. Reasonable access control must be exercised to allow a street or highway to fulfill its function.

C.1.h. Public Transit Use

Both current and planned use by public transit influence design features. Transit vehicles increase capacity on a roadway. There must be the ability to safely stop along the roadway to board and discharge passengers.

C.2 Classification

Road classifications are defined in Section 334.03, Florida Statutes. Functional classification is the assignment of roads into systems according to the character of service they provide in relation to the total road network.

C.2.a. Basic Classification

Basic functional categories include arterial, collector, and local roads which may be subdivided into principal, major, or minor levels. These levels may be additionally divided into rural and urban categories. This basic classification system is utilized throughout this Manual.

C.2.a.1 Local

A route providing service which is of relatively low average traffic volume, short average trip length or minimal through-traffic movements, and high land access for abutting property.

C.2.a.2 Collector

A route providing service which is of relatively moderate average traffic volume, moderately average trip length, and moderately average operating speed. These routes also collect and distribute traffic between local roads or arterial roads and serve as a linkage between land access and mobility needs.

C.2.a.3 Arterial

A route providing service which is relatively continuous and of relatively high traffic volume, long average trip length, generally higher operating speed, and high mobility importance. In addition, all United States numbered highways shall be arterial roads.

C.2.b. Classification Modifications

Design and classification of streets and highways should also be based upon a consideration of highway user expectations. The function of any facility, as perceived by the user, essentially determines the driver's willingness to accept restrictions upon speed, capacity, access, or level of service. Basic classification systems may also be modified by the following variables:

C.2.b.1 Urban

Urban area highway users will generally accept lower speeds and levels of service. Economic constraints in urban areas are also generally more severe. Minor modifications in design criteria are, therefore, appropriate for urban streets.

C.2.b.2 Major/Minor

Streets and highways may be classified as major or minor depending upon traffic volume, trip length, and mobility.

D. OPERATION

The concept of operating the existing highway network as a system is essential to promote safety, efficiency, mobility, and economy. This requires comprehensive planning and coordination of all activities on each street and highway. These activities would include maintenance, construction, utility operations, public transit operations, traffic control, and emergency response operations. Although the behavior of the individual motorist is somewhat independent, driver actions and response should also be considered as an integral part of the operation of streets and highways. Coordination of the planning and supervision of each activity on each facility is necessary to achieve safety and efficient operation of the total highway system.

D.1 Policy

Each highway agency with general responsibility for existing streets and highways should establish and maintain an operations department. Each existing street or highway should be assigned to the jurisdiction of the operations department. The operations department shall be responsible for planning, supervising, and coordinating all activities affecting the operating characteristics of the highway system under its jurisdiction.

D.2 Objectives

The primary objective of an operations department shall be to maintain or improve the operating characteristics of the highway system under its jurisdiction. These characteristics include safety, capacity, and level of service. The preservation of the function of each facility, which would include access control, is necessary to maintain these characteristics and the overall general value of a street or highway.

D.3 Activities

The achievement of these objectives requires the performance of a variety of coordinated activities by the operations department. The following activities should be considered as minimal for promoting the safe and efficient operation of a highway system.

D.3.a. Maintenance and Reconstruction

Maintenance or upgrading the quality of existing facilities is an essential factor in preserving desirable operating characteristics. The planning and execution of maintenance and reconstruction activity on existing facilities must be closely coordinated with all other operational activities and, therefore, should be under the general supervision of the operations department.

All maintenance work should be conducted in accordance with the requirements of CHAPTER 10 - MAINTENANCE. The priorities and procedures utilized should be directed toward improvement of the existing system. The standards set forth in this Manual should be used as guidelines for establishing maintenance and reconstruction objectives. All maintenance and reconstruction projects should be planned to minimize traffic control conflicts and hazards.

D.3.b. Work Site Safety

An important responsibility of the operations department is the promotion of work site safety on the existing highway system. The planning and execution of maintenance, construction, and other activities shall include provisions for the safety of motorists, bicyclists, pedestrians, and workmen. All work shall be conducted in accordance with the requirements presented in CHAPTER 11 - WORK SITE SAFETY.

D.3.c Traffic Control

Traffic engineering is a vital component of highway operations. The planning and design of traffic control devices should be carried out in conjunction with the overall design of the street or highway and highway user. The devices and procedures utilized for traffic control should be predicated upon developing uniformity throughout the system and compatibility with adjacent jurisdictions.

A primary objective to be followed in establishing traffic control procedures is the promotion of safe, orderly traffic flow. The cooperation of police agencies and coordination with local transit providers is essential for the achievement of this objective. Traffic control during maintenance, construction, utility, or emergency response operations should receive special consideration.

D.3.d Emergency Response

The emergency response activities (i.e., emergency maintenance and traffic control) of the operations department should be closely coordinated with the work of police, fire, ambulance, medical, and other emergency response agencies. The provisions for emergency access and communications should be included in the initial planning for these activities.

D.3.e. Coordination and Supervision

Coordination and supervision of activities on the highway system should include the following:

- Supervision and/or coordination of all activities of the operations department and other agencies to promote safe and efficient operation

- Coordination of all activities to provide consistency within a given jurisdiction
- Coordination with adjacent jurisdictions to develop compatible highway systems
- Coordination with other transportation modes to promote overall transportation efficiency

D.3.f Inspection and Evaluation

The actual operation of streets and highways provides valuable experience and information regarding the effectiveness of various activities. Each operations department should maintain a complete inventory of its highway system and continuously inspect and evaluate the priorities, procedures, and techniques utilized in all activities on the existing system under its jurisdiction. Activities by other agencies, as well as any highway agency, should be subjected to this supervision.

Promotion of highway safety should be aided by including a safety office (or officer) as an integral part of the operations department. Functions of this office would include the identification and inventory of hazardous locations and procedures for improving the safety characteristics of highway operations.

Results of this inspection and evaluation program should be utilized to make the modification necessary to promote safe and efficient operation. Feedback for modifying design criteria should be generated by this program. Experience and data obtained from operating the system should be utilized as a basis for recommending regulatory changes. Cooperation of legislative, law enforcement, and regulatory agencies is essential to develop the regulation of vehicles, driver behavior, utility, emergency response activities, and the access land use practices necessary for the safe and efficient operation of the highway system.

CHAPTER 2

LAND DEVELOPMENT

A. INTRODUCTION

A major portion of street and highway construction and reconstruction is generated by, and is accomplished as a result of, land development for residential, commercial, industrial, and public uses. The general land use layout influences, and is controlled by, connections with adjacent highway networks with different transportation modes. Techniques, principles, and general layout used for any development also dictate the resulting internal highway network. The arrangement and space allocations for this network may determine whether safe, efficient, and economical streets and highways are constructed or reconstructed.

Some land development practices do not promote the creation of a high quality highway network. Poor development layouts often result in streets and highways with bad alignment, insufficient sight distance, and inadequate cross section. Insufficient space allocations result in cramped, hazardous intersections, narrow roadside clear zones, and inadequate room for future modifications and expansions. Failure to provide reasonable control of access causes hazardous operating conditions and a dramatic reduction in the capacity and economic value of streets and highways.

Although there are many conflicting demands in land development, the provision of an adequate highway network is essential in preserving the social and economic value of any area. Development controls are needed to aid in the establishment of safe streets and highways that will retain their efficiency and economic worth. Provisions for adequate alignment, right of way, setbacks, expansion, and access control are essential.

It is recognized there are many legal, social, and economic problems involved in land use controls. Proper coordination among the public, various governmental bodies, and public transit and highway agencies should, however, allow for the solution of many problems. Implementation of responsible land use and development regulations along with intergovernmental respect for the goals and objectives of each, will promote a superior, long term transportation network.

B. OBJECTIVES

Provisions for vehicular and pedestrian safety are important objectives to be considered in land development. Other land development objectives, related to surface transportation, should include the promotion of smooth traffic flow, efficiency, economy, aesthetics, and environmental compatibility of the transportation network.

General objectives for land development that should be followed to promote good highway design include the following:

- Preserve the function of each street and highway (i.e., use of arterial and collector streets for local circulation seriously compromises safety and capacity)
- Provide for smooth, logical, and energy efficient traffic types and flow patterns
- Provide for the appropriate vehicular speed
- Reduce traffic conflicts to a minimum and eliminate confusion
- Allow for the application of safe geometric design principles
- Provide for bicycle and pedestrian safety
- Provide for future modifications and expansion
- Provide for aesthetic and environmental compatibility
- Develop economic design, construction, and maintenance strategies
- Provide for appropriate public transit facilities

C. PRINCIPLES AND GUIDELINES

There are many variables involved in land development; therefore, specific standards and requirements for land use and highway network layouts cannot always be applied. Use of sound principles and guidelines can, however, aid in meeting the objectives of a better highway network. Proper planning and design of the development layout are necessary to provide a satisfactory highway network and to allow for the construction of safe

roadways. The following principles and guidelines should be utilized in the design of the highway network, in the control of access, and in the land use controls and space allocation that would affect vehicular and pedestrian use.

C.1 Network Design

The general layout of the highway network establishes the traffic flow patterns and conflicts, thereby determining the basic safety and efficiency criteria. The design of the highway network should be based on the following principles:

- The layout of street and highway systems should be logical and easily understood by the user.
- The design and layout of all streets and highways should clearly indicate their function (arterial, collector, etc.).
- Local circulation patterns should be compatible with adjacent areas. Arterials and collectors should not be interrupted or substantially altered at development or jurisdictional boundary lines.
- Flow patterns should be designed to interconnect neighborhoods while discouraging through motorized traffic from local street networks.
- Elements in the local circulation should be adequate to avoid the need for extensive traffic controls.
- Often there are streets where abuse of posted speed becomes an enforcement problem and can have a negative safety impact on the circulation within an urban network. In other situations, there are community concerns with controlling speed levels such as in areas of concentrated pedestrian activities, those with narrow right of way, areas with numerous access points, on street parking, and other similar concerns. Local authorities may elect to use traffic calming design features which could include, but not be limited to, the installation of speed humps, speed tables, chicanes, or other pavement undulations. Roundabouts are also another method of dealing with this issue at intersections. These traffic calming design features are not considered traffic control design features as defined by the MUTCD.

The internal circulation should be sufficient to provide reasonable travel distance for local trips.

- The highway network should be compatible with other transportation modes such as mass transit and pedestrian and bicycle facilities. Conflicts between different modes (particularly with pedestrian and bicycle traffic) should be kept to a minimum.
- The highway network layout should be designed to reduce internal traffic and pedestrian conflicts and eliminate confusion. Particular emphasis should be directed toward eliminating substantial speed differentials and hazardous turning and crossing maneuvers. The following principles should be utilized for conflict reduction:
 - Generally the number of intersections should be kept to a minimum but should meet land use needs and flow requirements.
 - Local one-way streets are an option to consider where feasible.
 - Local streets should be designed to limit vehicle speeds (length, width, alignment, and intersections).
 - The network should be designed to reduce the number of crossings and left turn maneuvers that are required.

C.2 Access Control

The standards and requirements presented in CHAPTER 3 - GEOMETRIC DESIGN, are absolutely necessary to maintain safe and efficient streets and highways. Failure to provide adequate control of access has seriously damaged many existing roadways. Unrestricted access to major collectors and arterials has dramatically reduced their capacity and general economic value. The safety characteristics of these facilities have similarly been diminished by significantly increasing the number of vehicular, pedestrian, and bicycle traffic conflicts.

The utilization of proper control over access is one of the most effective and economical means for maintaining the safety and utility of streets and highways. The procedures and controls used for land development significantly affect access control. The following principles should be utilized in the formation of land use controls for limiting access:

- The standards presented in CHAPTER 3 - GEOMETRIC DESIGN, C.8 Access Control, should provide the basis for establishing land development criteria for control of access.
- The use of a street or highway as an integral part of the internal circulation pattern on private property should be prohibited.
- The intersection of private roads and driveways with public facilities should be strictly controlled.
- Access to facilities which generate major traffic (vehicular, pedestrian, and bicycle), should be located to provide the minimum conflict with other traffic. These generators include schools, shopping centers, business establishments, industrial areas, entertainment facilities, etc.
- Commercial strip development, with the associated proliferation of driveways, should be eliminated. Interconnective and improvements to sidewalks should be encouraged.
- The function of all streets and highways should be preserved by the application of the appropriate access controls.
- The spacing and location of access points should be predicated upon reducing the total traffic and pedestrian conflict.
- Hazardous maneuvers should be restricted by access controls. For example, crossing and left turn maneuvers may be controlled by continuous median separation. Pedestrian access should be allowed at appropriate intervals. This includes medians with waiting space for pedestrians crossing the street.

C.3 Land Use Controls and Space Allocation

The provisions for adequate space and proper location of various activities is essential to promote safety and efficiency. The following guidelines should be utilized in land use:

- Adequate corridors and space should be considered for utilities. Utility locations should be carefully chosen to minimize interference with the operation of the streets, highways, and sidewalks.
- Adequate space for drainage facilities should be provided. Open drainage

facilities should be located well clear of the traveled way.

- Design for pedestrian and bicycle facilities should comply with Chapters 8 and 9 of this Manual.
- Adequate space should be provided for off-street and side-street parking. This is essential in commercial and industrial areas.
- Right of way and setback requirements should be adequate to provide ample sight distance at all intersections.
- Sufficient space should be allocated for the development of adequate intersections.
- Space allocation for street lighting (existing or planned) should be incorporated into the initial plan. Supports for this lighting should be located outside of the required clear zone unless they are clearly of breakaway type, or are guarded by adequate protective devices. Lighting plans should provide for well-lit, safe waiting and walking areas and shall conform with the provisions of Chapter 6 of this Manual.
- Sufficient right of way should be provided for future widening, modification, or expansion of the highway network.
- Adequate corridors for future freeways, High Occupancy Vehicle(HOV) lanes, arterials, or major collectors should be provided.
- Adequate space for desired or required greenways should be provided.
- Adequate space for appropriate public transit facilities.

D. CONFLICT AND COORDINATION

There are many demands that tend to conflict with the development of safe and efficient streets and highways. Meeting the demand for access can frequently destroy the capacity of a roadway. Pressure to limit the amount of land dedicated for streets and highways inhibits the construction of an adequate highway system. Coordination between highway agencies and other governmental bodies can, however, assist in improving the procedures used in land development. Proper coordination should be solicited from legislative bodies, courts, planning and zoning departments, and transit and other governmental agencies to

aid in guaranteeing a well designed and adequate highway network. Coordination with transit planners, developers, engineers, architects, contractors, and other private individuals, which is also beneficial, should be a continuous process.

E. CONTROL TECHNIQUES

The implementation of a sound highway transportation plan requires certain controls. A logical network design, adequate access controls, and proper land use controls are dependent upon and foster proper land development practices. Techniques that may be utilized to establish these necessary controls include the following:

E.1 Right of Way Acquisition

The acquisition of sufficient right of way is essential to allow for the construction of adequate streets and highways as specified in CHAPTER 3 - GEOMETRIC DESIGN and CHAPTER 4 - ROADSIDE DESIGN. The provision of adequate space for clear roadside, sight distance, drainage facilities, buffer zones, intersections, transit, sidewalks, frontage roads, and future expansion is also necessary to develop and maintain safe streets and highways.

E.2 Police Power

The regulatory authority of state and local highway agencies (and other related agencies) should be sufficient to implement the necessary land use controls. The following general regulatory requirements and specific areas of control should be considered as minimum:

E.2.a General Regulatory Requirements

The necessary elements for achieving the following transportation goals should be incorporated into all land use and zoning ordinances:

- General highway transportation plans should be created and implemented.
- Determination and acquisition of transportation corridors for future expansions is essential.
- Development plans clearly showing all street and highway layouts, transit facilities, pedestrian and bicycle facilities, and utility corridors

should be required. The execution of these plans should be enforceable.

- Development plans, building permits, and zoning should be reviewed by the appropriate agency.
- A safety check of proposed streets and highways should be a required step in the review and acceptance of all development plans.

E.2.b Specific Control

Specific areas of control necessary to develop adequate and efficient roadways include the following:

- Land use control and development regulations
- Control of access
- Driveway design
- Street and highway layouts
- Location of vehicular and pedestrian generators
- Location of transit, pedestrian, and bicycle facilities
- Right of way and setback requirements for sight distances and clear zone
- Provisions for drainage

E.3 Contracts and Agreements

Where land purchase or regulatory authority is not available or appropriate, the use of contractual arrangements or agreements with individuals can be beneficial. Negotiations with developers, builders, and private individuals should be used, where appropriate, to aid in the implementation of the necessary controls.

E.4 Education

Education of the public, developers, and governmental bodies can be beneficial in promoting proper land development controls. The need for future planning, access

control, and design standards should be clearly and continuously emphasized. Successful solidification of the cooperation of the public and other governmental bodies depends upon clear presentation of the necessity for reasonable land development controls.

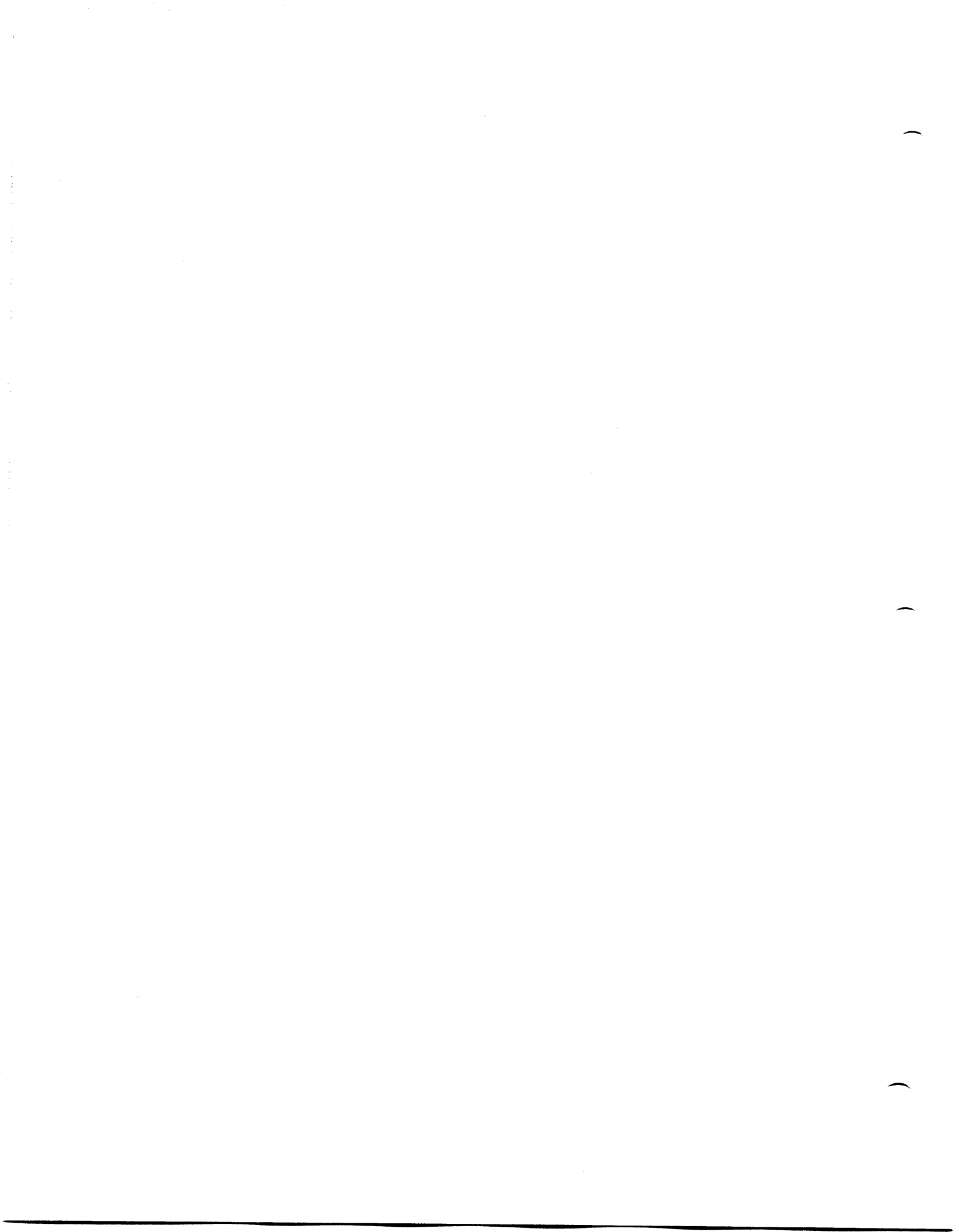

CHAPTER 3

GEOMETRIC DESIGN

A. INTRODUCTION

Geometric design is defined as the design or proportioning of the visible elements of the street or highway. The geometry of the roadway is of central importance since it provides the framework for the design of other highway elements. In addition, the geometric design establishes the basic nature and quality of the vehicle path which has a primary effect upon the overall safety characteristics of the street or highway.

In order to achieve a total design which is consistent and safe, the design of roadway geometry must be conducted in close coordination with other design elements. These other elements would include: pavement design, roadway lighting, traffic control devices, transit, drainage, and structural design. The design should consider safe roadside clear zones, pedestrian safety, emergency response, and maintenance capabilities.

The safety characteristics of the design should be given primary consideration. The initial establishment of sufficient right of way and adequate horizontal and vertical alignment is not only essential from a safety standpoint, but also necessary to allow future upgrading and expansion without exorbitant expenditure of highway funds.

The design elements selected should be reasonably uniform but should not be inflexible.

The minimum standards presented in this Chapter should not automatically become the standards for geometric design. The designer should consider use of a higher level, when practical, and consider cost-benefits as well as consistency with adjacent facilities. Reconstruction and maintenance of facilities should, where practical, include upgrading to these minimum standards.

In restricted or unusual conditions, it may not be possible to meet the minimum standards. In such cases, the designer must obtain an exception in accordance with Chapter 14 from the reviewing or permitting organization. However, every effort should be made to obtain the best possible alignment, grade, sight distance, and proper drainage consistent with the terrain, the development, safety, and fund availability. The concept of highway users has expanded in recent years creating additional concerns for the designer.

In making decisions on the standards to be applied to a particular project, the designer must also now address the needs of pedestrians, transit, bicyclists, elder road users, the

disabled, and other users. This is true for both urban and rural facilities.

The design features of urban local streets are governed by practical limitations to a greater extent than those of similar roads in rural areas. The two dominant design controls are: (1) the type and extent of urban development and its limitations on rights of way and (2) zoning or regulatory restrictions. Some streets primarily are land service streets in residential areas. In such cases, the overriding consideration is to foster a safe and pleasing environment. Other streets are land service only in part, and features of traffic and public transit service may be predominant.

The selection of the type and exact design details of a particular roadway or highway requires considerable study and thought. When reference is made to guidelines and design details given by current American Association of State Highway and Transportation Officials (AASHTO) publications, these guidelines and standards should generally be considered as minimum criteria. For the design of recreational roads, local service roads, and alleys, see AASHTO publications.

Right of way and pavement width requirements for new construction may be reduced for the paving of certain existing unpaved subdivision streets and low volume rural roads provided all of the conditions listed below are satisfied:

- The road is functionally classified as a local road.
- The 20 year projected ADT is less than 750 vehicles per day and the design year projected peak hourly volume is 100 vehicles per hour or less. Note: The design year may be any time within a range of the present to 20 years in the future, depending on the nature of the improvement.
- The road has no foreseeable probability of changing to a higher functional classification through changes in land use, extensions to serve new developing land areas, or any other use which would generate daily or hourly traffic volumes greater than those listed above.
- There is no reasonable possibility of acquiring additional right of way without:
 - Incurring expenditures of public funds in an amount which would be excessive compared to the public benefits achieved
 - Causing substantial damage or disruption to abutting property improvements to a degree that is unacceptable considering the local environment

B. OBJECTIVES

The major objective in geometric design is to establish a vehicle path and environment providing a reasonable margin of safety for the motorist, transit, bicyclist, and pedestrian under the expected operating conditions and speed. It is recognized that Florida's design driver is aging and tourism is our major industry. This gives even more emphasis to focus on simplicity and easily understood geometry and roadway features. The achievement of this objective may be realized by meeting certain specific objectives, which include the following:

- Provide the simplest geometry attainable, consistent with the physical constraints
- Provide a design that has a reasonable and consistent margin of safety at the expected operating speed
- Provide a design that is safe at night and under adverse weather conditions
- Provide a facility that is adequate for the expected traffic conditions and transit needs
- Allow for reasonable deficiencies in the driver, such as:
 - Periodic inattention
 - Reduced skill and judgment
 - Slow reaction and response
- Provide an environment that minimizes hazards, is as hazard free as practical, and is "forgiving" to a vehicle that has deviated from the travel path or is out of control.

C. DESIGN ELEMENTS

C.1. DESIGN SPEED

The design speed is defined as the maximum safe speed that can be maintained over a given section of highway when weather, light, and traffic conditions are such that the design features of the highway govern. The basic purpose in using the

design speed concept is to achieve consistency in the various design elements that influence vehicle operations. Since many critical design features (e.g., sight distance and curvature) are predicated upon design speed, the selection of the proper value is essential to allow for the safe design of a street or highway.

The selection of an appropriate design speed is dependent on the predicted driver behavior and is, therefore, rather complex. This selection of design speed should receive considerable preliminary investigation and thought so safety will be realized from the design.

The primary basis for selecting the design speed should be a rational prediction of the probable maximum operating speed (by approximately 90 percent of the vehicles) on the street or highway. The "average running speed" is not acceptable as a design speed.

In selecting design speeds, consideration should also be given to pedestrians and bicycle usage and to the present and future adjacent land use.

Recommended minimum values for design speed are given in Table 3 - 1. These values should be considered as general guidelines only. The maximum normal operating speed is dependent on many variables including:

- Topography
- General roadway geometry
- Surrounding land use
- Degree of access
- Frequency of traffic signals or other traffic control devices
- Posted speed limit and the degree of enforcement

The driver does not necessarily adjust speed to the classification of importance (or lack of it) of the street or highway.

The design speed shall not be less than the expected posted or legal speed limit. A design speed 5 mph to 10 mph greater than the posted speed limit will compensate for a slight overrunning of the speed limit by some drivers.

The use of the higher design speed (no speed restrictions) given in Table 3 - 1 is recommended for the following situations:

- Topography allowing or encouraging higher operating speeds
- Roadway geometry permitting high speeds
- Long uninterrupted sections of roadway

The design speed utilized should be consistent over a given section of highway. Required changes in design speed should be effected in a gradual fashion. When isolated reductions in design speed cannot reasonably be avoided, appropriate speed signs should be posted.

C.2. Design Vehicles

A “design vehicle” is a selected motor vehicle whose weight, dimensions, and operating characteristics are used to establish highway design controls to accommodate vehicles of a designated type. For the purpose of geometric design, the design vehicle should be one with dimensions and minimum turning radii larger than those of almost all vehicles in its class. Design vehicles are listed in Table 3 - 2. One or more of these vehicles should be used as a control in the selection of geometric design elements. In certain industrial (or other) areas, special service vehicles may have to be considered in the design. Fire equipment and emergency vehicles should have reasonable access to all areas.

If a significant number or percentage (5 percent of all the total traffic) of vehicles of those classes larger than passenger vehicles are likely to use a particular street or highway, that class should be used as a design control. The design of major arterial streets and highways should normally be adequate to accommodate all design vehicles. The decision as to which of the design vehicles (or other special vehicles) should be used as a control is complex and requires careful study. Each situation must be evaluated individually to arrive at a reasonable estimate of the type and volume of expected traffic.

- Design criteria significantly affected by the type of vehicle include:
- Horizontal and vertical clearances
- Alignment
- Lane widening on curves

- Shoulder width requirements
- Turning roadway and intersection radii
- Intersection sight distance
- Acceleration criteria

Particular care should be taken in establishing the radii at intersections, so vehicles may enter the street or highway without encroaching on adjacent travel lanes or leaving the pavement. It is acceptable for occasional trucks or buses to make use of both receiving lanes, especially on side streets.

C.3. Sight Distance

The provision for adequate horizontal and vertical sight distance is an essential factor in the development of a safe street or highway. An unobstructed view of the upcoming roadway is necessary to allow time and space for the safe execution of passing, stopping, intersection movements, and other normal and emergency maneuvers. It is also important to provide as great a sight distance as possible to allow the driver time to plan for future actions. The driver is continuously required to execute normal slowing, turning, and acceleration maneuvers. If he can plan in advance for these actions, traffic flow will be smoother and less hazardous. Unexpected emergency maneuvers will also be less hazardous if they are not combined with uncertainty regarding the required normal maneuvers. The appropriate use of lighting (CHAPTER 6 - ROADWAY LIGHTING) may be required to provide adequate sight distances for night driving.

Future obstruction to sight distance that may develop (e.g., vegetation) or be constructed should be taken into consideration in the initial design. Areas outside of the highway right of way that are not under the highway agency's jurisdiction should be considered as points of obstruction. Planned future construction of median barriers, guardrails, grade separations, or other structures should also be considered as possible sight obstructions.

C.3.a. Stopping Sight Distance

Safe stopping sight distances shall be provided continuously on all streets and highways. The factors which determine the minimum distance required to stop include:

- Vehicle speed

- Driver's total reaction time
- Characteristics and conditions of the vehicle
- Friction capabilities between the tires and the roadway surface
- Vertical and horizontal alignment of the roadway

It is desirable that the driver be given sufficient sight distance to avoid an object or slow moving vehicle with a natural, smooth maneuver rather than an extreme or panic reaction.

The determination of available stopping sight distance shall be based on a height of the driver's eye equal to 3.50 feet and a height of obstruction to be avoided equal to 0.50 feet. It would, of course, be desirable to use a height of obstruction equal to zero (coincident with the roadway surface) to provide the driver with a more positive sight condition. Where horizontal sight distance may be obstructed on curves, the driver's eye and the obstruction shall be assumed to be located at the centerline of the travel lane on the inside of the curve.

The stopping sight distance shall be no less than the values given in Table 3 - 6.

C.3.b. Passing Sight Distance

The passing maneuver, which requires occupation of the opposing travel lane, is inherently dangerous. The driver is required to make simultaneous estimates of time, distance, relative speeds, and vehicle capabilities. Errors in these estimates result in frequent and serious crashes.

Highways with two or more travel lanes in a given direction are not subject to requirements for safe passing sight distance. Two-lane, two-way highways should be provided with safe passing sight distance for as much of the highway as feasible. The driver demand for passing opportunity is high and serious limitations on the opportunity for passing reduces the capacity and safe characteristics of the highway.

The distance traveled after the driver's final decision to pass (while encroaching into the opposite travel path) is that which is required to pass and return to the original travel lane in front of the overtaken vehicle. In

addition to this distance, the safe passing sight distance must include the distance traveled by an opposing vehicle during this time period, as well as a reasonable margin of safety. Due to the many variables in vehicle characteristics and driver behavior, the passing sight distance should be as long as is practicable.

The determination of passing sight distance shall be based on a height of eye equal to 3.50 feet and a height of object passing equal to 4.25 feet. Where passing is permitted, the passing sight distance shall be no less than the values given in Table 3 - 6.

C.3.c. Sight Distance at Decision Points

It is desirable to provide sight distances exceeding the minimum at changes in geometry, approaches to intersections, entrances and exits, and other potential decision points or hazards. The sight distance should be adequate to allow the driver sufficient time to observe the upcoming situation, make the proper decision, and take the appropriate action in a normal manner.

Minimum stopping distance does not provide sufficient space or time for the driver to make decisions regarding complex situations requiring more than simple perception-reaction process. In many cases, rapid stopping or lane changing may be extremely undesirable and cause hazardous maneuvers (i.e., in heavy traffic conditions), therefore, it would be preferable to provide sufficient sight distance to allow for a more gradual reaction.

The sight distance on a freeway preceding the approach nose of an exit ramp should exceed the minimum by 25 percent or more. A minimum sight distance of 1000 feet, measured from the driver's eye to the road surface is a desirable goal. There should be a clear view of the exit terminal including the exit nose.

C.3.d. Intersection Sight Distance

Sight distance for intersection movements are given in the general intersection requirements.

C.4. Horizontal Alignment

C.4.a. General Criteria

The standard of alignment selected for a particular section of highway should extend throughout the section with no sudden changes from easy to sharp curvature. Where sharper curvature is unavoidable, a sequence of curves of increasing degree should be utilized.

Winding alignment consisting of sharp curves is hazardous, reduces capacity, and should be avoided. The use of as flat a curve as possible is recommended. Flatter curves are not only less hazardous, but also frequently less costly due to the shortened roadway.

Maximum curvature should not be used in the following locations:

- High fills or elevated structures. The lack of surrounding objects reduces the driver's perception of the roadway alignment.
- At or near a crest in grade
- At or near a low point in a sag or grade
- At the end of long tangents
- At or near intersections, transit stops, or points of ingress or egress
- At or near other decision points

The "broken back" arrangement of curves (short tangent between two curves in the same direction) should be avoided. This is acceptable only at design speeds of 30 mph or less. This arrangement produces an unexpected and hazardous situation.

When reversals in alignment are used and superelevation is required, a sufficient length of tangent between the reverse curves is required for adequate superelevation transition.

Compound curves should be avoided, especially when curves are sharp.

They tend to produce erratic and dangerous vehicle operations. When compound curves are necessary, the radius of the flatter curve should not be more than 50 percent greater than the sharper curve.

The transition between tangents and curves should normally be accomplished by the use of appropriate straight line transitions or spirals. This is essential to assist the driver in maintaining his vehicle in the proper travel path.

For small deflection angles, curves should be suitably lengthened to avoid the distracting appearance of a kink. Curves should be at least 900 feet long for a central angle of 1 degree or 500 feet long for a central angle of 5 degrees. Gently flowing alignment is generally more pleasing in appearance, as well as, superior from a safety standpoint.

C.4.b. Superelevation

In the design of highway curves, it is necessary to establish a proper relationship between curvature of the roadway and design speed. The use of superelevation (rotation of the roadway about its axis) is employed to counteract centrifugal force and allow drivers to comfortably and safely travel through curves at the design speed.

The superelevation rates for rural highways, urban freeways, and high speed urban arterials are shown in Figure 3 - 1. These rates are based on a maximum rate of 0.10 foot per foot of roadway width. Additional superelevation details, given in FDOT Roadway and Traffic Design Standards , may be considered.

The superelevation rates recommended for urban highways are shown in Figure 3 -2. These rates are based on a maximum superelevation rate of 0.05 foot per foot of roadway width and are recommended for major streets in built up areas. Additional information regarding superelevation, given in FDOT Roadway and Traffic Design Standards, and AASHTO - "A Policy on Geometric Design of Highways and Streets" -1990, may be considered.

Although superelevation is advantageous for traffic operations, various factors combine to make its use impractical in many built-up areas. Such factors include:

- Wide pavement areas

- Need to meet grade of adjacent property
- Surface drainage considerations
- Frequency of cross streets, alleys, and driveways

Therefore, horizontal curves on lower speed streets in subdivision and urban areas are usually designed without superelevation, only side friction being used to counteract the centrifugal force. Figure 3 - 2 may be used for determination of the maximum safe speed for horizontal curves on lower speed urban streets.

C.4.c. Curvature

Where a directional change in alignment is required, every effort should be made to utilize the smallest degree (largest radius) curve possible. The use of the maximum degree of curvature should be avoided when possible. Design speed maximum degree of curve relationships are given in Table 3 - 3. The use of sharper curvature for the design speeds shown in Table 3 - 3 would call for superelevation beyond the limit considered practical or for operation with tire friction beyond safe or comfortable limits or both. The maximum degree of curvature is a significant value in alignment design.

C.4.d. Superelevation Transition (superelevation runoffs plus tangent runoff)

Superelevation runoff is the general term denoting the length of highway needed to accomplish the change in cross slope from a section with the adverse crown removed (level) fully superelevated section, or vice versa. Tangent runoff is the general term denoting the length of highway needed to accomplish the change in cross slope from a normal cross section to a section with the adverse crown removed, or vice versa. Spiral curves can be used to transition from the tangent to the curve. Where the spiral curve is employed, its length is used to make the entire superelevation transition.

FDOT Roadway and Traffic Design Standards show in detail superelevation transitions for various sections and methods for determining length of transition.

C.4.e. Lane Widening on Curves

The travel lane should be widened on sharp curves due to the increased difficulty for the driver to follow the proper path. Trucks and transit vehicles experience additional difficulty due to the fact that the rear wheels may track considerably inside the front wheels thus requiring additional width. Adjustments to lane widths for mainline and turning roadways are given in Table 3-20. A transition length shall be introduced in changing to an increased/decreased lane width. This transition length shall be proportional to the increase/decrease in pavement width in a ratio of not less than 50 feet of transition length for each foot of change in lane width.

C.5. Vertical Alignment

C.5.a. General Criteria

The selection of vertical alignment should be predicated to a large extent upon the following criteria:

- Obtaining maximum sight distances
- Limiting speed differences (particularly for trucks and buses) by reducing magnitude and length of grades
- A "hidden dip" which would not be apparent to the driver must be avoided.
- Steep grades and sharp crest vertical curves should be avoided at or near intersections.
- Flat grades and long gentle vertical curves should be used whenever possible.

C.5.b. Grades

The grades selected for vertical alignment should be as flat as practical, and should not be greater than the value given in Table 3 - 4.

For streets and highways requiring long upgrades, the maximum grade should be reduced so the speed reduction of slow-moving vehicles (e.g., trucks and buses) is not greater than 10 mph. The critical lengths of grade

for these speed reductions are shown in Figure 3 - 3. Where reduction of grade is not practical, climbing lanes should be provided to meet these speed reduction limitations.

The criteria for a climbing lane and the adjacent shoulder are the same as for any travel lane except that the climbing lane should be clearly designated by the appropriate pavement markings. Entrance to and exit from the climbing lane shall follow the same criteria as other merging traffic lanes; however, the climbing lane should not be terminated until well beyond the crest of the vertical curve. Differences in superelevation should not be sufficient to produce a change in pavement cross slope between the climbing lane and through lane in excess of 0.04 feet per foot.

Recommended minimum gutter grades:

Rolling terrain - 0.5%

Flat terrain - 0.03%

C.5.c. Vertical Curves

Changes in grade should be connected by a parabolic curve (the vertical offset being proportional to the square of the horizontal distance). Vertical curves are required when the algebraic difference of intersecting grades exceeds the values given in Table 3 - 5. The length of vertical curve on a crest, as governed by stopping sight distance, is obtained from Figure 3 - 4. The minimum length of a crest vertical curve to obtain minimum passing sight distance is given in Figure 3 - 5. The minimum length of a sag vertical curve, as governed by vehicle headlight capabilities, is obtained from Figure 3 - 6.

Wherever feasible curves longer than the minimum should be considered to improve both aesthetic and safety characteristics.

C.6. Alignment Coordination

Horizontal and vertical alignment should not be designed independently. Poor combinations can spoil the good points of a design. Properly coordinated horizontal and vertical alignment can improve appearance, enhance community values, increase safety, and encourage uniform speed. Coordination of horizontal and vertical alignment should begin with preliminary design, during which stage adjustments can be readily made.

Proper combinations of horizontal alignment and profile can be obtained by engineering study and consideration of the following general controls:

Curvature and grades should be in proper balance. Tangent alignment or flat curvature with steep grades and excessive curvature with flat grades are both poor design. A logical design is a compromise between the two conditions. Wherever feasible the roadway should "roll with" rather than "buck" the terrain.

Vertical curvature superimposed on horizontal curvature, or vice versa, generally results in a more pleasing facility, but it should be analyzed for effect on driver's view and operation. Changes in profile not in combination with horizontal alignment may result in a series of disconnected humps to the driver for some distance.

Sharp horizontal curvature should not be introduced at or near the top of a pronounced crest vertical curve. Drivers cannot perceive the horizontal change in alignment, especially at night. This condition can be avoided by setting the horizontal curve so it leads the vertical curve or by making the horizontal curve longer. Suitable design can be made by using design values well above the minimums.

Sharp horizontal curvature should not be introduced at or near the low point of a pronounced sag vertical curve to prevent an undesirable distorted appearance. Vehicle speeds are often high at the bottom of grades and erratic operation may result, especially at night.

On divided highways, variation of the median width and the use of independent vertical and horizontal alignment should be considered. Where right of way is available, a superior design without significant additional costs, can result from the use of independent alignment.

Horizontal alignment and profile should be made as flat as possible at interchanges and intersections where sight distance along both highways is important. Sight distances above the minimum are desirable at these locations.

Alignment should be designed to enhance scenic views for the motorists.

In residential areas, the alignment should be designed to minimize nuisance to the neighborhood.

C.7. Cross Section Elements

The design of the highway cross section should be predicated upon the design speed, terrain, adjacent land use, classification and the type and volume of traffic

expected. The cross section selected should be uniform throughout a given length of street or highway without frequent or abrupt changes.

C.7.a. Number of Lanes

The number of travel lanes is determined by several interrelated factors such as capacity, level of service, and service volume. (AASHTO "A Policy on Geometric Design of Highways and Streets" - latest edition, and the current "Highway Capacity Manual")

C.7.b. Pavement

The paved surface of all travel lanes shall be designed and constructed in accordance with the requirements set forth in CHAPTER 5 - PAVEMENT DESIGN, CONSTRUCTION, AND MAINTENANCE.

C.7.b.1. Pavement Width

Traffic lanes should be 12 feet in width, but shall not be less than 10 feet in width. Streets and highways with significant truck/bus traffic should have 12 feet wide traffic lanes. For minimum lane widths, see Table 3 - 7 and Table 3 - 8. If additional lane width is required for bicycles, see Chapter 9.

C.7.b.2. Pavement Cross Slope (not in superelevation)

The selection of pavement cross slope should be a compromise between meeting the drainage requirements and providing for smooth vehicle operation. The recommended pavement cross slope is 0.02 feet per foot. When three lanes in each direction are necessary, the outside lane should have a cross slope of 0.03 feet per foot. The cross slope shall not be less than 0.015 feet per foot or greater than 0.04 feet per foot. The change in cross slope between adjacent through travel lanes should not exceed 0.04 feet per foot.

C.7.c. Shoulders

The primary functions of a shoulder are to provide emergency parking for disabled vehicles and an alternate path for vehicles during avoidance or other emergency maneuvers. In order to fulfill these functions satisfactorily, the shoulder should have adequate stability and surface characteristics. The design and construction of shoulders shall be in

accordance with the requirements given in CHAPTER 5 - PAVEMENT DESIGN, CONSTRUCTION AND MAINTENANCE.

Shoulders should be provided on all streets and highways incorporating open drainage. The absence of a contiguous emergency travel or storage lane is not only undesirable from a safety standpoint, but also is disadvantageous from an operations viewpoint. Disabled vehicles that must stop in a through lane impose a severe safety hazard and produce a dramatic reduction in traffic flow. Shoulders should be free of abrupt changes in slope, discontinuities, soft ground, or other hazards which would prevent the driver from retaining and regaining vehicle control.

Paved shoulders are recommended for added safety to the motorist, public transit and pedestrians, for accommodation of bicyclists, reduced shoulder maintenance costs, and improved drainage.

C.7.c.1. Shoulder Width

Since the function of the shoulders is to provide an emergency storage or travel path, the desirable width of all shoulders should be at least 10 feet in width. Where economic or practical constraints are severe, it is permissible, but not desirable, to reduce the shoulder width. Outside shoulders shall be provided on all streets and highways with open drainage and should be at least 6 feet wide. Facilities with a heavy traffic volume or a significant volume of truck traffic SHOULD have outside shoulders at least 8 feet wide. The width of outside shoulders for two-lane, two-way shoulders shall not be less than the values given in Table 3 - 8.

Median shoulders are desirable on all multi-lane, non-curb and gutter divided streets and highways. For shoulder widths on multi-lane divided highways see Table 3 - 9.

C.7.c.2. Shoulder Cross Slope

The shoulder serves as continuation of the drainage system, therefore, the shoulder cross slope should be somewhat greater than the adjacent travel lane. The cross slope of shoulders shall not be less than 0.03 feet per foot or greater than 0.08 feet per foot. For local subdivision type streets, a maximum cross slope of 0.12 feet per

foot may be used.

Whenever possible shoulders should be sloped away from the traffic lanes to aid in their drainage. The combination of shoulder cross slope and texture should be sufficient to promote rapid drainage and to avoid retention of surface water. The change in cross slope between a traffic lane and adjacent shoulder should not be greater than 0.07 feet per foot, except on local subdivision streets where the change in cross slope should not exceed 0.10 feet per foot. Shoulders on the outside of superelevated curves should be rounded (vertical curve) to avoid an excessive break in cross slope and to divert a portion of the drainage away from the adjacent travel lanes.

C.7.d. Sidewalks

The design of sidewalks is affected by many factors, including, but not limited to, pedestrian volume, roadway type, characteristics of vehicular traffic, and other design elements. CHAPTER 8 - PEDESTRIAN TRAFFIC of this Manual and the AASHTO - "Policy on Geometric Design," present the various factors that influence the design of sidewalks and other pedestrian facilities.

Sidewalks should be constructed in conjunction with new construction and major reconstruction in an urban area. As a general rule, sidewalks should be constructed on both sides of the roadway. Exceptions may be made where physical barriers (e.g., a canal paralleling one side of the roadway) would substantially reduce the expectation of pedestrian use of one side of the roadway. Also, if only one side is possible, sidewalks should be used in the same side of the road as such features as transit stops or other pedestrian generators.

The decision to construct a sidewalk in a rural area should be based on engineering judgment, after observation of existing pedestrian traffic and expectation of additional demand, should a sidewalk be made available.

The standard width of a sidewalk should be 5 feet when separated from the back of curb by a buffer strip. A 4 foot sidewalk may be considered when physical constraints exist and where necessary right of way is unavailable or prohibitively expensive. When sidewalks must be constructed adjacent to

the curb, the minimum width should be 6 feet. Sidewalks should be constructed as defined in this Manual - CHAPTER 8 - PEDESTRIAN TRAFFIC. In areas of high use, refer to Chapter 13 of the Highway Capacity Manual for calculation of appropriate width. As noted in the FDOT Bicycle Facilities Planning and Design Handbook, excessively wide sidewalks may not necessarily add to pedestrian and bicycle safety. Wide sidewalks may encourage higher speed bicycle use and can increase the potential for conflict with motor vehicles at intersections and driveways, as well as with pedestrians and fixed objects.

Cross slopes should be 2% and grades should not exceed 8%. Curb ramps should be provided at all intersections (Section 336.045 (3), Florida Statutes). For additional details, refer to the current Americans with Disabilities Act (ADA) Guidelines as described in the Federal Register.

Consideration shall be given to pedestrians in work zones and construction sites. In areas of high use, construction of temporary facilities should be considered.

C.7.e. Medians

Median separation of opposing traffic lanes provides a beneficial safety feature and should be used wherever feasible. Separation of the opposing traffic also reduces the problem of headlight glare, thus improving the safety and comfort for night driving. When sufficient width of medians is available, some landscaping is also possible.

The use of medians often aid in the provision of drainage for the roadway surface, particularly for highways with six or more traffic lanes. The median also provides a vehicle refuge area, improves the safety of pedestrian crossings, a logical location for left turn storage lanes, and the means for future addition of traffic lanes and mass transit. In many situations, the median strip aids in roadway delineation and the overall highway aesthetics.

Median separation is required on the following streets and highways:

- Freeways
- All streets and highways, rural and urban, with 4 or more travel lanes and with a design speed of 40 mph or greater

Median separation is desirable on all other multi-lane roadways to enhance pedestrian crossings.

The nature and degree of median separation required is dependent upon the design speed, traffic volume, adjacent land use, and the frequency of access. There are basically two approaches to median separation. The first is the use of horizontal separation of opposing lanes to reduce the probability of vehicles crossing the median into incoming traffic. The second method is to attempt to limit crossovers by introducing a positive median barrier structure.

In rural areas, the use of wide medians is not only aesthetically pleasing, but is often more economical than barriers. In urban areas where space and/or economic constraints are severe, the use of barriers is permitted to fulfill the requirements for median separation.

Uncurbed medians should be free of abrupt changes in slope, discontinuities, soft ground, or other hazards which would prevent the driver from retaining or regaining control of the vehicle. Consideration should be given to increasing the width and decreasing the slope of medians on horizontal curves. The requirements for a hazard free median environment are given in CHAPTER 4 - ROADSIDE DESIGN, and shall be followed in the design and construction of medians.

C.7.e.1. Type of Median

A wide, gently depressed median is the preferred design. This type allows a reasonable vehicle recovery area and aids in the drainage of the adjacent shoulders and travel lanes. Where space and drainage limitations are severe, narrower medians, flush with the roadway, or raised medians, are permitted. Raised medians should be used to support pedestrian crossings of multi-laned highways.

C.7.e.2. Median Width

The median width is defined as the horizontal distance between the inside pavement edges of the opposing roadways. The selection of the median width for a given type of roadway is primarily dependent on design speed and traffic volume. Since the probability of crossover accidents is decreased by increasing the separation, medians should be as wide as practicable. Median widths in excess of 30 feet to 35 feet reduce the problem of disabling headlight glare

from opposing traffic.

The minimum permitted widths of freeway medians are given in Table 3 - 10. Where the expected traffic volume is heavy, the widths should be increased over these minimum values. Median barriers shall be used on freeways when these minimum values are not attainable.

The minimum permitted median widths for multi-lane rural highways are given in Table 3 - 11. On urban streets, the median widths shall not be less than the values given in Table 3 - 11. Where median openings or access points are frequent, the median width should be increased.

The minimum median widths given in these Tables may have to be increased to meet the requirements for cross slopes, drainage, and turning movements (C.9 Intersection Design, this Chapter). The median area should also include adequate additional width to allow for expected additions of through lanes and left turn storage lanes. Where the median width is sufficient to produce essentially two separate, independent roadways, the left side of each roadway shall meet the requirements for roadside clear zone. Changes in the median width should be accomplished by gently flowing horizontal alignment of one or both of the separate roadways.

C.7.e.3. Median Slopes

A vehicle should be able to transverse a median without turning over and with sufficient smoothness to allow the driver a reasonable chance to control his vehicle. The transition between the median slope and the shoulder (or pavement) slope

should be smooth, gently rounded, and free from discontinuities.

The median cross slope should not be steeper than 1:6 (preferably not steeper than 1:10). The depth of depressed medians may be controlled by drainage requirements. Increasing the width of the median, rather than increasing the cross slope, is the proper method for developing the required median depth.

Longitudinal slopes (median profile parallel to the roadway) should be shallow and gently rounded at intersections of grade. The longitudinal slope, relative to the roadway slope, shall not exceed a ratio of 1:10 and preferably 1:20. The change in longitudinal slope shall not exceed 1:8 (change in grade of 12.5 %).

C.7.e.4. Median Barriers

The primary objective for placing a barrier structure in the median is to prevent vehicles from entering the opposing traffic stream, either accidentally or intentionally. Median barriers may also be used to reduce the glare produced by oncoming vehicle headlights. When selecting the type of barrier, care should be exercised to avoid headlight flicker through barriers.

The use of median barriers to reduce horizontal separation is permitted on facilities with substantially full control of access. Frequent openings in the barrier for intersections or crossovers expose the barrier end, which constitute severe hazard at locations with an inherently high accident potential and should be shielded. Median barriers may be considered for urban freeways and major arterials with controlled access.

Median barriers shall be used on controlled access facilities if the median width is less than the minimum permitted values given in Table 3 -10. The median barrier should not be placed closer than 10 feet from the inside pavement edge. Further requirements for median barriers are given in CHAPTER 4 - ROADSIDE DESIGN.

C.7.f. Roadside Clear Zone

The roadside clear zone is that area outside the traveled way available for use by errant vehicles. Vehicles frequently leave the traveled way during avoidance maneuvers, due to loss of control by the driver (e.g., falling asleep) or due to collisions with other vehicles. The primary function of the clear zone is to allow space and time for the driver to retain control of his vehicle and avoid or reduce the consequences of collision with roadside objects. This area also serves as an emergency refuge location for disabled vehicles.

The design of the roadway must also provide for adequate drainage of the roadway. Drainage swales within the clear zone should be gently rounded and free of discontinuities. Where large volumes of water must be carried, the approach should be to provide wide, rather than deep drainage channels. Side slopes and drainage swales that lie within the clear zone should be free of protruding drainage structures (CHAPTER 4 - ROADSIDE DESIGN, D.6.c. Culverts)

In the design of the roadside, the designer should consider the consequences of a vehicle leaving the traveled way at any location. It should always be the policy that protection of vehicles and occupants shall take priority over the protection of roadside objects. Further criteria and requirements for safe roadside design are given in CHAPTER 4 - ROADSIDE DESIGN.

C.7.f.1. Roadside Clear Zone Width

The clear zone width is defined as follows:

- Rural sections - measured from the edge of the outside motor vehicular travel way
- Urban sections - measured from the face of the curb

The minimum permitted widths are provided in Table 3 - 12. These are minimum values only and should be increased wherever practical.

In rural areas, it is desirable, and frequently economically feasible, to increase the width of the clear zone. Where traffic volumes and speeds are high, the width should be increased. The clear zone on the outside of horizontal curves should be increased due to the possibility of vehicles leaving the roadway at a steeper angle.

C.7.f.2. Roadside Slopes

The slopes of all roadsides should be as flat as possible to allow for a safe traversal by out of control vehicles. A slope of 1:4 or flatter should be used. The transition between the shoulder and adjacent side slope should be rounded and free from discontinuities. The adjacent side slope, within the clear zone, shall not be steeper than 1:3. The side slopes should be reduced flatter on the outside of horizontal curves.

Where roadside ditches or cuts require backslope, these slopes should not exceed 1:3 in steepness within the clear zone. The desirable backslope is 1:4. Ditch bottoms should be at least 4 feet wide and can be flat or gently rounded.

C.7.f.3. Criteria for Guardrail

If space and economic constraints are severe, it is permissible, but not desirable, to use guardrails in lieu of the requirements for width and slope of clear zone. Where the previously described requirements for clear zone are not met, guardrails (or other longitudinal barriers) should be considered. Guardrails should also be considered for protection of pedestrian pathways or protection from immovable roadside hazards.

The general policy to be followed is that guardrails should be used if impact with the guardrail is less likely or considered less severe than impact with roadside objects. Further requirements and design criteria for guardrails are given in CHAPTER 4 - ROADSIDE DESIGN.

C.7.g. Curbs

Curbs may be used to provide drainage control and to improve delineation of the roadway. Curbs are generally designed with a gutter to form a combination curb and gutter section. Curbs with nearly vertical faces are used along the outside edge of the roadway to discourage vehicles from leaving the roadway. In Florida, the standard curb of this type is 6 inches in height. These curbs are not to be used on facilities with design speeds greater than 45 mph.

C.7.h. Parking

When on-street parking is to be an element of design, parallel parking should be considered. Under certain circumstances, angle parking is an allowable form of street parking. The type of on-street parking selected should depend on the specific function and width of the street, the adjacent land use, traffic volume, as well as existing and anticipated traffic operations.

It can generally be stated that on-street parking decreases through capacity, impedes traffic flow, and increases crash potential. However, where parking is needed, and adequate off-street parking facilities are not available or feasible, on-street parking may be necessary.

C.7.i. Right of Way

The acquisition of sufficient right of way is necessary in order to provide space for a safe street or highway. The width of the right of way required depends on the design of the roadway, the arrangement of bridges, underpasses and other structures, and the need for cuts or fills. The right of way acquired should be sufficient to:

- Allow development of the full cross section, including adequate medians and roadside clear zones. Determination of the necessary width requires that adequate consideration also be given to the accommodation of utility poles beyond the clear zone.
- Provide for the layout of safe intersections, interchanges, and other access points
- Allow for adequate sight distance at all points, particularly on horizontal curves, at an intersection, and other access points
- Provide, where appropriate, transit bus bays, additional buffer zones to improve roadside safety, noise attenuation, and the overall aesthetics of the street or highway
- Provide adequate space for placement of pedestrian and bicycle facilities, including curb ramps, storage turning areas, and transit shelters, where applicable
- Allow for future lane additions, increases in cross section, or other improvement. Frontage roads should also be considered in the ultimate development of many high volume facilities.
- Provide for irrigation and treatment of stormwater runoff
- Provide for construction of future grade separations or other intersection improvements at selected crossroads
- Provide corner cuts for upstream corner crossing drainage systems and placement of poles, boxes, and other visual screens out of the critical sight triangle

The acquisition of wide rights of way is costly, but it is necessary to allow for the construction and future improvement of safe streets and highways. The minimum right of way should be at least 50 feet for all two lane roads. For pre-existing conditions, when the existing right of way is less than 50 feet, efforts should be made to acquire the necessary right of way.

Local cul-de-sac and dead end streets having an ADT of less than 250, and a length of 600 feet or less, may utilize a right of way of less than 50 feet, if all elements of the typical section meet the standards included in this Manual.

The right of way for frontage roads may be reduced depending on the typical section requirements and the ability to share right of way with the adjacent highway facility.

C.7.j. Changes in Typical Section

C.7.j.1. General Criteria

Changes in cross section should be avoided. When changes in widths, slopes, or other elements are necessary, they should be affected in a smooth, gradual fashion.

C.7.j.2. Lane Deletions and Additions

The addition or deletion of traffic lanes should be undertaken on tangent sections of roadways. The approach to lane deletions and additions should have ample advance warning and sight distance.

The termination of lanes (including auxiliary lanes) shall meet the general requirements for merging lanes.

Where multiple lanes are intermittently provided on two-lane, two-way highways, median separation should be provided. Advance warnings in the form of multiple signs or pavement markings should be provided.

C.7.j.3. Special Use Lanes

To increase the efficiency and separation of different vehicle movements, special use lanes, such as bike lanes and bus lanes, should be considered. These lanes are often an enhancement to

corridor safety and increase the horizontal clearance to roadside above-ground fixed objects.

C.7.j.4. Structures

The pavement, median, and shoulder width, and sidewalks should be carried across structures such as bridges and box culverts. Shoulder widths for multi-lane rural divided highway bridges may be reduced as shown in Table 3 - 9. The designer should evaluate the economic practicality of utilizing dual versus single bridges for roadway sections incorporating wide medians.

The minimum roadway width for bridges on urban streets with curb and gutter shall be the same as the curb-to-curb width of the approach roadway. Sidewalks on the approaches should be carried across all structures. Curbed sidewalks should not be used adjacent to traffic lanes when design speeds exceed 45 mph. When the bridge rail (barrier wall) is placed between the traffic and sidewalk, it should be offset a minimum distance of 2½ feet from the edge of the travel lane, wide curb lane or bicycle lane. For long (500 feet or greater), and/or high level bridges, it is desirable to provide an offset distance that will accommodate a disabled vehicle. The transition from the bridge to the adjacent roadway section may be made by dropping the curb at the first intersection or well in advance of the traffic barrier, or reducing the curb in front of the barrier to a low mountable curb with a gently sloped traffic face.

C.7.j.4.(a). Horizontal Clearance

Supports for bridges, barriers, or other structures should be placed at or beyond the required shoulder. Where possible, these structures should be located outside of the required clear zone.

C.7.j.4.(b). Vertical Clearance

Vertical clearance should be adequate for the type of expected traffic. Freeways and major arterials shall have a vertical clearance of at least 16 feet. Other streets and highways should have a clearance of 16 feet unless the provision of a reduced clearance is fully justified by a specific analysis of the situation. Provision for additional clearance (3 inches to 6 inches) is recommended to allow for future resurfacing.

C.7.j.4.(c). End Treatment

The termini of guardrails, bridge railings, and abutments, and other structures should be constructed to protect vehicles and their occupants from serious impact. Requirements for end treatment of structures are given in CHAPTER 4 - ROADSIDE DESIGN.

C.8. Access Control

All new facilities (and existing when possible) should have some degree of access control, since each point of access produces a traffic conflict. The control of access is one of the most effective, efficient, and economical methods for improving the capacity and safety characteristics of streets and highways. The reduction of the frequency of access points and the restriction of turning and crossing maneuvers, which should be primary objectives, is accomplished more effectively by the design of the roadway geometry than by the use of traffic control devices. Design criteria for access points are presented under the general requirements for intersection design.

C.8.a. Justification

The justification for control of access should be based on several factors, including safety, capacity, economics, and aesthetics.

C.8.b. General Criteria

C.8.b.1. Location of Access Points

All access locations should have adequate sight distance available for the safe execution of entrance, exit, and crossing maneuvers.

Locations of access points near structures, decision points, or the termination of highway lighting should be avoided.

Driveways should not be placed near intersections or other points that would tend to produce traffic conflict.

C.8.b.2. Spacing of Access Points

The spacing of access points should be adequate to prevent conflict or mutual interference of traffic flow.

Separation of entrance and exit ramps should be sufficient to provide adequate distance for required weaving maneuvers.

Adequate spacing between access and decision points is necessary to avoid burdening the driver with the need for rapid decisions or maneuvers.

Frequent median openings should be avoided.

The use of a frontage road or other auxiliary roadways is recommended on minor arterials and higher classifications where the need for direct driveway or minor road access is frequent.

C.8.b.3. Restrictions of Maneuvers

Where feasible, the number and type of permitted maneuvers (crossing, turning slowing, etc.) should be restricted.

The restriction of crossing maneuvers may be accomplished by the use of grade separations and continuous raised medians.

The restrictions of left turns is achieved most effectively by continuous medians.

Channelization should be considered for the purposes of guiding traffic flow and reducing vehicle conflicts.

C.8.b.4. Turn Lanes

Deceleration lanes for right turns exits (and left turns, where permitted) should be provided on all high speed facilities. These turn lanes should not be excessive or continuous, since they complicate pedestrian crossings and bicycle/motor vehicle movements.

Storage (or deceleration lanes) to protect turning vehicles should be provided, particularly where turning volumes are significant.

Acceleration lanes are desirable for entrance maneuvers onto high speed streets and highways.

Special consideration should be given to the provisions for deceleration, acceleration, and storage lanes in commercial or industrial areas with significant truck/bus traffic.

C.8.b.5. Grade Separation

Grade separation interchange design should be considered for junctions of major arterial streets and highways.

Grade separation (or an interchange) should be utilized when the expected traffic volume exceeds the intersection capacity.

Grade separation should be considered to eliminate conflict or long waiting periods at potentially hazardous intersections.

C.8.b.6. Roundabouts (Small Circular Islands)

Roundabouts are another tool for the designer to consider in intersection design. These have been used extensively in Europe and Australia. The true roundabout is characterized by the following:

- A central island of sufficient diameter (150 feet or less) to accommodate vehicle tracking and to provide sufficient deflection to promote lower speeds
- Entry is by gap acceptance through a yield condition at all legs
- Speeds through the intersection are 25 mph or less
- Generally, less right of way is required than for traditional intersection design

The use of roundabouts should be determined by a detailed documented intersection analysis, as is also necessary for other type designs.

C.8.c. Control for All Limited Access Highways

Entrances and exits on the right side only are highly desirable for all limited access highways. Acceleration and deceleration lanes are mandatory. Intersections shall be accomplished by grade separation (interchange) and should be restricted to connect with arterials or collector roads.

The control of access on freeways should conform to the requirements given in Table 3 - 13. The spacing of exits and entrances should be increased wherever possible to reduce conflicts. Safety and capacity characteristics are improved by restricting the number and increasing the spacing of access points.

C.8.d. Control of Urban Streets

The design and construction of urban, as well as rural, highways should be governed by the general criteria for access control previously outlined. In addition, the design of urban streets should be in accordance with the criteria listed below:

- The general layout of local and collector streets should follow a branching network, rather than a highly interconnected grid pattern.
- The street network should be designed to reduce, consistent with origin/destination requirements, the number of crossing and left turn maneuvers.
- The design of the street layout should be predicated upon reducing the need for traffic signals.
- The use of a public street or highway as an integral part of the internal circulation pattern for commercial property should be discouraged.
- The number of driveway access points should be restricted as much as possible through areas of strip development.
- Special consideration should be given to providing turn lanes (auxiliary lane for turning maneuvers) where the total volume or truck/bus volume is high.
- Major traffic generators may be exempt from the restrictions on driveway access if the access point is designed as a normal intersection adequate to handle the expected traffic volume.

These are minimum requirements only; it is generally desirable to use more stringent criteria for control of access.

C.8.e. Control for Rural Highways

The design of rural highways should be in accordance with the general criteria for access control for urban streets. The use of acceleration and deceleration lanes on all high-speed highways, particularly if truck and bus traffic is significant, is strongly recommended.

C.8.f. Land Development

It should be the policy of each agency with responsibility for highway design, construction, or maintenance to promote close liaison with utility, lawmaking, zoning, building, and planning agencies. Cooperation should be solicited in the formulation of laws, regulations, and master plans for land use, zoning, and highway construction. Further requirements and criteria for access control and land use relationships are given in CHAPTER 2 - LAND DEVELOPMENT.

C.9. Intersection Design

Intersections increase traffic conflicts and the demands on the driver, and are inherently hazardous locations. The design of an intersection should be predicated on reducing motor vehicle, bicycle, and pedestrian conflicts, minimizing the confusion and demands on the driver for rapid and/or complex decisions, and providing for smooth traffic flow. The location and spacing of intersections should follow the requirements presented in C.8 Access Control, this Chapter. Intersections should be designed to minimize time and distance of all who pass through or turn at an intersection.

The additional effort and expense required to provide a high quality intersection is justified by the corresponding safety benefits. The overall reduction in accident potential derived from a given expenditure for intersection improvements is generally much greater than the same expenditure for improvements along an open roadway. Poor intersections also reduce the traffic capacity, thereby limiting the overall capacity and economic value of the street or highway.

The requirements and design criteria contained in this section are applicable to all driveways, intersections, and interchanges. All entrances to, exits from, or interconnections between streets and highways are subject to these design standards.

C.9.a. General Criteria

The layout of a given intersection may be influenced by constraints unique to a particular location or situation. The design shall conform to sound principles and criteria for safe intersections. The general criteria include the following:

- The layout of the intersection should be as simple as is practicable. Complex intersections which tend to confuse and distract the driver, produce inefficient and hazardous operations.
- The intersection arrangement should not require the driver to make rapid or complex decisions.
- The layout of the intersection should be clear and understandable so a proliferation

of signs, signals, or markings is not required to adequately inform and direct the driver.
- The design of intersections, particularly along a given street or highway, should be as consistent as possible.
- The approach roadways should be free from steep grades and sharp horizontal or vertical curves.
- Intersections with driveways or other roadways should be as close to right angle as possible.
- Adequate sight distance should be provided to present the driver a clear view of the intersection and to allow for safe execution of crossing and turning maneuvers.
- The design of all intersection elements should be consistent with the design speeds of the approach roadways.
- The intersection layout and channelization should encourage smooth flow and discourage wrong way movements.
- Special attention should be directed toward the provision of safe roadside clear zones.
- The provision of special turn lanes should be in conformance with the criteria set forth in C.8 Access Control, this Chapter.

- The requirements for bicycle and pedestrian movements should receive special consideration.

C.9.b. Sight Distance

Inadequate sight distance is a contributing factor in the cause of a large percentage of intersection accidents. The provision of adequate sight distance at intersections is absolutely essential and should receive a high priority in the design process.

C.9.b.1. General Criteria

General criteria to be followed in the provision of sight distance include the following:

- Sight distance exceeding the minimum stopping sight distance should be provided on the approach to all intersections (entrances, exits, stop signs, traffic signals, and intersecting roadways). The use of proper approach geometry free from sharp horizontal and vertical curvature will normally allow for adequate sight distance.
- The approaches to exits or intersections (including turn, storage, and deceleration lanes) should have adequate sight distance to allow for safe speed and lane change maneuvers.
- Adequate sight distance should be provided on the through roadway approach to entrances (from acceleration or merge lanes, stop or yield signs, driveways or traffic signals) to provide capabilities for defensive driving. This lateral sight distance should include as much length of the entering lane or intersecting roadway as is feasible. A clear view of entering vehicles is necessary to allow through traffic to aid merging maneuvers and to avoid vehicles which have "run" or appear to have the intention of running stop signs or traffic signals.
- Approaches to school or pedestrian crossings and crosswalks should have sight distances exceeding the minimum values. This should also include a clear view of the adjacent pedestrian pathways or multi-use trails.

- Sight distance in both directions should be provided for all entering roadways intersecting roadways and driveways) to allow entering vehicles to avoid through traffic. Refer to Fig. 3 - 11.
- Safe stopping sight distances shall be provided throughout all intersections, including turn lanes, speed change lanes, and turning roadways.
- The use of lighting (CHAPTER 6 - ROADWAY LIGHTING) should be considered to improve intersection sight distance for night driving.

C.9.b.2. Obstructions to Sight Distance

The provisions for sight distance are limited by the highway geometry and the nature and development of the area adjacent to the roadway. Where line of sight is limited by vertical curvature or obstructions, stopping sight distance shall be based on the eye height of 3.50 feet and an object height of 0.50 feet. At exits or other locations where the driver may be uncertain as to the roadway alignment, a clear view of the pavement surface should be provided. At locations requiring a clear view of other vehicles or pedestrians for the safe execution of crossing or entrance maneuvers, the sight distance should be based on a driver's eye height of 3.50 feet and an object height of 3.00 feet (preferably 1.50 feet). The height of eye for truck traffic may be increased for determination of line of sight obstructions for intersection maneuvers. Obstructions to sight distance at intersections include the following:

- Any property not under the highway agency's jurisdiction, through direct ownership or other regulations, should be considered as an area of potential sight distance obstruction. Based on the degree of obstruction, the property should be considered for acquisition by deed or easement.
- Areas which contain vegetation (trees, shrubbery, grass, etc.) that cannot easily be trimmed or removed by regular maintenance activity should be considered as sight obstructions.
- Parking lanes shall be considered as obstructions to line of

sight. Parking shall be prohibited within clear areas required for sight distance at intersections.

- Large (or numerous) poles or support structures for lighting, signs, signals, or other purposes that significantly reduce the field of vision within the limits of clear sight shown in Figure 3-11 may constitute sight obstructions. Potential sight obstructions created by poles, supports, and signs near intersections should be carefully investigated.

In order to ensure the provision for adequate intersection sight distance, on-site inspections should be conducted before and after construction, including placement of signs, lighting, guardrails, or other objects and how they impact intersection sight distance.

C.9.b.3. Stopping Sight Distance

The provision for safe stopping sight distance at intersections and on turning roadways is even more critical than on open roadways. Vehicles are more likely to be traveling in excess of the design or posted speed and drivers are frequently distracted from maintaining a continuous view of the upcoming roadway.

C.9.b.3.(a). Approach to Stops

The approach to stop signs, yield signs, or traffic signals should be provided with a sight distance no less than values given in Table 3-14. These values are applicable for any street, highway, or turning roadway. The driver should, at this required distance, have a clear view of the intersecting roadway, as well as the sign or traffic signal.

Where the approach roadway is on a grade or vertical curve, the sight distance should be no less than the values shown in Figure 3-7. In any situation where it is feasible, sight distances exceeding those should be provided. This is desirable to allow for more gradual stopping maneuvers and to reduce the likelihood of vehicles running through stop signs or signals. Advance warnings for stop signs are desirable.

C.9.b.3.(b). On Turning Roads

The required stopping sight distance at any location on a turning roadway (loop, exit, etc.) shall be based on the design speed at that

point. Ample sight distance should be provided since the driver is burdened with negotiating a curved travel path and the available friction factor for stopping has been reduced by the roadway curvature. The minimum sight distance values are given in Table 3 - 14 or Figure 3 - 7. Due to the inability of vehicle headlights to adequately illuminate a sharply curved travel path, roadway lighting should be considered for turning roadways.

C.9.b.4. Sight Distance for Intersection Maneuvers (Non-signalized Intersections)

C.9.b.4.(a). Crossing Maneuver

The sight distance required for the safe execution of a crossing maneuver is dependent on the acceleration capabilities of the vehicle, the crossing distance, and the design speed of the street or highway to be crossed. The minimum required sight distance in both directions (measured from the entering roadway centerline) for various classes of vehicles is given in Figures 3 - 8, 3 - 9, and 3 - 10. This minimum sight distance should be provided for a given vehicle class if it constitutes 5 percent or more of the total crossing traffic or experiences 30 or more crossings per day.

The crossing distance (W) shown in Figure 3 - 11, shall include the total width of roadway to be crossed, plus the vehicle offset from the nearest motor vehicle travel lane edge, plus the vehicle length. The roadway width shall include the median as well as all through travel lanes. The position of the vehicle shall be assumed to be at least 10 feet from the nearest travel lane (vehicle offset). Where the median width is at least 5 feet wider than the design vehicle length (Table 3 - 2), the crossing may be assumed to take place in two separate maneuvers.

On median separated roadways, sight distance to the left may be based on the distance (W) required to clear the first set of travel lanes.

The setback (Figure 3 - 11) required for sight distance shall be at least 5 feet greater than the vehicle offset. This will result in a total minimum setback distance of 15 feet. To the extent practical, there shall be nothing within the clear area for sight distance shown in Figure 3 - 11 that would prohibit the ability

to see on-coming vehicles. At intersections with traffic signals, it is desirable to provide this same sight distance capability.

The minimum sight distance obtained from Figures 3 - 8, 3 - 9, and 3 - 10, should only be used for level conditions. The time required to cross the major highway is materially affected by the grade of the crossing. Normally, the grade across an intersection is so small it need not be considered, but when curvature of the major road requires the use of superelevation, the grade across it may be significant. In this case, the sight distance along the major road should be greater. Figure 3 - 12 should be used to obtain the minimum sight distance for crossing when grade is considered.

When executing a crossing or turning maneuver after stopping at a stop sign, stop bar, or crosswalk as required in Section 316.123, Florida Statutes, it is assumed that the vehicle will move slowly forward to obtain sight distance (without intruding into the crossing travel lane) stopping a second time as necessary.

C.9.b.4.(b). Left Turn Crossings

Sight distance for left turn crossings shall be no less than the values given in Figures 3 - 8, 3 - 9, and 3 - 10. This clear view shall include the cross section of the opposing traffic lanes which the vehicle must cross in executing the left turn. The crossing distance (W) shall include the pavement width of the opposing through lanes, plus the vehicle offset, plus the length of the crossing vehicle. This required sight distance should be provided at intersections with traffic signals as well as exits to stop-controlled roadways.

C.9.c. Auxiliary Lanes

Auxiliary lanes are desirable for the safe execution of speed change maneuvers (acceleration and deceleration) and for the storage and protection of turning vehicles. Auxiliary lanes for exit or entrance turning maneuvers shall be provided in accordance with the requirements set forth in C.8 Access Control, this Chapter. The pavement width and cross slopes of auxiliary lanes should meet the minimum requirements for all travel lanes. Clear zones are less, since measured from through lanes, so clear area may be less from auxiliary lanes.

C.9.c.1. Merging Maneuvers

Merging maneuvers occur at the termination of climbing lanes, lane drops, entrance acceleration, and turning lanes. The location provided for this merging maneuver should, where possible, be on a tangent section of the roadway and should be of sufficient length to allow for a smooth, safe transition. The provision of ample distance for merging is essential to allow the driver time to find an acceptable gap in the through traffic and then execute a safe merging maneuver. It is recommended that a merging taper be on a 1:50 transition, but in no case shall the length be less than set forth in Table 3 - 15. The termination of this lane should

be clearly visible from both the merging and through lane and should correspond to the general configuration shown in Figure 3 - 13. Advance warning of the merging lane termination should be provided. Lane drops shall be marked to provide a safe merging maneuver.

C.9.c.2. Acceleration Lanes

Acceleration lanes are required for all entrances to freeway ramps. Acceleration lanes are recommended for entrances to all high speed (design speed greater than 50 mph) facilities and locations with heavy traffic volumes. Any street or highway with a large percentage of truck traffic should be considered for acceleration lanes at entrances.

The distance required for an acceleration maneuver is dependent on the vehicle acceleration capabilities, the grade, the initial entrance speed, and the final speed at the termination of the maneuver. The distances required for acceleration on level roadways for passenger cars are given in Table 3 -16. Where acceleration occurs on a grade, the required distance is obtained by using Tables 3 -16 and 3 -17.

The final speed at the end of the acceleration lane, should, desirably, be assumed as the design speed of the through roadway. The length of acceleration lane provided should be at least as long as the distance required for acceleration between the initial and final speeds. Due to the uncertainties regarding vehicle capabilities and driver behavior, additional length is desirable. The acceleration lane should be followed by a merging taper (similar to Figure 3 - 13), not less than that length set forth in Table 3 - 15. The termination of acceleration lanes should conform to the general configuration shown for merging lanes in Figure 3 - 13. Recommended acceleration lanes for freeway entrance terminals are given in Table 3 - 19.

C.9.c.3. Exit Lanes

Auxiliary lanes for exiting maneuvers provide space outside the through lanes for protection and storage of decelerating vehicles exiting the facility.

- Deceleration Lanes - The primary function of deceleration lanes is to provide a safe travel path for vehicles decelerating from the operating speed on the through lanes. Deceleration lanes are required for all freeway exits and are desirable on all high speed (design speed greater than 50 mph) streets and highways.

The distance required for deceleration of passenger cars is given in Table 3 - 16.

The required distance for deceleration on grades is given in Tables 3 - 16 and 3 -17.

The length of deceleration lanes shall be no less than the values obtained from Tables 3 - 16 and 3 - 17, and should be increased wherever feasible. The initial speed should, desirably, be taken as the design speed of the highway. The final speed should be the design speed at the exit (e.g., a turning roadway) or zero, if the deceleration lane terminates at a stop or traffic signal. A reduction in the final speed to be used is particularly important if the exit traffic volume is high, since the speed of these vehicles may be significantly reduced.

The entrance to deceleration (and climbing) lanes should conform to the general configuration shown in Figure 3 - 14. The initial length of straight taper, shown in Table 3 - 16, may be utilized as a portion of the total required deceleration distance. The pavement surface of the deceleration lane should be clearly visible to approaching traffic, so drivers are aware of the maneuvers required. Recommended deceleration lanes for exit terminals are given in Table 3 - 18.

- Storage Lanes - Where exit lanes are required (C.8 Access Control, this Chapter), or desirable on low speed streets and highways, storage lanes may be used in place of or in conjunction with deceleration lanes. Storage lanes should be used on all facilities. Although the primary function of storage

lanes is to provide protection and storage for turning vehicles, it is desirable to provide sufficient length to allow for deceleration capabilities. Storage lanes should conform to the general configuration shown in Figure 3 - 15.

At unsignalized intersections, the storage length, exclusive of taper, may be based on the number of turning vehicles which are likely to arrive in an average two minute period within the peak hour (storage in feet = $2 \times 25/60 \times$ number of turning vehicles per hour). The length of storage lanes for unsignalized intersections may be obtained from the table in Figure 3 - 1 5. The full width portion of storage lanes should, where possible, be increased to allow for expected storage of vehicles (Table 3 - 2 for vehicle lengths). As a minimum requirement, storage for at least two passenger cars (40 - 50 feet) should be provided.

On arterial streets (design speed 45 mph or less), tapers preceding storage lanes and approaching intersections at grade may be shorter than those given in Table 3 - 16 (AASHTO for recommended lengths).

C.9.d. Turning Roadways

The design and construction of turning roadways shall meet the same general requirements for through roadways, except for the specific requirements given in the subsequent sections.

C.9.d.1. Design Speed

Lanes for turning movements at grade intersections may, where justified, be based on a design speed as low as 10 mph. Turning roadways with design speeds in excess of 40 mph, shall be designed in accordance with the requirements for through roadways.

A variable design speed may be used to establish cross section and alignment criteria for turning roadways that will experience acceleration and deceleration maneuvers.

C.9.d.2. Horizontal Alignment

- Curvature - The minimum permitted radii (maximum degree) of curvature for various values of superelevation are given in Table 3-22. These should be considered as minimum values only and the radius of curvature should be increased wherever

feasible. Further information contained in AASHTO - "A Policy on Geometric Design of Highways and Streets" - 1990, should also be considered.

- Superelevation Transition - Minimum superelevation transition (runoff) rates (maximum relative gradients) are given in Tables 3-23 and 3-24. Other information given in AASHTO - "A Policy on Geometric Design of Highways and Streets" - 1990, should also be considered.

C.9.d.3. Vertical Alignment

Grades on turning roadways should be as flat as practical and long vertical curves should be used wherever feasible. The length of vertical curves shall be no less than necessary to provide minimum stopping sight distance. Minimum stopping sight distance values are given in Table 3-14. For additional guidance on vertical alignment for turning roadways, see AASHTO - "A Policy on Geometric Design of Highways and Streets" - 1990.

C.9.d.4. Cross Section Elements

- Number of Lanes - One-way turning roadways are often limited to a single travel lane. In this case, the total width of the roadway shall be sufficient to allow traffic to pass a disabled vehicle. Two-way, undivided turning roadways should be avoided. Medians or barriers should be utilized to separate opposing traffic on turning roadways.
- Travel Lanes - The width of all travel lanes should be sufficient to accommodate (with adequate clearances) the turning movements of the expected types of vehicles. The minimum required lane widths for turning roadways are given in Table 3-21. Changes in lane widths should be gradual and should be accomplished in coordination with adequate transitions in horizontal curvature.
- Shoulders - On one-lane turning roadways, serving expressways and other principal arterials (e.g., loops, ramps), the right hand shoulder should be at least 6 feet wide. The left hand shoulder should be at least 6 feet wide in all cases. On two-lane, one-way roadways, both shoulders should be at least 6 feet wide. Where guardrails or other barriers are used, they

should be placed at least 8 feet from edge of travel lane. Guardrails should be placed 2 feet outside the normal shoulder width.

- Clear Zones - Turning roadways should, as a minimum, meet all open highway criteria for clear zones on both sides of the roadway. The areas on the outside of curves should be wider and more gently sloped than the minimum values for open highways. Guardrails or similar barriers shall be used if the minimum width and slope requirements cannot be obtained.

Further criteria and requirements for roadway design are given in CHAPTER 4 - ROADSIDE DESIGN.

C.9.e. At Grade Intersections

C.9.e.1. Turning Radii

Where right turns from through or turn lanes will be negotiated at low speeds (less than 10 mph), the minimum turning capabilities of the vehicle may govern the design. It is desirable that the turning radius and the required lane width be provided in accordance with the criteria for turning roadways. The radius of the inside pavement edge should, however, be sufficient to allow the expected vehicles to negotiate the turn without encroaching the shoulder or adjacent travel lanes.

Where turning roadway criteria are not used, the radius of the inside pavement edge should be no less than 25 feet. The use of three-centered compound curves is also a reasonable practice to allow for transition into and out of the curve. The recommended radii and arrangement of compound curves instead of a single simple curve is given in AASHTO - "A Policy on Geometric Design of Highways and Streets" - 1990.

C.9.e.2. Cross Section Correlation

The correlation of the cross section of two intersecting roadways is frequently difficult. A careful analysis should be conducted to ensure changes in slope are not excessive and adequate drainage is provided. At stop-controlled intersections, the through roadway cross section should be carried through the intersection without interruption. Minor roadways should approach the intersection at a slightly reduced elevation so main highway cross section is not disturbed. At

signalized intersections, it is sometimes necessary to remove part of the crown in order to avoid an undesirable hump in one roadway.

Intersections of grade or cross slope should be gently rounded to improve vehicle operation. Pavement generally should be sloped toward the intersection corners to provide superelevation for turning maneuvers and to promote proper drainage.

Where islands are used for channelization, the width of travel lanes for turning movements shall be no less than the widths recommended by AASHTO.

C.9.e.3. Median Openings

Median openings should be restricted in accordance with the requirements presented in C.8 Access Control, this Chapter. Where a median opening is required, the length of the opening shall be no less than 40 feet. Median curbs should be terminated gradually without the exposure of abrupt curb ends. The termination requirements are given in CHAPTER 4 - ROADSIDE DESIGN.

C.9.e.4. Channelization

Channelization of at grade intersections is the regulation or separation of conflicting movements into definite travel paths by islands, markings, or other means, to promote safe, orderly traffic flow. The major objective of channelization is to clearly define the appropriate paths of travel and thus assist in the prevention of vehicles deviating excessively or making wrong maneuvers. Channelization may be used effectively to define the proper path for exits, entrances, and intersection turning movements. The methods used for channelization should be as simple as possible and consistent in nature. The channelized intersection should appear open and natural to the approaching driver. Channelization should be informative rather than restrictive in nature.

The use of low easily-mounted curbs and flush medians and islands can provide adequate delineation in most cases. Island should be clearly visible and, in general, should not be smaller than 100 square feet in area. The use of small and/or numerous islands should be avoided.

Pavement markings are a useful and effective tool for providing delineation and channelization in an informative rather than restrictive

fashion. The layout of all traffic control devices should be closely coordinated with the design of all channelization.

C.9.f. Driveways

Direct driveway access to arterials and major collectors should be discouraged. All turnouts to adjacent property should be designed so vehicles can enter or leave from auxiliary traffic lanes.

Driveways from major traffic generators (greater than 400 vpd), or those with significant truck/bus traffic, should be designed as normal intersections.

C.9.g. Interchanges

The design of interchanges for the intersection of a freeway with a major highway, collector/distributor road or other freeway is a complex problem. The location and spacing of intersections should follow the requirements presented in C.8 Access Control, this Chapter. The design of interchanges shall follow the general intersection requirements for deceleration, acceleration, merging maneuvers, turning roadways, and sight distance.

Interchanges, particularly along a given freeway, should be reasonably consistent in their design. A basic principle in the design should be to develop simple open interchanges that are easily traversed and understandable to the driver. Complex interchanges with a profusion of possible travel paths are confusing and hazardous to the motorist and are generally inefficient.

Intersections with minor highway or collector/distributor roads may be accomplished by simple diamond interchanges. The intersection of exit and entrance ramps with the crossroad shall meet all intersection requirements.

The design of freeway exits should conform to the general configurations given in Table 3 - 18. Exits should be on the right and should be placed on horizontal curves. Where deceleration on an exit loop is required, the deceleration alignment should be designed so the driver receives adequate warning of the approaching increase in curvature. This is best accomplished by gradually increasing the curvature and the resulting centrifugal force. This increasing centrifugal force provides warning to the driver that he must slow down. A clear view of the exit loop should also be provided. The length of deceleration shall be no less than the values shown in Table 3 - 18.

Entrances to freeways should be designed in accordance with the general configurations shown below Table 3 - 19. Special care should be taken to

ensure vehicles entering from loops are not directed across through travel lanes. The entering roadway should be brought parallel (or nearly so) to the through lanes before entry is permitted. Where acceleration is required, the distances shown in Table 3 - 19 shall, as a minimum, be provided. Exits and entrances to all high speed facilities (design speed greater than 50 mph), should, where feasible, be designed in accordance with Tables 3 - 18 and 3 - 19. The lengths obtained from Tables 3 - 18 and 3 - 19 should be adjusted for grade by using the ratios in Table 3 - 17.

The selection of the type and exact design details of a particular interchange requires considerable study and thought. The guidelines and design details given in AASHTO "A Policy on Geometric Design of Highways and Streets" - 1990, should generally be considered as minimum criteria.

C.9.h. Clear Zone

The provisions of ample clear zone or proper redirection of energy absorbing devices is particularly important at intersections. Every effort should be made to open up the area around the intersection to provide adequate clear zone for vehicles which have left the traveled way. Drivers frequently leave the proper travel path due to unsuccessful turning maneuvers or due to the necessity for emergency avoidance maneuvers. Vehicles also leave the roadway after intersection collisions and roadside objects should be removed to reduce the probability of second impacts. The roadside areas at all intersections and interchanges should be contoured to provide shallow slopes and gentle changes in grade.

The roadside clear zone of intersecting roadways, should be carried throughout intersections with no discontinuities or interruptions. Poles and support structures for lights, signs, and signals should not be placed in medians or within the roadside clear zone.

The design of guardrails or other barriers should receive particular attention at intersections. Impact attenuators should be used in all gore and other areas where structures cannot be removed. Barrier curbs should not be used in intersections.

Particular attention should be given to the protection of pedestrians in intersection areas - CHAPTER 8 - PEDESTRIAN TRAFFIC. Further criteria and requirements for clear zone and protection devices at intersections are given in CHAPTER 4 - ROADSIDE DESIGN.

C.10. Other Design Factors

C.10.a. Pedestrian Facilities

The layout and design of the highway network should include provisions for pedestrian traffic in urban areas. All pedestrian crossings and pathways within the highway right of way should be considered and designed as an integral part of any street or urban highway. Design shall be in compliance with the Americans With Disabilities Act (ADA).

C.10.a.1 Policy and Objectives - New Facilities

The planning and design of new streets and urban highways shall include provisions for the safe orderly movement of pedestrian traffic. Provisions for pedestrian travel outside of the highway right of way should be considered.

The overall objective is to provide a safe, secure, continuous, convenient and comfortable trip continuity and access environment for pedestrian traffic.

C.10.a.2 Accessibility Requirements

Pedestrian facilities, such as walkways and sidewalks, must be designed to accommodate physically disabled persons whose mobility is dependent on wheelchairs and other devices. Note: Design shall be in compliance with the Florida Accessibility Code For Building Construction (Rule 9B-7.0042). Complete design criteria can be found in this publication.

C.10.a.3 Sidewalks

Sidewalks should provide a safe, comfortable space for pedestrians. The width of sidewalks is dependent upon the roadside environment; volume of pedestrians, the presence of businesses, schools, parks and other pedestrian attractors. The minimum width for sidewalks is 4 feet. Where sidewalks are placed adjacent to the curb, the walkway widths should be approximately 2 feet wider. To ensure compliance with the Florida Accessibility Code For Building Construction sidewalk design shall meet the following criteria:

Minimum clear width	-	36 inches ^{1,2}
Maximum cross slope	-	0.02%

Maximum slope - 1:20³

¹ Sidewalks less than 60 inches wide must have passing spaces at least 60 inches by 60 inches at intervals not to exceed 200 feet.

² The minimum clear width may be reduced to 32 inches for a short distance. This distance must be less than 24 inches long and separated by 5 foot long sections with 36 inches of clear width.

³ Slopes greater than 1:20 are considered ramps and must be designed as such.

Sidewalks 5 feet wide or wider will provide for two adults to walk comfortably side by side.

C.10.a.4 Curb Ramps

In areas with sidewalks, curb ramps must be incorporated at locations where crosswalks adjoin the sidewalks. The basic ramp type and design application depends on the geometric characteristics of the intersection or other crossing location.

Ramp width shall be a minimum of 3 feet with 1:12 curb transitions on each side when pedestrians must walk across the ramp. Ramp slopes shall not exceed 1:12 and shall have a slip resistant surface texture. Ramp widths equal to crosswalk widths are encouraged.

Curb ramps at marked crossings shall be wholly contained within the crosswalk markings excluding any flared sides.

If diagonal ramps must be used, any returned curbs or other well-defined edges shall be parallel to the pedestrian flow. The bottom of diagonal curb ramps shall have 48 inch minimum clear space within the crosswalk. If diagonal curb ramps have flared sides, they shall also have at least a 24 inch long segment of straight curb located on each side of the curb ramp and within the marked crossing.

It is important to visually impaired persons using the sidewalk that the location of the ramps be as uniform as possible. A contrasting surface texture should be used. On sections without curb and gutter, a contrasting surface texture should be used on the approach to crosswalks.

The Department of Transportation's Roadway and Traffic Design Standards, Index 304, which addresses the design of curb ramps,

may be considered. Designers should keep in mind there are many variables invoked making each street intersection a special problem. For this reason, standard guidelines will not fit all situations and cannot replace the need for the use of sound engineering judgement in the design of curb ramps.

Two ramps per corner are preferred to minimize the problems with entry angle and to decrease the delay to people in wheel chairs or visually impaired pedestrians entering and exiting the roadway.

C.10.a.5 Additional Considerations

For additional information on pedestrian facilities design, including physical separation from the roadway, over- and underpasses, pedestrian crossings, traffic control, sight distance and lighting, refer to Chapter 8 Pedestrian Traffic.

C.10.b. Bicycle Facilities

Provisions for bicycle traffic should be incorporated into the original highway design. All roadways, except limited access highways, should be designed and constructed under the assumption they will be used by bicyclists. Roadway conditions should be favorable for bicycling. This includes safe drainage grates, pavement markings, and railroad crossings, smooth pavements, and signals responsive to bicycles. In addition, facilities such as bicycle lanes, bicycle routes, and shoulder improvements, should be included to the fullest

extent feasible. Specifically, all rural arterial and collector sections within one mile of an urbanized area, should be given consideration for the construction of 4 foot or 5 foot paved shoulders. In addition, all urban arterial and collector sections should be given consideration for either undesignated or designated 4 foot bike lanes.

For additional information of bicycle facilities design and the design of shared use paths, refer to Chapter 9 Bicycle Facilities.

C.10.c Bridge Design Loadings

The minimum design loading for all new and reconstructed bridges shall be HS-20 (see Figures 3-16 and 3-17). Additional information given in AASHTO Standard Specifications for Highway Bridges should be considered.

C.10.d Dead End Streets and Cul-de-sacs

The end of a dead end street should permit travel return with a turn around area, considering backing movements, that will accommodate single truck or transit vehicles without encroachment upon private property. Recommended treatment for dead end streets and cul-de-sacs is given in Figure V - 2 of AASHTO - "A Policy on Geometric Design of Highways and Streets" - 1990.

C.10.e Bus Benches and Transit Shelters

Due to the length of exposure and discomfort from traffic, bus benches should be set back at least 10 feet from the travel lane.

Any bus bench or transit shelter located adjacent to a sidewalk within the right of way of any road on the State Highway or County Road System shall be located so as to leave at least 36 inches clearance for pedestrians and persons in wheelchairs. Such clearance shall be measured in a direction perpendicular to the centerline of the road. A separate bench pad or sidewalk flareout should be considered. Transit shelters should be set back, rather than eliminated during roadway widening.

C.10. f Traffic Calming

Often there are community concerns with controlling travel speeds impacting the safety of a corridor such as in areas of concentrated pedestrian activities, those with narrow right of way, areas with numerous access points, on street parking, and other similar concerns. Local authorities may elect to use traffic calming design features which could include, but not be limited to, the installation of speed humps, speed tables, chicanes, or other pavement undulations. Roundabouts are also another method of dealing with this issue at intersections. These traffic calming design features are not considered traffic control devices as described by the MUTCD.

C.11. Reconstruction

C.11.a. Introduction

The reconstruction (improvement or upgrading) of existing facilities may generate equal or greater safety benefits than similar expenditures for the construction of new streets and highways. Modifications to increase capacity should be evaluated for the potential effect on the highway safety characteristics. The long range objectives should be to bring the existing network into compliance with current standards.

C.11.b. Evaluation of Streets and Highways

The evaluation of the safety characteristics of streets and highways should be directed towards the identification of undesirable features on the existing system. Particular effort should be exerted to identify the location and nature of features with a high crash potential. Methods for identifying and evaluating hazards include the following:

- Identification of any geometric design feature not in compliance with minimum or desirable standards. This could be accomplished through a systematic survey and evaluation of existing facilities.
- Review of conflict points along a corridor.
- Information from maintenance or other personnel.
- Review of crash reports and traffic counts to identify locations with a large number of crashes or a high crash rate.

C.11.c. Priorities

A large percentage of highway reconstruction and improvements is directed toward increasing efficiency and capacity. The program of reconstruction should be based, to a large extent, upon priorities for the improvement of safety characteristics.

The priorities for safety improvements should be based on the objective of obtaining the maximum reduction in accident potential for a given expenditure of funds. Elimination of conditions that may result in serious or fatal crashes should receive the highest priority in the schedule for reconstruction.

Specific high priority problem areas that should be corrected by reconstruction include the following:

- Obstructions in sight distance which be economically corrected. The removal of buildings, parked vehicles, vegetation, large poles or groups of poles that significantly reduce the field of vision, and signs; to improve sight distance on curves and particularly at intersections, can be of immense benefit in reducing crashes. The purchase of required line of sight easements is often a wise expenditure of highway funds. The establishment of sight distance setback lines is encouraged.
- Roadside and median hazards which can often be removed or relocated farther from the traveled way. Where removal is not feasible, objects should be shielded by redirection or energy absorbing devices. The reduction of the roadside hazard problem generally provides a good return on the safety dollar. Details and priorities for roadside hazard reduction, which are presented in CHAPTER 4 - ROADSIDE DESIGN, should be incorporated into the overall priorities of the reconstruction program.
- Poor pavement surfaces which are hazardous should be maintained or reconstructed in accordance with the design criteria set forth in CHAPTER 5 - PAVEMENT DESIGN, CONSTRUCTION, AND MAINTENANCE.
- Specific design features which could be applied during reconstruction to enhance the operations and safety characteristics of a roadway include the following:
 - Addition of roadway lighting
 - The provision of frontage roads of other alternate paths. This may be utilized to improve the efficiency and safety of streets and highways with poor control of access.
 - Widening of pavements and shoulders. This is often an economically feasible method of increasing capacity and reducing traffic hazards. Provision of median barriers (CHAPTER 4 - ROADSIDE DESIGN) can also produce significant safety benefits.

- The removal, streamlining, or modification of drainage structures.
- Alignment modifications are usually extensive and require extensive reconstruction of the roadway. Removal of isolated sharp curves is a reasonable and logical step in alignment modification. If major realignment is to be undertaken, every effort should be made to bring the entire facility into compliance with the requirements for new construction.
- The use of traffic control devices. This is generally an inexpensive method of alleviating certain highway defects.
- Median opening modifications
- Addition of median, channelized islands, and mid-block pedestrian crossings.
- Auxiliary lanes
- Existing bridges that fail to meet current design standards which are available to bicycle traffic, should be retrofitted on an interim basis as follows: As a general practice, bridges 125 feet in length or longer, bridges with unusual sight problem. Steep gradients (which require the cyclist longer time to clear the span) or other unusual conditions and should display the standard W11-1 caution sign with an added sign "On Bridge" at either end of the structure. Special care should be given to the right most portion of the roadway, where bicyclists are expected to travel, assuring smoothness, pavement uniformity, and freedom from longitudinal joints, and to ensure cleanliness. Failure to do so forces bicyclists further into the center portion of the bridge, reducing traffic flow and safety.
- Addition of bike accommodations designated or undesignated.
- Addition of transit facilities, sidewalks, crosswalks, and other pedestrian features.

C.12. Design Exceptions

See CHAPTER 14 - DESIGN EXCEPTIONS for the process to use when the standard criteria found in this Manual cannot be met.

**TABLE 3 - 1
 RECOMMENDED MINIMUM DESIGN SPEED (MPH)**

TYPE OF ROADWAY	URBAN		RURAL	
	*SPEED RESTRICTIONS		*SPEED RESTRICTIONS	
	WITH	WITHOUT	WITH	WITHOUT
Freeway or Expressway	50	60		70
Arterial (Major)	40	55	55	70
Arterial (Minor)	35	50	55	70
Collector (Major)	35	45	50	65
Collector (Minor)	30	40	40	60
Local **	20	30	30	50

* Speed restrictions are features of the design which would effectively limit the operating speed, such as:

- a. short length of roadway (i.e., dead-end street)
- b. closely spaced stop signs, traffic signals or other control devices
- c. locations that would by nature of the surrounding development or land use, indicate to the driver that lower speeds were necessary

** Design speeds lower than 30mph may be used for local, subdivision type roads and streets. Streets with a design speed less than 30mph shall be posted with appropriate legal speed limit signs.

**TABLE 3 - 2
 DESIGN VEHICLES**

Design Vehicle		DIMENSIONS IN FEET					
Type	Symbol	Wheelbase	Overhang		Overall Length	Overall Width	Height
			Front	Rear			
Passenger Car	P	11	3	5	19	7	4.25
Single Unit Truck	SU	20	4	6	30	8.5	13.5
Single Unit Bus	BUS	25	7	8	40	8.5	13.5
Articulated Bus	A-BUS	18+24=42	8.5	9.5	60	8.5	10.5
Motor Home	MH	20	4	6	30	8	--
Car & Camper Trailer	P/T	11+5+18=34**	3	10	49	8	--
Car & Boat Trailer	P/B	11+5+15=31**	3	8	42	8	--
Semi-Trailer Combination, Intermediate	WB-40	13+27=40	4	6	50	8.5	13.5
Semi-Trailer Combination, Large	WB-50	20+30=50	3	2	55	8.5	13.5
Semi-Trailer Combination, Combination	WB-60	9.7+20+9.4* +20.9=60	2	3	65	8.5	13.5

* Distance between rear wheels of front trailer and front wheels of rear trailer

** Distance between rear wheels of trailer and front wheels of car

TABLE 3 - 3
HORIZONTAL CURVATURE

MAXIMUM CURVATURE (DEGREES)			
RURAL Based on $e_{MAX} = 0.10$		URBAN High Speed Highways and Streets Based on $e_{MAX} = 0.10$	
Design Speed	Max. Degree of Curve	Design Speed	Max. Degree of Curve
30	24° 45' (230' radius)	30	20°
35	17° 45'	35	14° 15'
40	13° 15'	40	10° 45'
45	10° 15'	45	8° 15'
50	8° 15'	50	6° 30'
55	6° 30'	55	5°
60	5° 15'		
65	4° 15'		
70	3° 30'		

MINIMUM RADIUS (FEET) URBAN - LOWER SPEED STREETS		
Design Speed	With $e_{MAX} = 0.05$	Without Superelevation
15	40	50
20	75	95
25	140	180
30	225	300

LATERAL CLEARANCE FROM EDGE OF PAVEMENT TO OBSTRUCTION FOR MAXIMUM CURVATURE (DEGREES), BASED ON LINE OF SIGHT ON INSIDE LANE (Lateral Clearance = M Inside Lane e^{+})		
Design Speed	Maximum Curvature	CLEARANCE (FEET)
		Lower SSD
30	24.75°	16
35	17.75°	14
40	13.25°	16
45	10.25°	18
50	8.25°	23
55	6.50°	23
60	5.25°	26
65	4.25°	22
70	3.50°	24

TABLE 3 - 4
RECOMMENDED MAXIMUM GRADES IN PERCENT

TYPE OF ROADWAY	FLAT TERRAIN							ROLLING TERRAIN						
	DESIGN SPEED ' MPH							DESIGN SPEED ' MPH						
	20	30	40	50	60	65	70	20	30	40	50	60	65	70
FREEWAY				4	3	3	3				5	4	4	4
ARTERIAL *			5	4	3	3	3			6	5	4	4	4
COLLECTOR *		7	7	6	5	4			9	8	7	6	5	
LOCAL *	8	7	7	6	5			11	10	9	8	6		
INDUSTRIAL **		4	4	3	3				5	5	4	4		

* May be increased by 2 percent for urban streets under extreme conditions.

** Local and collector streets with significant (15% or more) truck traffic.

For short sections less than 500' and for one-way downgrades, the maximum gradient may be 1% steeper.

TABLE 3 - 5
MAXIMUM CHANGE IN GRADE
WITHOUT USING VERTICAL CURVE

Design Speed (mph)	20	30	40	50	60	65	70
Maximum Change in Grade in Percent	1.20	1.00	.80	.60	.40	.30	.20

TABLE 3 - 6

SIGHT DISTANCES AND LENGTHS OF VERTICAL CURVES

MINIMUM STOPPING SIGHT DISTANCES (FEET) (Based on height of eye of 3.50 feet and height of object 6 inches above the road surface)										
Design Speed (mph)	20	30	35	40	45	50	55	60	65	70
Stopping Sight Distance (feet)	125	200	225	275	325	400	450	525	550	625

ROUNDED K VALUES FOR MINIMUM LENGTHS VERTICAL CURVES										
$L = KA$										
L = LENGTH OF VERTICAL CURVE	A = ALGEBRAIC DIFFERENCE OF GRADES IN PERCENT									
Design Speed (mph)	20	30	35	40	45	50	55	60	65	70
K Values for Crest Vertical Curves	10	30	40	60	80	120	150	190	230	290
K Values for Sag Vertical Curves	20	40	50	60	70	90	100	120	130	150
<ul style="list-style-type: none"> ▶ The length of vertical curve must never be less than three times the design speed of the highway ▶ Curve lengths computed from the formula $L = KA$ should be rounded upward when feasible ▶ The minimum lengths of vertical curves to be used on major highways are shown in the table below 										

MINIMUM LENGTHS FOR VERTICAL CURVES ON MAJOR HIGHWAYS (FEET)			
Design Speed (mph)	50	60	70
Crest Vertical Curves (feet)	300	400	500
Sag Vertical Curves (feet)	200	300	400

MINIMUM PASSING SIGHT DISTANCES (FEET) (Measured from 3.50 feet height of eye to 4.25 feet height of object above the road surface)							
Design Speed (mph)	20	30	40	50	60	65	70
Minimum Passing Sight Distance (feet)	800	1100	1500	1800	2100	2300	2500

**TABLE 3 - 7
 MINIMUM LANE WIDTHS**

	Minimum Lane Width
Freeways	12 feet
Major Arterials	11 feet
Minor Arterials	11 feet
Collectors (Major and Minor)	11 feet
Local Roads *	10 feet
Auxiliary Lanes	10 feet

* Pavement widths may be reduced for the paving of certain existing unpaved subdivision streets and low volume rural roads. See CHAPTER 3 SECTION A for conditions.

**TABLE 3 - 8
 MINIMUM WIDTHS OF PAVEMENT AND SHOULDERS
 AND TWO (2) LANE RURAL HIGHWAYS**

DESIGN SPEED	AVERAGE DAILY TRAFFIC (2 - WAY)				
	250	250 - 400	400 - 750	750 - 1,600	ABOVE 1,600
30	20 feet	20 feet	22 feet	22 feet	24 feet
35	20 feet	20 feet	22 feet	22 feet	24 feet
40	20 feet	20 feet	22 feet	22 feet	24 feet
45	20 feet	20 feet	22 feet	22 feet	24 feet
50	20 feet	20 feet	22 feet	24 feet	24 feet
55	20 feet	22 feet	22 feet	24 feet	24 feet
60	20 feet	22 feet	22 feet	24 feet	24 feet
65	20 feet	22 feet	24 feet	24 feet	24 feet
ALL	WIDTH OF SHOULDER				
	MIN. 6 FEET	MIN. 6 FEET	MIN. 6 FEET	MIN. 8 FEET	MIN. 8 FEET

**TABLE 3 - 9
 SHOULDER WIDTHS FOR MULTILANE RURAL DIVIDED HIGHWAYS**

NUMBER OF LANES EACH DIRECTION	SHOULDER WIDTH			
	OUTSIDE		MEDIAN	
	ROADWAY	BRIDGE	ROADWAY	BRIDGE
2	10' minimum	10'	6' minimum	6'
3 or MORE	10' minimum	10'	10' minimum	10'

**TABLE 3 - 10
 MEDIAN WIDTH FOR FREEWAYS
 (URBAN AND RURAL)**

DESIGN SPEED (MPH)	MINIMUM PERMITTED MEDIAN WIDTH (FEET)
60 and OVER	60 feet **
UNDER 60	40 feet *

* Applicable for urban areas ONLY.

** For new construction ONLY.
 (40 foot minimum allowed when lanes added to median)

**TABLE 3 - 11
 MEDIAN WIDTH, (FEET) FOR RURAL HIGHWAYS
 (MULTILANE FACILITIES)**

DESIGN SPEED	MINIMUM
55 MPH AND OVER	40 feet
UNDER 55 MPH	22 feet

MEDIAN WIDTH, (FEET) FOR URBAN STREETS

DESIGN SPEED	MINIMUM
50 MPH	19.5 feet
45 MPH and LESS	15.5 feet

Paved medians with a minimum of 10 feet, may be used for two-way turn lanes and painted medians, when design speeds are 40 mph or less.

**TABLE 3 - 12
 MINIMUM WIDTH OF CLEAR ZONE**

Design Speed

Type of Facility	DESIGN SPEED (MPH)							
	25 AND BELOW	30	35	40	45	50	55	60 AND ABOVE
	MINIMUM CLEAR ZONE (FEET)							
Rural *	6	6 Local 10 Collectors 14 Arterials	6 Local 10 Collectors 14 Arterials	10 Collectors 14 Arterials	14 Arterials and Collectors ADT < 1500 18 Arterials and Collectors ADT ≥ 1500	14 Arterials and Collectors ADT < 1500 18 Arterials and Collectors ADT ≥ 1500	18 Arterials and Collectors ADT < 1500 24 Arterials and Collectors ADT ≥ 1500	18 Arterials and Collectors ADT < 1500 30 Arterials and Collectors ADT ≥ 1500
Urban *	1 ½	4 **	4 **	4 **	4 **	N/A ..	N/A ..	N/A ..

* From face of curb

** On projects where the 4 foot minimum offset cannot be reasonably obtained and other alternatives are deemed impractical, the minimum may be reduced to 1 ½'.

· Use rural for urban facilities when no curb and gutter is present. Measured from the edge of through travel lane on rural section.

.. Curb and gutter not to be used on facilities with design speed > 45mph.

NOTE: ADT in Table 3 - 12 refers to Design Year ADT.

**TABLE 3 - 13
 ACCESS CONTROL FOR ALL LIMITED ACCESS HIGHWAYS**

	URBAN	RURAL
Minimum Spacing		
Interchanges	1 to 3 miles	3 to 25 miles
Maneuver Restrictions		
Crossing Maneuvers	VIA Grade Separation Only	
Exit and Entrance	From Right Side Only	
Turn Lane Required	Acceleration Lane at all Entrances Deceleration Lane at all Exits	

**TABLE 3 - 14
 SIGHT DISTANCE FOR APPROACH TO STOPS**

(Rounded Values)

DESIGN SPEED (MPH)	10	20	30	40	50	60	65	70
STOPPING SIGHT DISTANCE (FEET) (Minimum)	50	125	200	275	400	525	550	625

**TABLE 3 - 15
 LENGTH OF TAPER FOR USE IN CONDITIONS
 WITH FULL WIDTH SPEED CHANGE LANES**

DESIGN SPEED (MPH)	30	40	50	60	65	70
LENGTH OF TAPER (FEET)*	150	190	230	270	290	300

* For urban street auxiliary lanes shorter tapers may be used due to lower operating speeds. Refer to Figure 3 - 15 for allowable taper rates.

TABLE 3 - 16
DESIGN LENGTHS OF SPEED CHANGE LANES
FLAT GRADES - 2 PERCENT OR LESS

Design Speed of turning roadway curve (mph)		Stop Condition	15	20	25	30	35	40	45	50
Minimum curve radius (feet)			50	90	150	230	310	430	550	690
Design Speed of Highway (mph)	Length of Taper (feet)*	Total length of DECELERATION LANE, including taper (feet)								
		30	150	385	335	310	290	---	---	---
40	190	505	485	455	425	375	345	---	---	---
50	230	665	635	615	585	545	515	455	405	---
60	270	800	770	760	730	700	680	610	570	510
65	290	860	830	820	780	770	720	670	620	570
70	300	915	890	870	850	810	790	730	690	640
Design Speed of Highway (mph)	Length of Taper (feet)*	Total length of ACCELERATION LANE, including taper, (feet)								
		30	150	340	---	---	---	---	---	---
40	190	570	510	440	410	330	---	---	---	---
50	230	990	930	860	810	730	610	390	---	---
60	270	1440	1390	1340	1270	1180	1070	860	670	440
70	300	1890	1840	1800	1710	1630	1530	1310	1130	880

* For urban street auxiliary lanes, shorter tapers may be used due to lower operating speeds. Refer to Figure 3 - 15 for allowable taper rates.

TABLE 3 - 17
RATIO OF LENGTH OF SPEED CHANGE LANE ON GRADE
TO LENGTH ON LEVEL

DECELERATION LANE			ACCELERATION LANE					
Design Speed of Highway (mph)	RATIO		Design Speed of Highway (mph)	Design Speed of Turning Roadway (mph)				
All	3% -4% Upgrade 0.9	3%-4% Downgrade 1.2		20	30	40	50	
				3% - 4% Upgrade			3% - 4% Downgrade	
	5% - 6% Upgrade 0.8	5% - 6% Downgrade 1.35	40	1.3	1.3	---	---	0.7
			50	1.3	1.4	1.4	---	0.65
			60	1.4	1.5	1.5	1.6	0.6
			70	1.5	1.6	1.7	1.8	0.6
Ratios in this table multiplied by the values in Table 3 - 16 give the length of speed changes lane for the respective grade.				5% - 6% Upgrade			5% - 6% Downgrade	
			40	1.5	1.5	---	---	0.6
			50	1.5	1.7	1.9	---	0.55
			60	1.7	1.9	2.2	2.5	0.5
			70	2.0	2.2	2.6	3.0	0.5

TABLE 3-18

MINIMUM DECELERATION LENGTHS FOR EXIT TERMINALS

Highway Design Speed, MPH	L = Deceleration Length - Feet								
	For Design Speed Of Exit Curve - MPH								
	Stop Condition	15	20	25	30	35	40	45	50
30	235	185	160	140	-	-	-	-	-
40	315	295	265	235	185	155	-	-	-
50	435	405	385	355	315	285	225	175	-
60	530	500	490	460	430	410	340	300	240
65	570	540	530	490	480	430	380	330	280
70	615	590	570	550	510	490	430	390	340

EXPRESSWAY EXIT TERMINALS

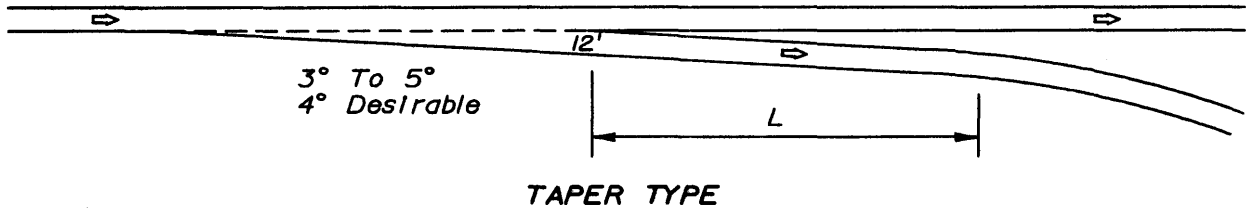

Recommended when design speed at exit curve is 50 MPH or greater and when approach visibility is good.

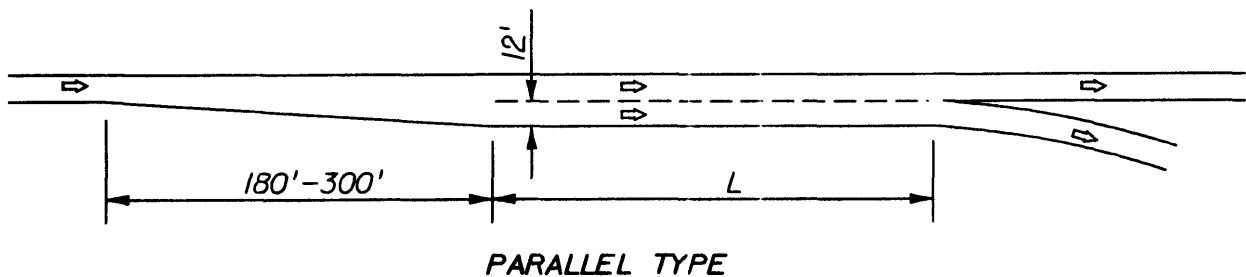

Recommended when design speed at exit curve is less than 50 MPH or when approach visibility is not good.

TABLE 3-19

MINIMUM ACCELERATION LENGTHS FOR ENTRANCE TERMINALS

Highway Design Speed, MPH	L = Acceleration Length - Feet								
	Stop Condition	15	20	25	30	35	40	45	50
30	190	-	-	-	-	-	-	-	-
40	380	320	250	220	140	-	-	-	-
50	760	700	630	580	500	380	160	-	-
60	1,170	1,120	1,070	1,000	910	800	590	400	170
70	1,590	1,540	1,500	1,410	1,330	1,230	1,010	830	580

EXPRESSWAY ENTRANCE TERMINALS

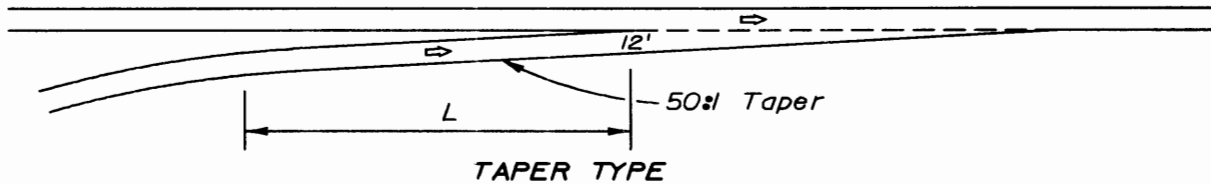

Recommended when design speed at entrance curve is 50 MPH or greater.

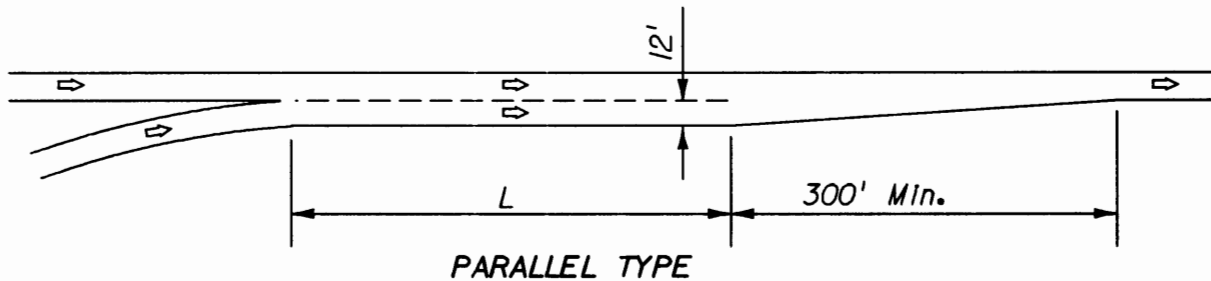

Recommended when design speed at entrance curve is less than 50 MPH.

**TABLE 3 - 20
CALCULATED AND DESIGN VALUES FOR PAVEMENT WIDENING ON OPEN HIGHWAY CURVES**

Degree of Curve	24 ft					22 ft					20 ft			
	Design Speed (mph)					Design Speed (mph)					Design Speed (mph)			
	30	40	50	60	70	30	40	50	60	70	30	40	50	60
1	0.0	0.0	0.0	0.0	0.0	0.5	0.5	0.5	1.0	1.0	1.5	1.5	1.5	2.0
	0.0	0.0	0.0	0.5	0.5	1.0	1.0	1.0	1.5	1.5	2.0	2.0	2.0	2.5
3	0.0	0.0	0.5	0.5	1.0	1.0	1.0	1.5	1.5	2.0	2.0	2.0	2.5	2.5
4	0.0	0.5	0.5	1.0	1.0	1.0	1.5	1.5	2.0	2.0	2.0	2.5	2.5	3.0
5	0.5	0.5	1.0	1.0	—	1.5	1.5	2.0	2.0	—	2.5	2.5	2.5	3.0
6	0.5	1.0	1.0	1.5	—	1.5	2.0	2.0	2.5	—	2.5	3.0	3.0	3.5
7	0.5	1.0	1.5	—	—	1.5	2.0	2.5	—	—	2.5	3.0	3.5	—
8	1.0	1.0	1.5	—	—	2.0	2.0	2.5	—	—	3.0	3.0	3.5	—
9	1.0	1.5	2.0	—	—	2.0	2.5	3.0	—	—	3.0	3.5	4.0	—
10-11	1.0	1.5	—	—	—	2.0	2.5	—	—	—	3.0	3.5	—	—
12-14.5	1.5	2.0	—	—	—	2.5	3.0	—	—	—	3.5	4.0	—	—
15-18	2.0	—	—	—	—	3.0	—	—	—	—	4.0	—	—	—
19-21	2.5	—	—	—	—	3.5	—	—	—	—	4.5	—	—	—
22-25	3.0	—	—	—	—	4.0	—	—	—	—	5.0	—	—	—
26-26.5	3.5	—	—	—	—	4.5	—	—	—	—	5.5	—	—	—

Notes: Values less than 2.0 may be disregarded.
 3-lane pavements: multiply above values by 1.5.
 4-lane pavements: multiply above values by 2.

Where semi-trailer volumes are significant up to WB-50/60 increase tabular values of widening by 0.5 for curves of 10° to 16° and by 1.0 for curves 17° and sharper. For WB-62's increase values of widening by 0.5 for curves 4° to 8°, by 1.0 for curves 9° to 11°, 1.5 for curves 12° to 20°, 2.0 for curves 21° to 27°, 2.5 for curves 28° to 30°.

For WB-67's increase values of widening by 0.5 for curves 3° to 7°, by 1.0 for curves 8° to 10°, by 1.5 for curves 11° to 15°, by 2.0 for curves 16° to 20°, by 2.5 for curves 21° to 25°, 3.0 for curves 25° to 30°.

For WB-114's increase values of widening by 0.5 for curves 1° to 2°, 1.0 for curves 3° to 5°, 1.5 for curves 6° to 8°, 2.0 for curves 9° to 10°, 2.5 for curves 11° to 13°, 3.5 for curves 14° to 17°, 4.0 for curves 18° to 20°, 4.5 for curves 21° to 23°, 5.0 for curves 24° to 26°, 6.0 for curves 27° to 28°, and 6.5 for curves 29° to 30°.

**TABLE 3 - 21
 DESIGN WIDTHS OF PAVEMENTS FOR TURNING ROADWAYS**

Pavement Width (ft)									
Radius on Inner Edge of Pavement R (ft)	Case I One-Lane, One Way Operation - No Provision for Passing a Stalled Vehicle			Case II One-Lane, One Way Operation - With Provision for Passing a Stalled Vehicle			Case III Two-Lane Operation - Either One-Way or Two-Way		
	Design Traffic and Conditions								
	A	B	C	A	B	C	A	B	C
50	18	18	23	23	25	29	31	36	42
75	16	17	19	21	23	27	29	33	37
100	15	16	18	20	22	25	28	31	35
150	14	16	17	19	21	24	27	30	33
200	13	16	16	19	21	23	27	29	31
300	13	15	16	18	20	22	26	28	30
400	13	15	16	18	20	22	26	28	29
500	12	15	15	18	20	22	26	28	29
Tangent	12	15	15	17	19	21	25	27	27

Width Modification Regarding Edge of Pavement Treatment:

No stabilized shoulder	None	None	None
Mountable curb	None	None	None
Barrier curb:			
one side	Add 1 ft	None	Add 1 ft
two side	Add 2 ft	Add 1 ft	Add 2 ft
Stabilized shoulder, one or both sides	None	Deduct shoulder width; minimum pavement width as under case	Deduct 2 ft where shoulder is 4 ft or wider

Note: Traffic Condition A = predominately P vehicles, but some consideration for SU trucks.
 Traffic Condition B = sufficient SU vehicles to govern design, but some consideration for semitrailer vehicles.
 Traffic Condition C = sufficient bus and combination-types of vehicles to govern design.

TABLE 3 - 22
Superelevation Rates for Curves at Intersections

Radius (ft)	Degree of Curve	Minimum Superelevation Rate for Intersection Curves with Design Speed (mph) of						
		10	15	20	25	30	35	40
25	—	0.00*	—	—	—	—	—	—
50	—	0.00*	0.00*	—	—	—	—	—
90	63.6	0.00*	0.00*	0.02	—	—	—	—
150	38.2	0.00*	0.00*	0.02	0.04	—	—	—
230	24.8	0.00*	0.00*	0.02	0.03	0.06	—	—
310	18.5	0.00*	0.00*	0.02	0.03	0.05	0.08	—
430	13.3	0.00*	0.00*	0.02	0.03	0.04	0.06	0.09
600	9.6	0.00*	0.00*	0.02	0.02	0.03	0.05	0.07
1000	5.7	0.00*	0.00*	0.02	0.02	0.03	0.04	0.05
1500	3.8	0.00*	0.00*	0.02	0.02	0.02	0.03	0.04
2000	2.9	0.00*	0.00*	0.02	0.02	0.02	0.02	0.03
3000	1.9	0.00*	0.00*	0.02	0.02	0.02	0.02	0.02

* The rate of 0.02 is considered the practical minimum for effective drainage across the surface.

Note: Preferably use superelevation rates greater than these minimum values. AASHTO "A Policy on Geometric Design of Highways and Streets", 1990, Table IX-12, should also be considered.

TABLE 3 - 23
Maximum rate of change in pavement edge elevation for curves at intersections

Design Speed (mph)	15-25	30	40	50	55	60	65	70
Maximum relative gradients for profiles between the edge of two lane pavement and the centerline (percent)	0.71	0.67	0.58	0.50	0.47	0.45	0.41	0.40

Note: The above table is recommended for curves through intersections and coincides with Table 3 - 24. Change in pavement edges divided by the roadway width (24 ft) should not exceed those rates set in the table.

TABLE 3 - 24
Maximum algebraic difference in pavement cross slope at turning roadway terminals

Design Speed of Exit or Entrance Curve (mph)	Maximum Algebraic Difference in Cross Slope at Crossover Line (percent)
15 and 20	5.0 to 8.0
25 and 30	5.0 to 6.0
35 and over	4.0 to 5.0

FIGURE 3 - 1
 RURAL HIGHWAYS, URBAN FREEWAYS
 AND HIGH SPEED URBAN ARTERIALS

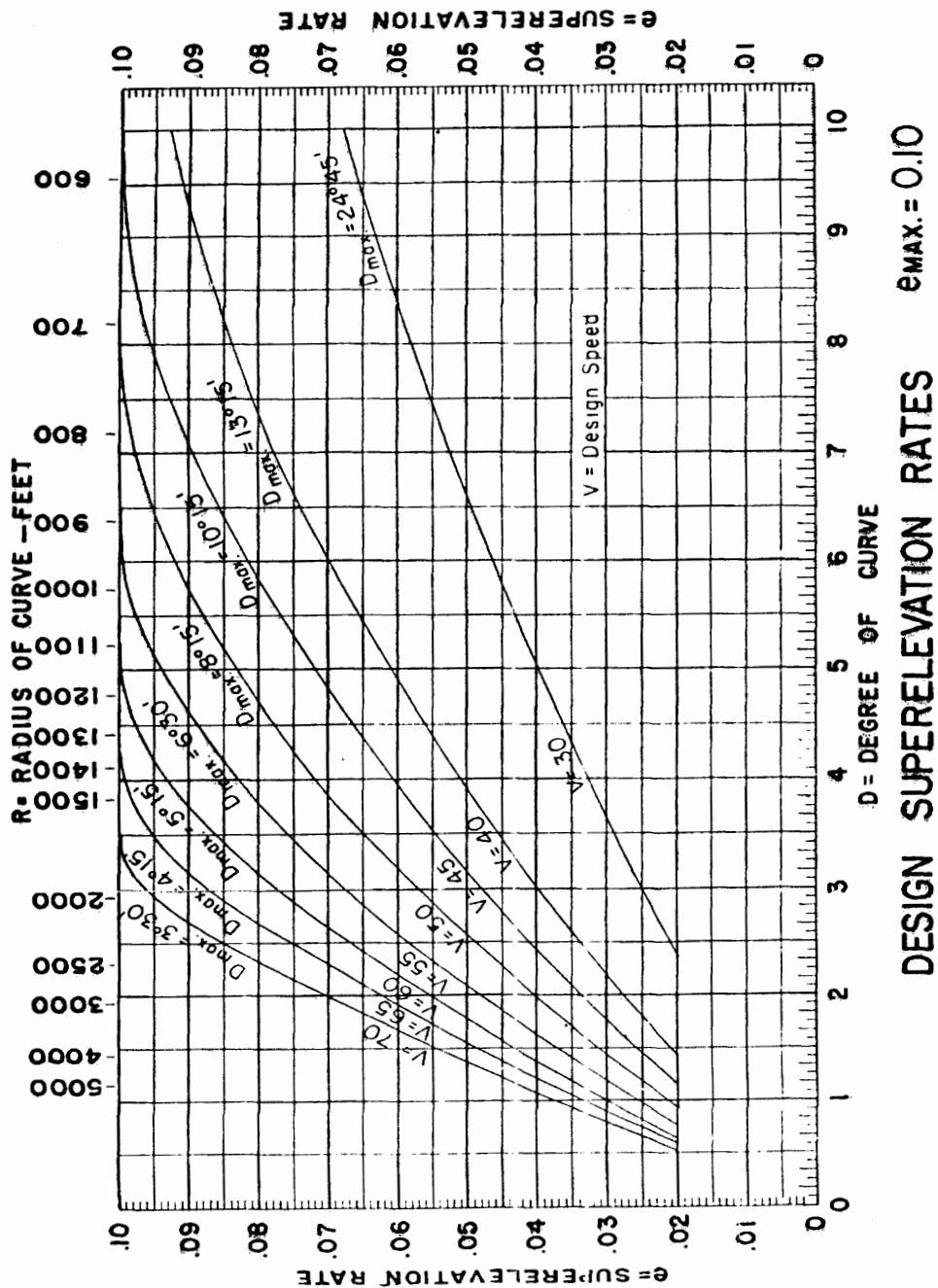
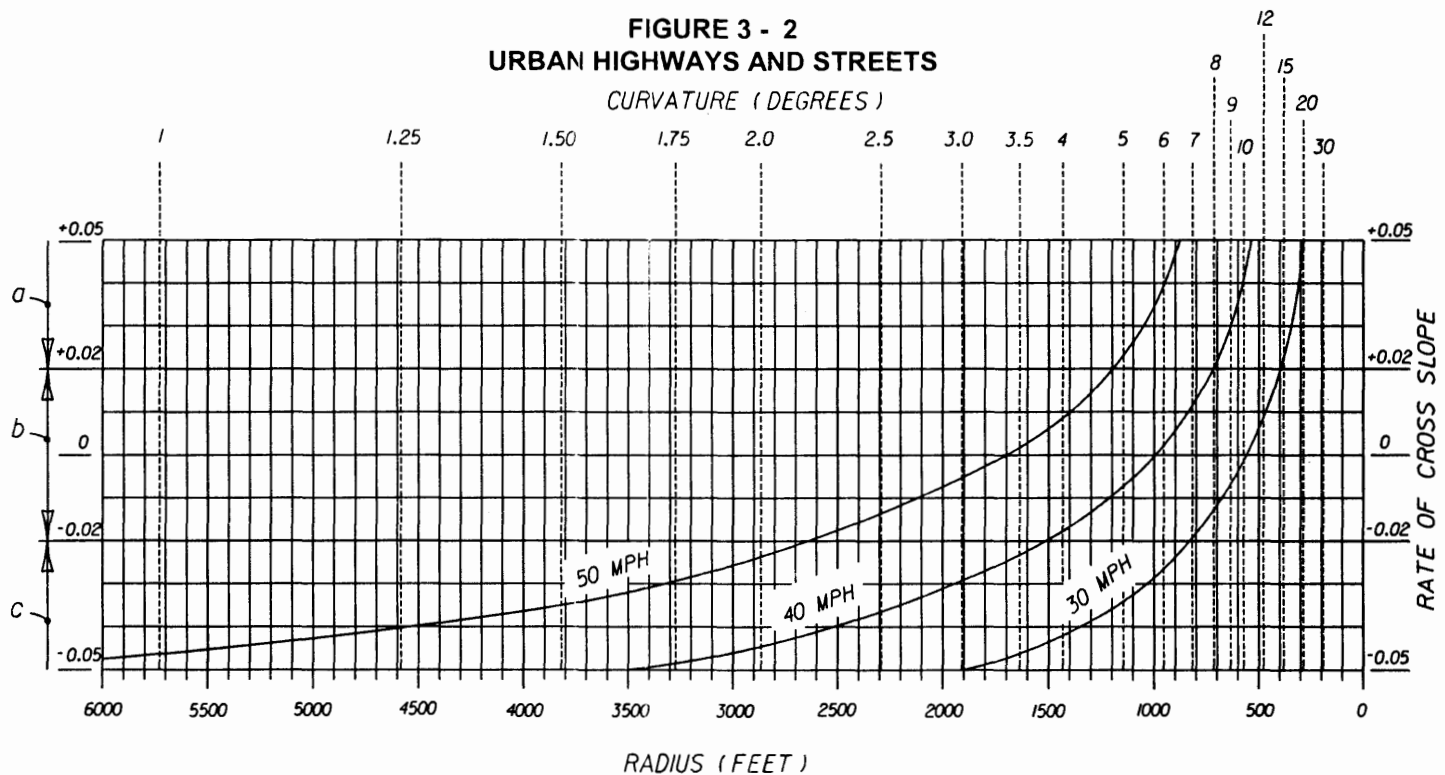
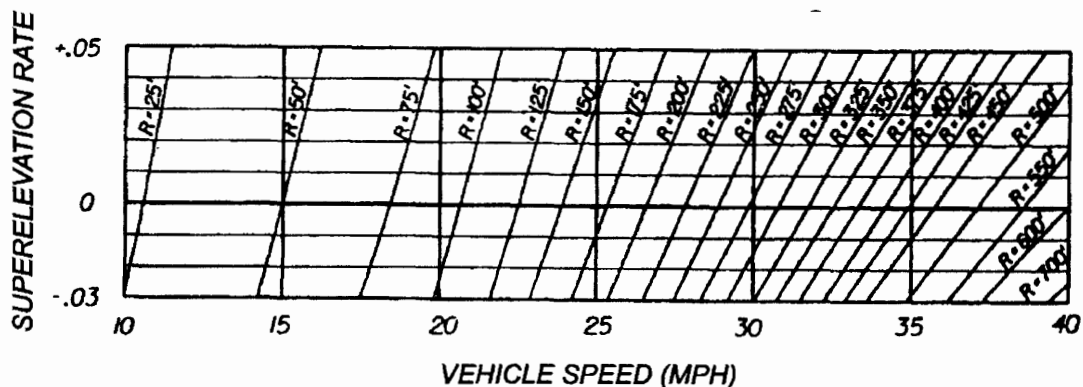

FIGURE 3 - 2
URBAN HIGHWAYS AND STREETS
 CURVATURE (DEGREES)



- a: When the speed curves and the degree of curve lines intersect above this line, the pavement is to be superelevated (positive slope) at the rates indicated at the lines intersecting points.
- b: When the speed curves and the degree of curve lines intersect between these limits, the pavement is to be superelevated at the rate of 0.02 (positive slope).
- c: When the speed curves and the degree of curve lines intersect below this line, The pavement is to have normal crown (typically 0.02 and 0.03 downward slopes).

SUPERELEVATION RATES (e) FOR URBAN HIGHWAYS



MAXIMUM SAFE SPEED FOR HORIZONTAL CURVES
URBAN-LOWER SPEED STREETS

FIGURE 3 - 2A
 SIGHT DISTANCE ON CURVES

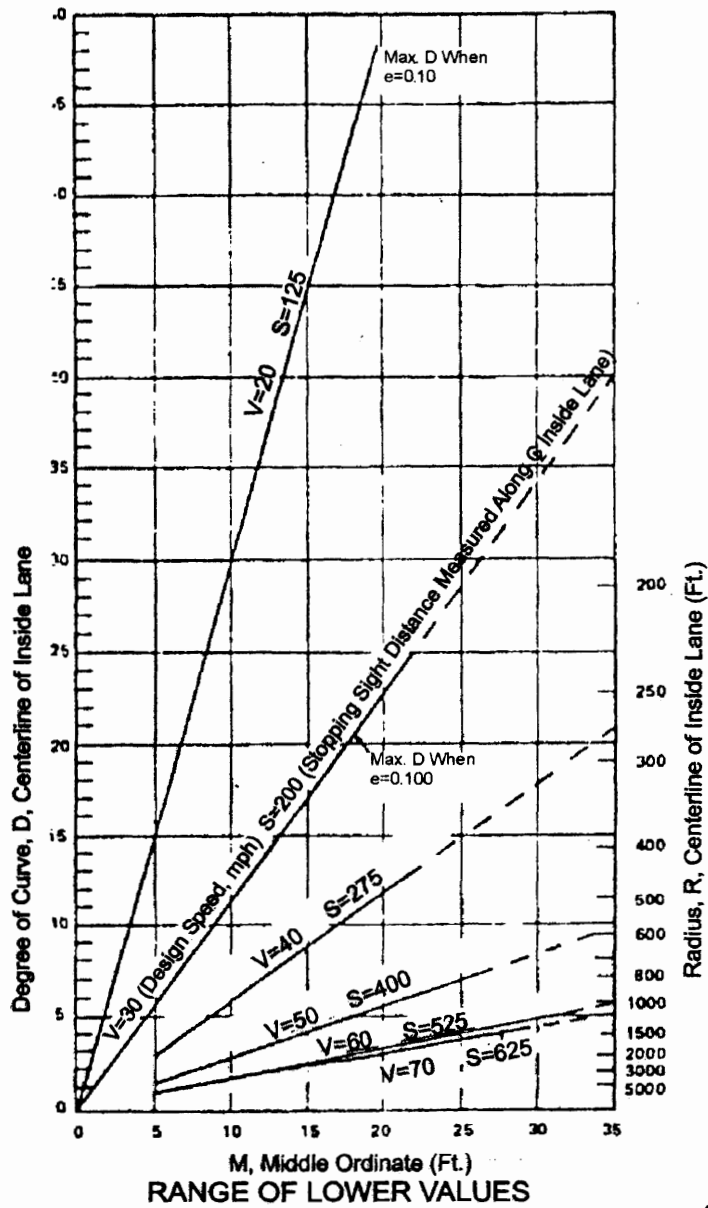

$$M = \frac{5730}{D} \left(1 - \cos \frac{SD}{200} \right)$$

$$R = \frac{5730}{D} \text{ and } \theta = \frac{SD}{200}$$

$$M = R (1 - \cos \theta)$$

$$M = R \left(1 - \cos \frac{28.65S}{R} \right)$$

Where

S=Stopping Sight Distance (FT)

D= Degree of Curve

M=Middle Ordinate (FT)

R=Radius (FT)

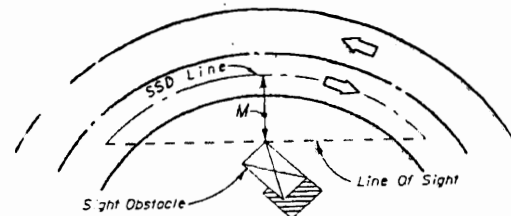

RELATION BETWEEN DEGREE OF CURVE AND VALUE OF MIDDLE ORDINATE NECESSARY TO PROVIDE STOPPING SIGHT DISTANCE ON HORIZONTAL CURVES UNDER OPEN ROAD CONDITIONS

FIGURE 3 - 3
CRITICAL LENGTH VERSUS UPGRADE

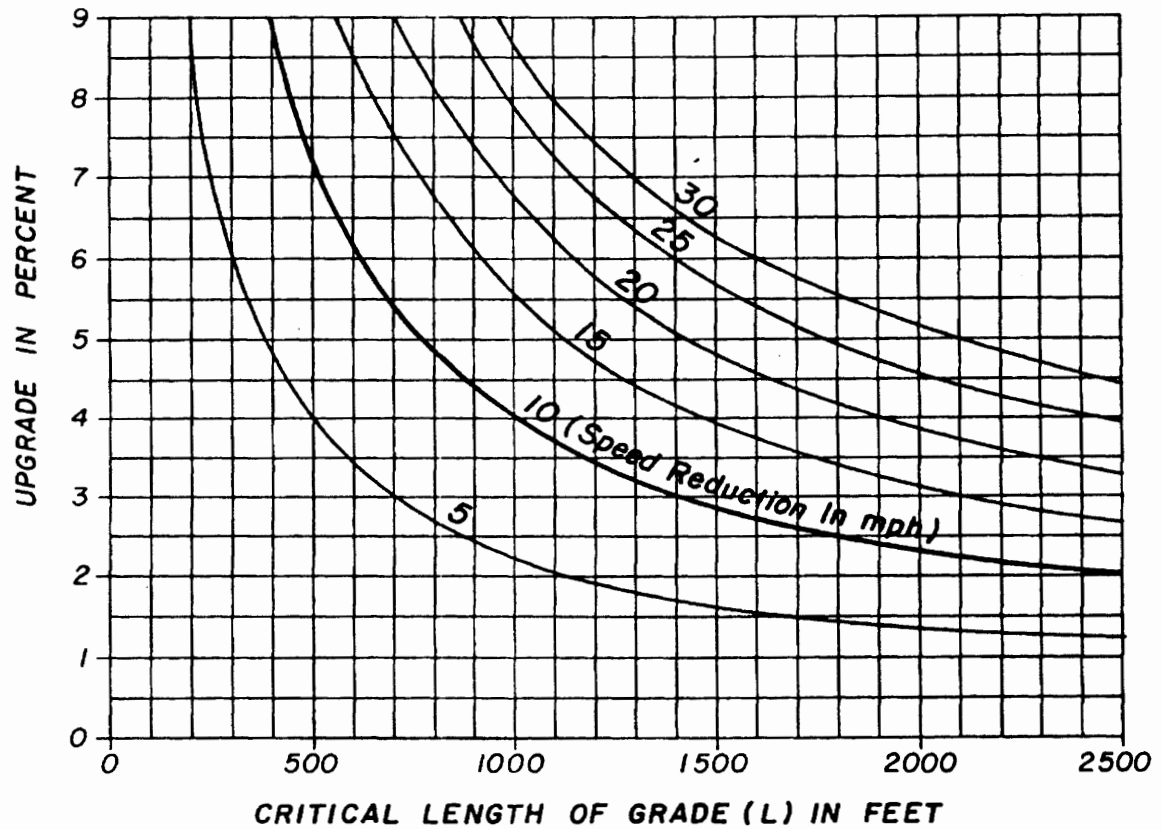

Critical lengths of grade for design, assumed typical heavy truck of 300 lb./hp., entering speed = 55 mph.

FIGURE 3 - 4
LENGTH OF CREST VERTICAL CURVE
(Stopping Sight Distance)

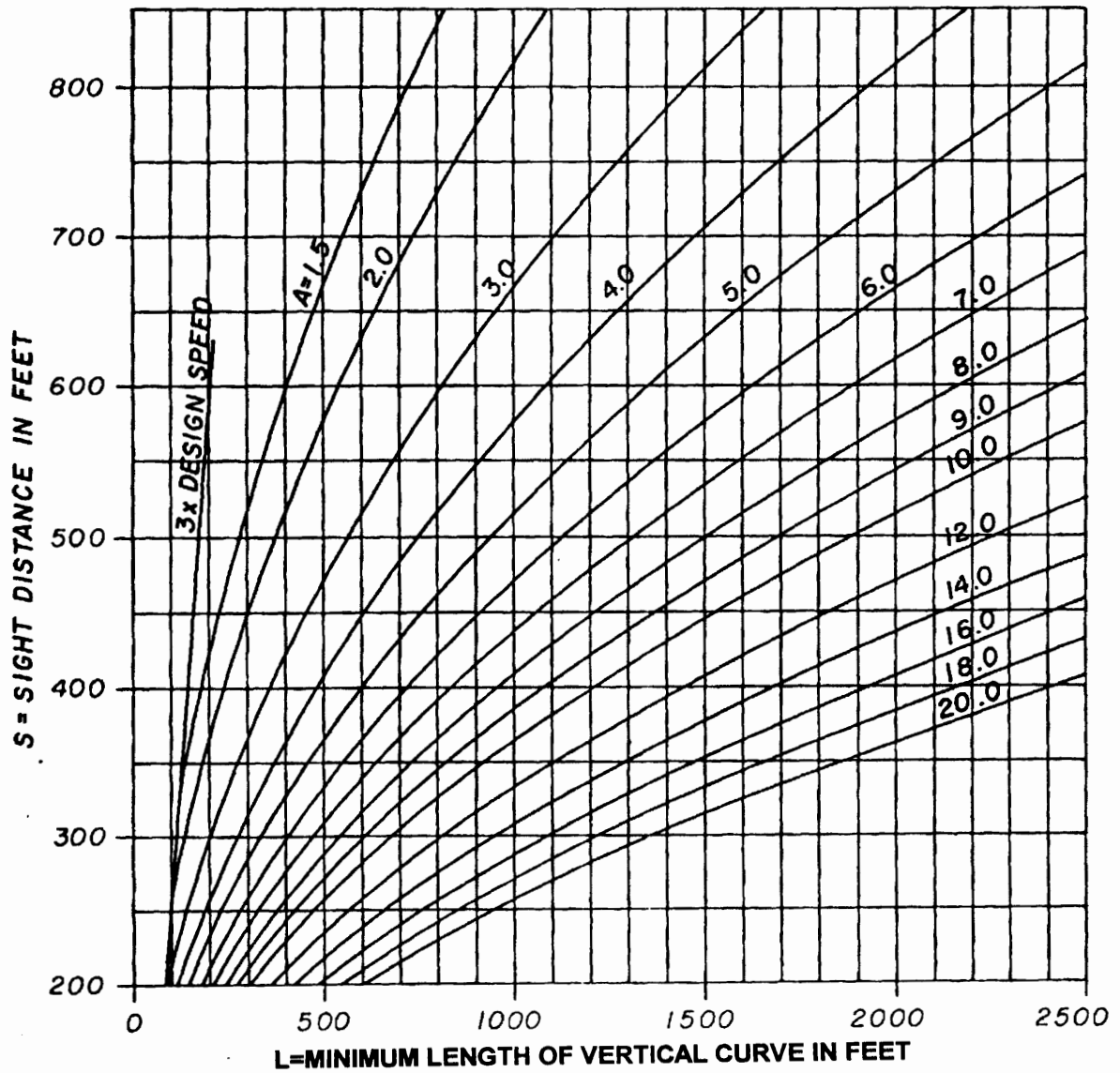

Lengths of vertical curves are computed from the formula:
 A = Algebraic Difference In Grades In Percent
 S = Sight Distance

$$L = \frac{AS^2}{1329}$$

FIGURE 3 - 5
LENGTH OF CREST VERTICAL CURVE
(Passing Sight Distance)

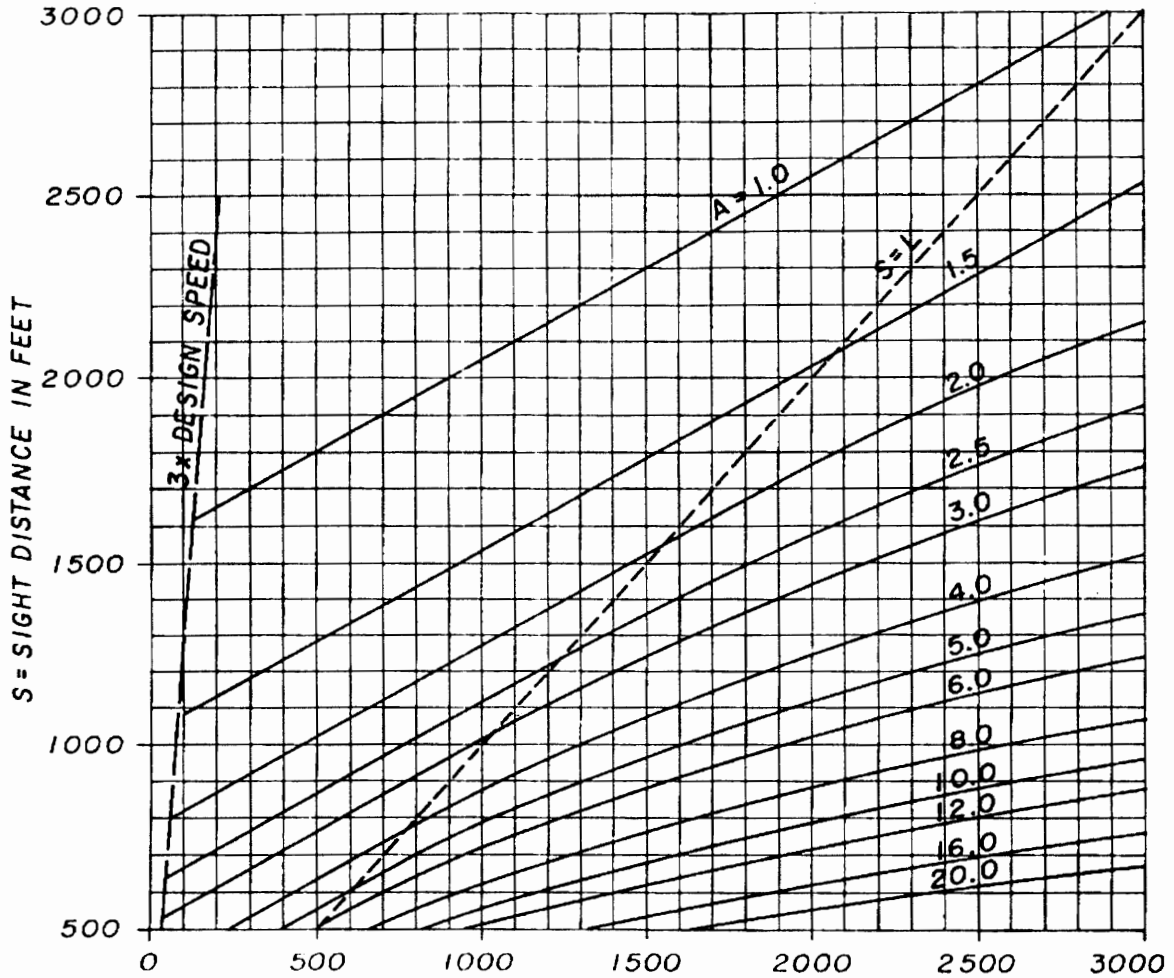

L = MINIMUM LENGTH OF VERTICAL CURVE IN FEET

The sight distance is computed from the following formulas:

$$S < L, L = \frac{AS^2}{3093} \quad S > L, L = 2S - \frac{3093}{A}$$

A = Algebraic Difference In Grades, Percent

S = Sight Distance

L = Length Of Vertical Curve

FIGURE 3 - 6
LENGTH OF SAG VERTICAL CURVE
(Headlight Sight Distance)

Lengths of vertical curves are computed from the formula:

$$L = \frac{AS^2}{400 + 3.5(S)}$$

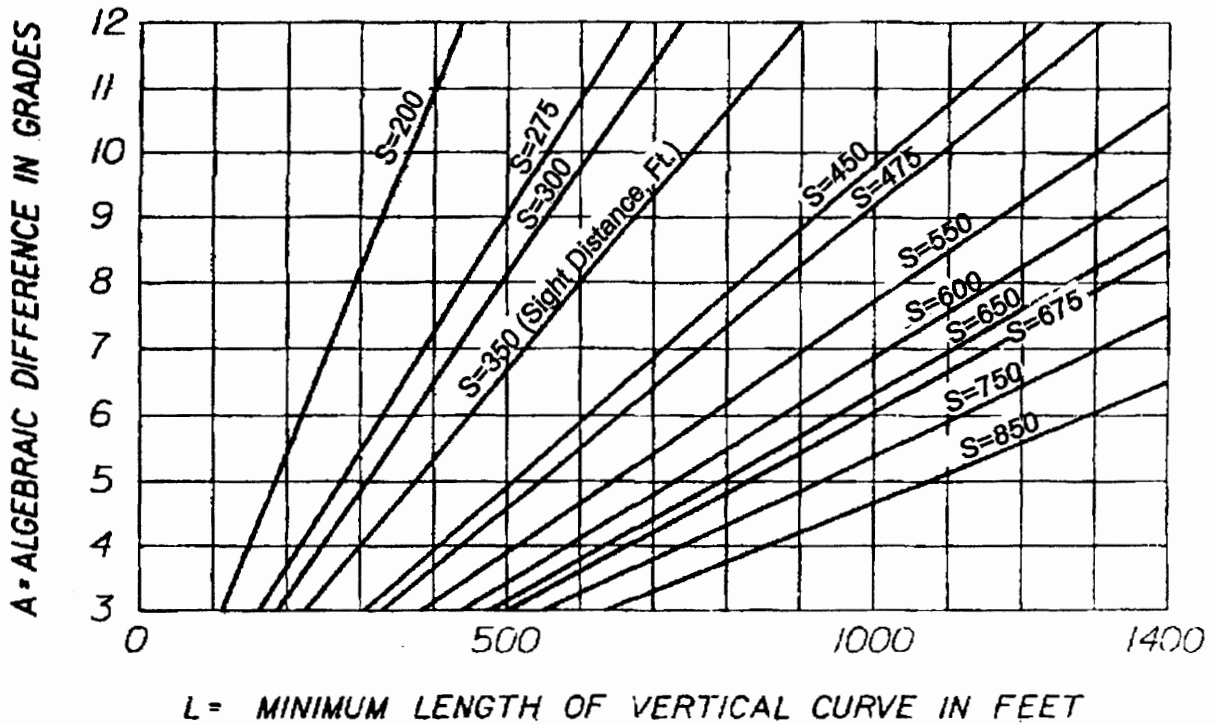

FIGURE 3 - 7
 SIGHT DISTANCES FOR APPROACH TO STOP ON GRADES

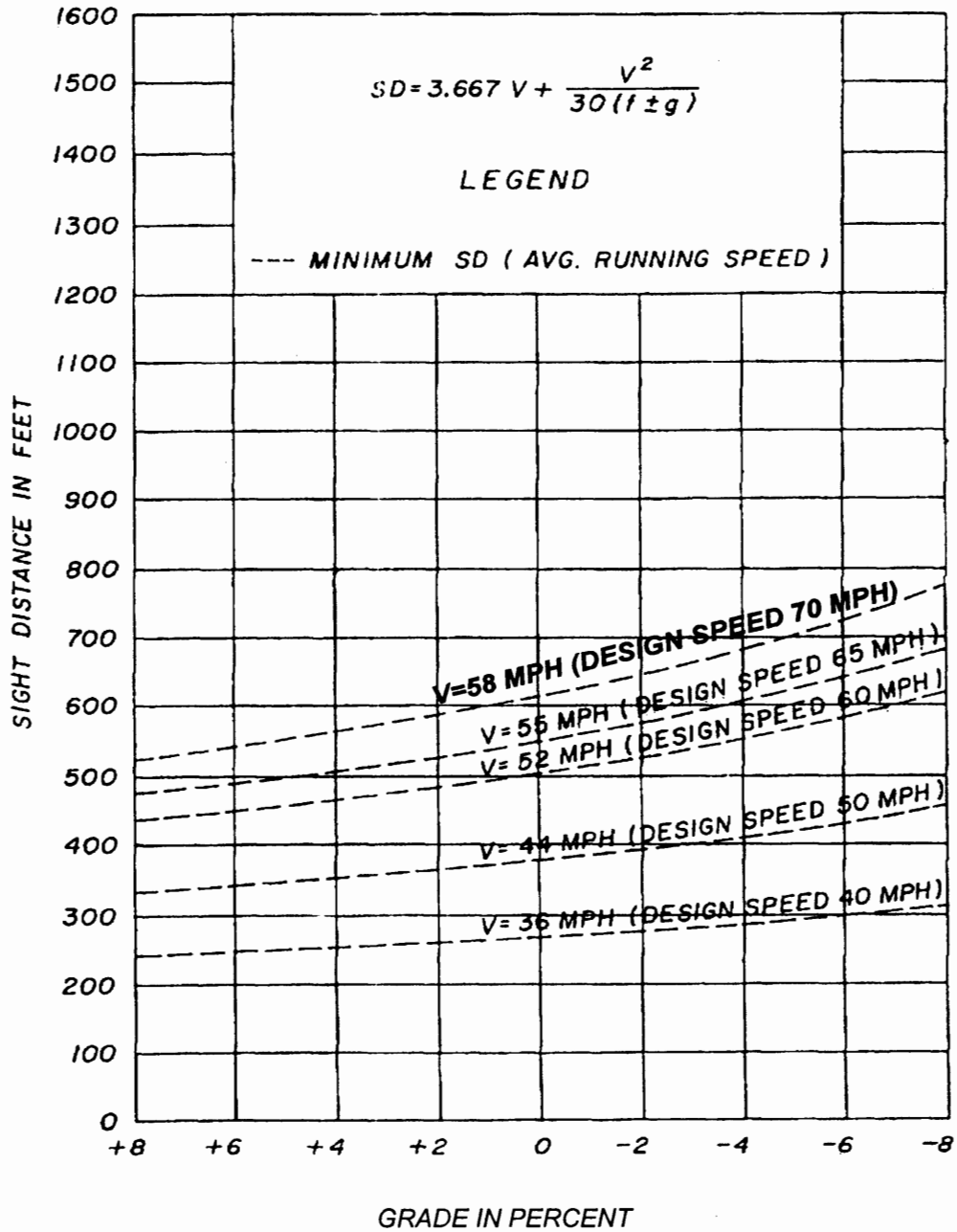

FIGURE 3-8
SIGHT DISTANCE FOR CROSSING MANEUVER
(Affect Of Grade Not Included)
P-CLASS VEHICLES

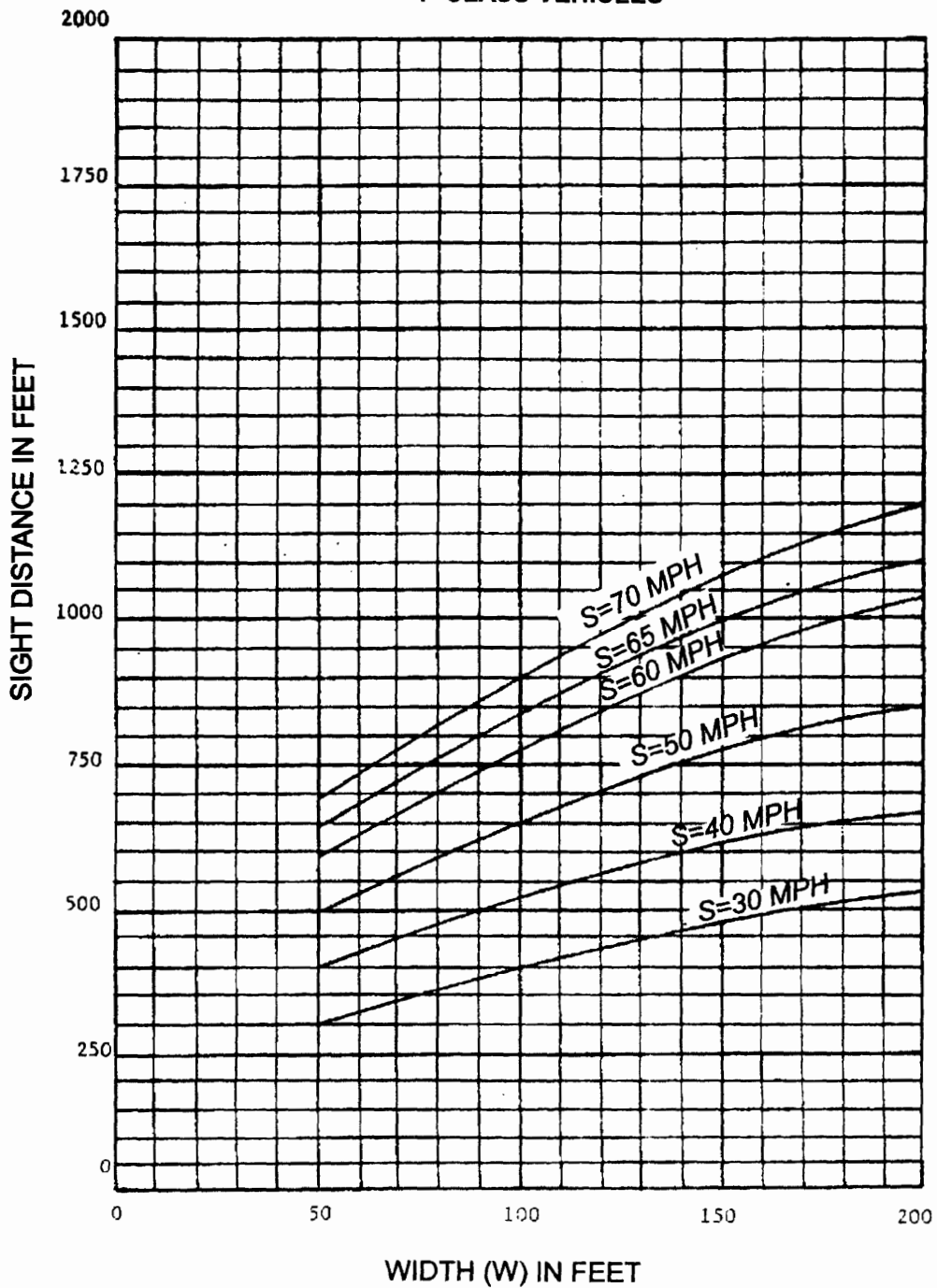

FIGURE 3-9
SIGHT DISTANCE FOR CROSSING MANEUVER
(Affect of Grade Not Included)
SU & BUS-CLASS VEHICLES

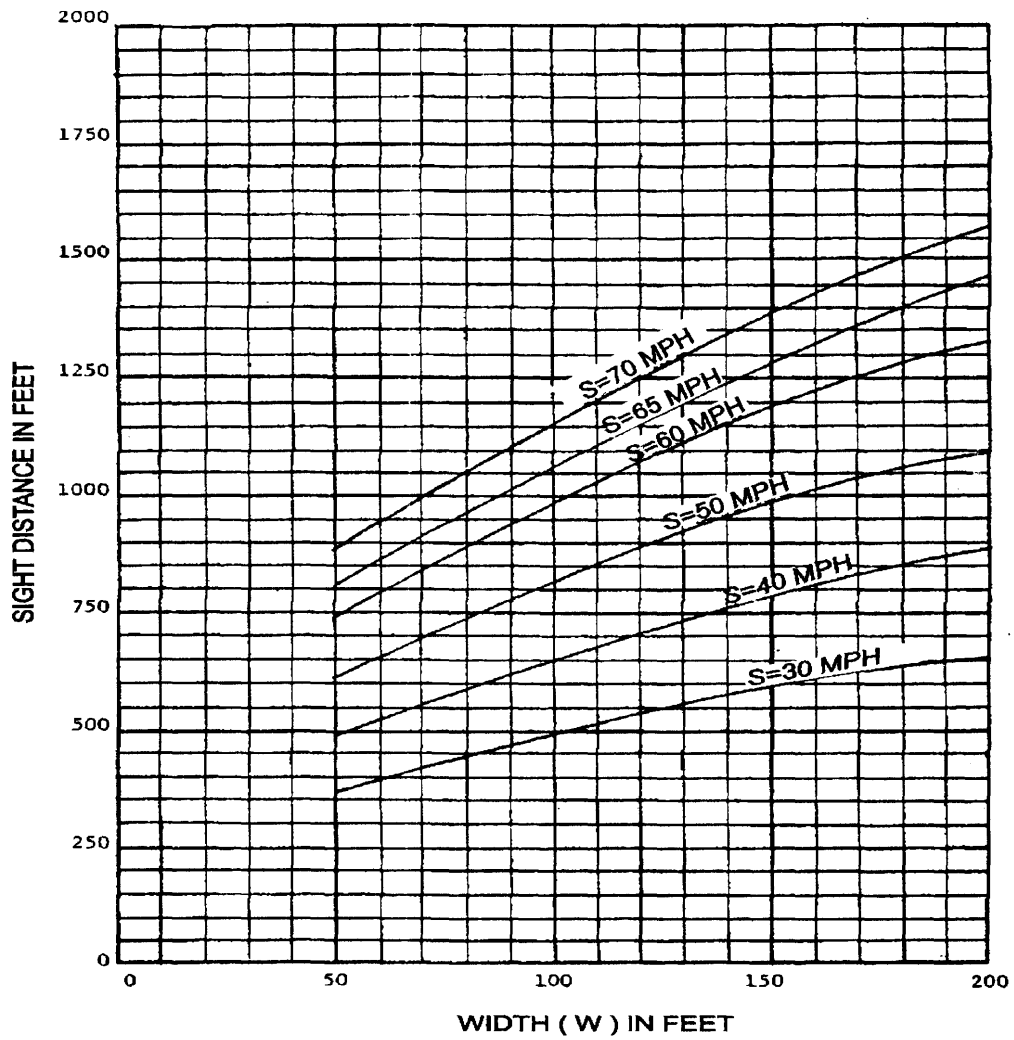

FIGURE 3-10
SIGHT DISTANCE FOR CROSSING MANEUVER
(Affect Of Grade Not Included)

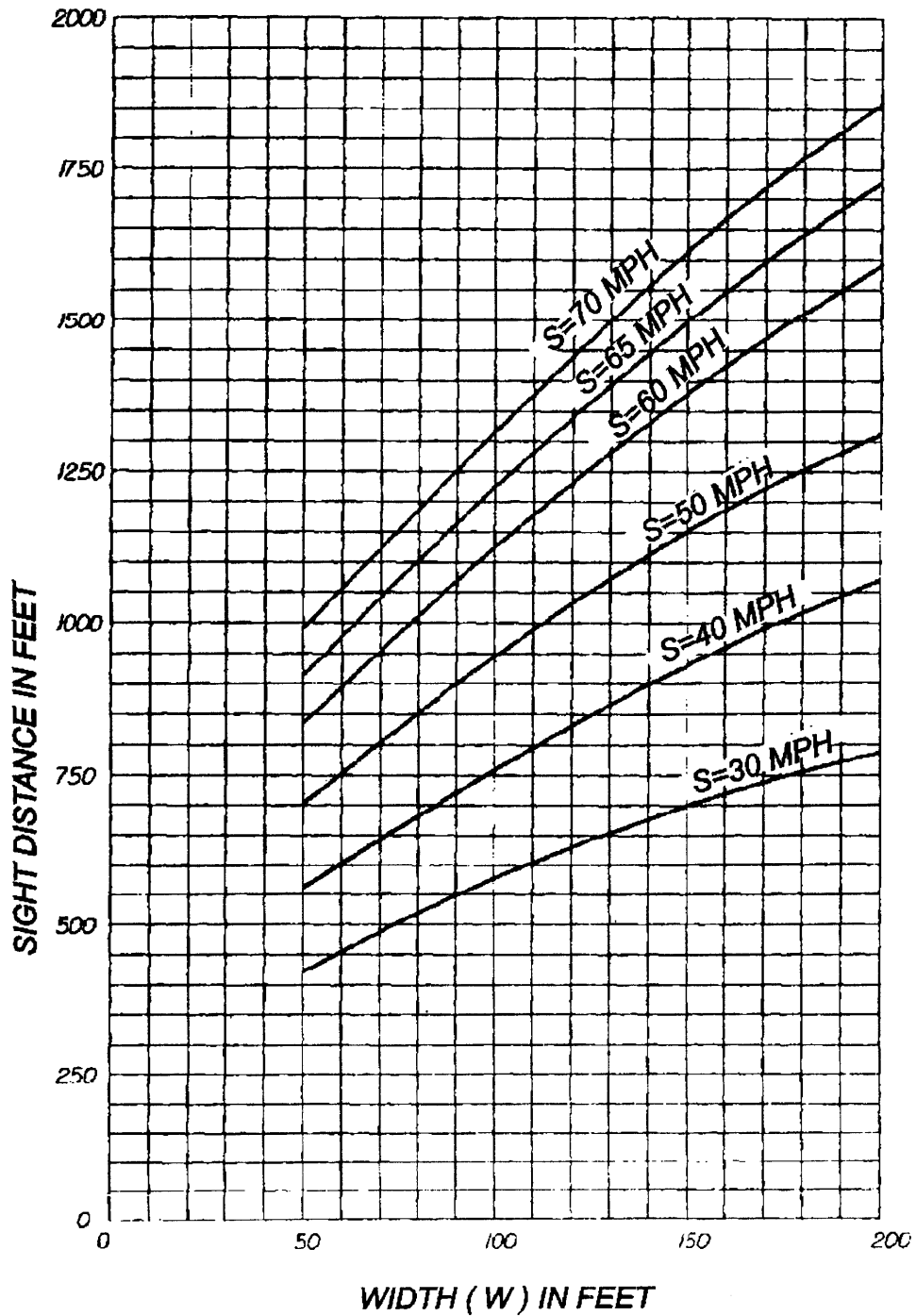

FIGURE 3 - 11
INTERSECTION SIGHT DISTANCE

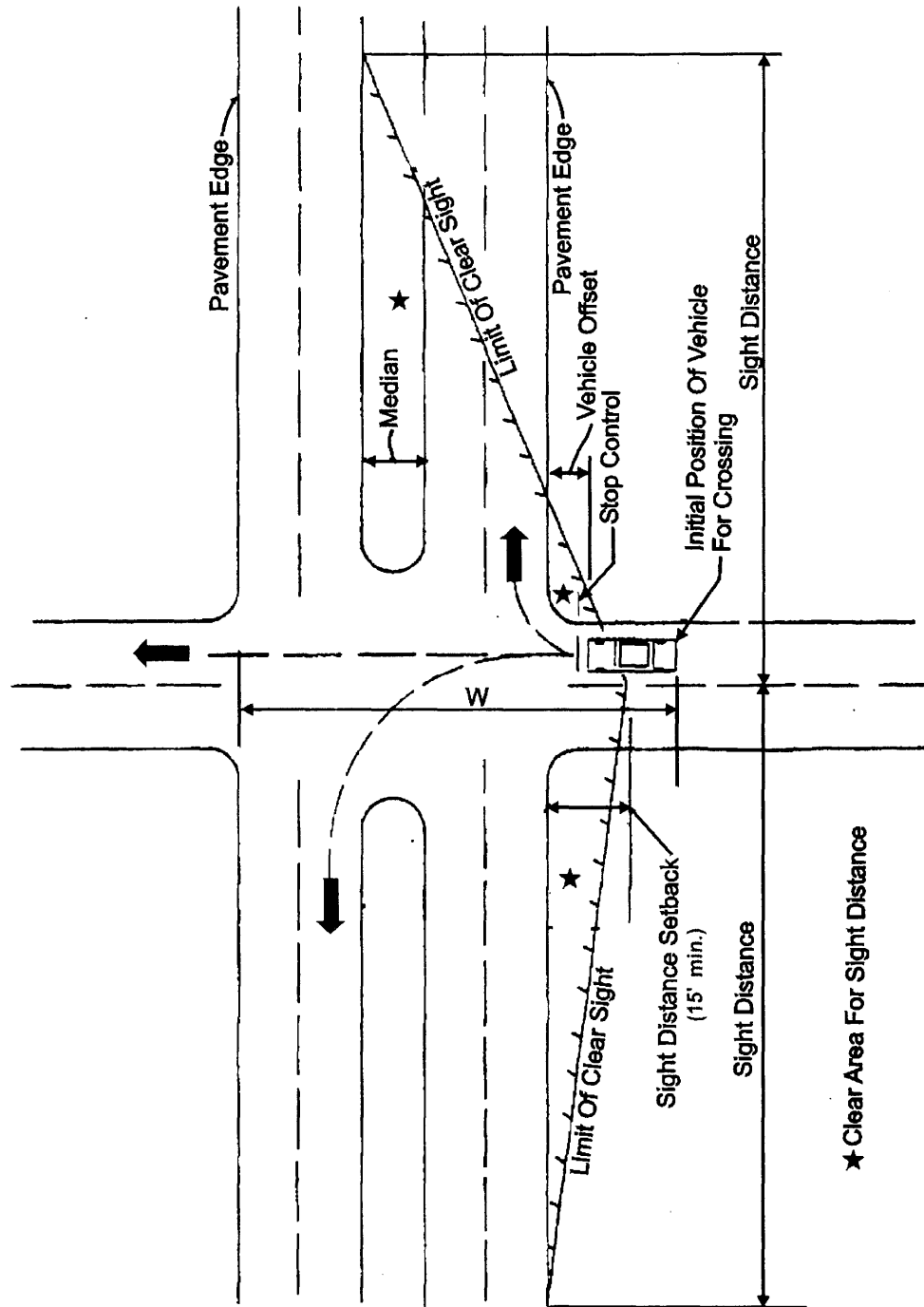
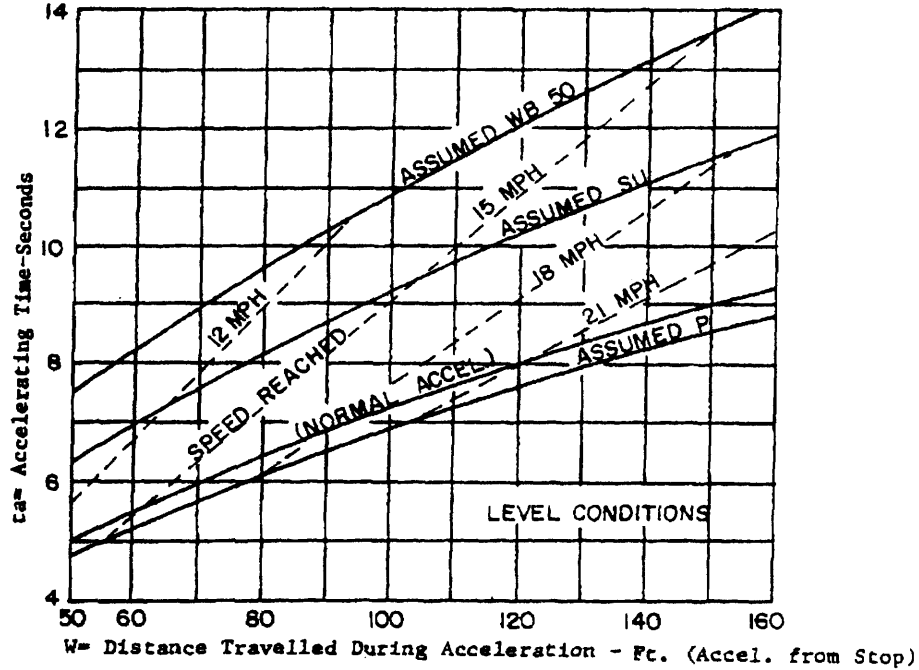

FIGURE 3 - 12
 SIGHT DISTANCE AT INTERSECTIONS



For WB-40 design vehicles, use WB-50 curve.

For Bus design vehicles, use SU

The sight distance required to allow the design vehicle to cross the intersection is computed from the following formula:

$$d = 1.47 V (J + t_a)$$

d = minimum sight distance along the major highway (ft.)

V = design speed of major highway (MPH)

J = driver reaction time (Assumed as 2 sec.)

t_a = Maneuver time determined from the graph.

Design Vehicle	Adjustment factor for t_a , based on crossing grade rate				
	-4%	-2%	0%	+2%	+4%
P	0.7	0.9	1	1.1	1.3
SU & Bus	0.8	0.9	1	1.1	1.3
WB - 50	0.8	0.9	1	1.2	1.7

FIGURE 3 - 13
TERMINATION OF MERGING LANES

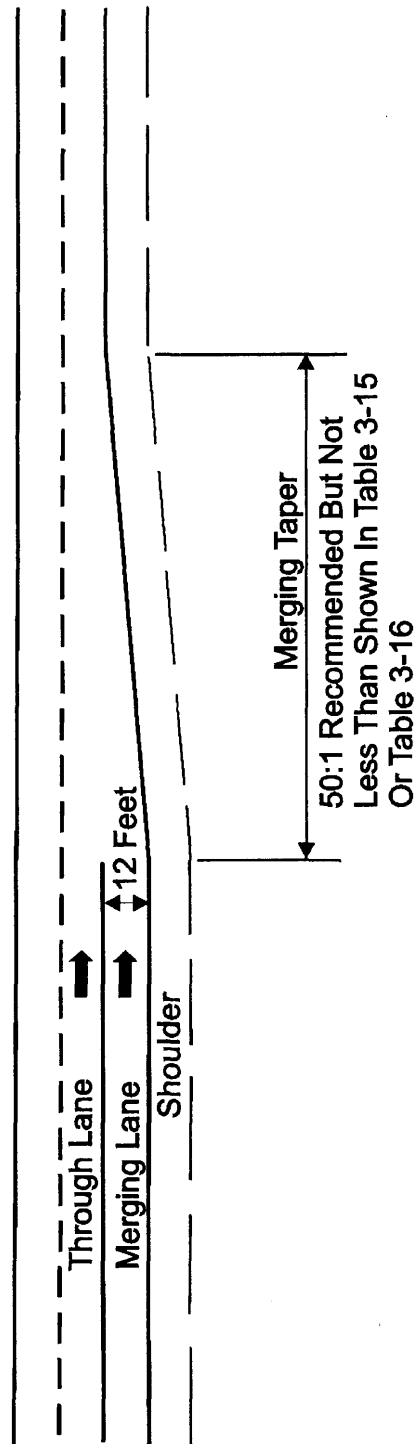

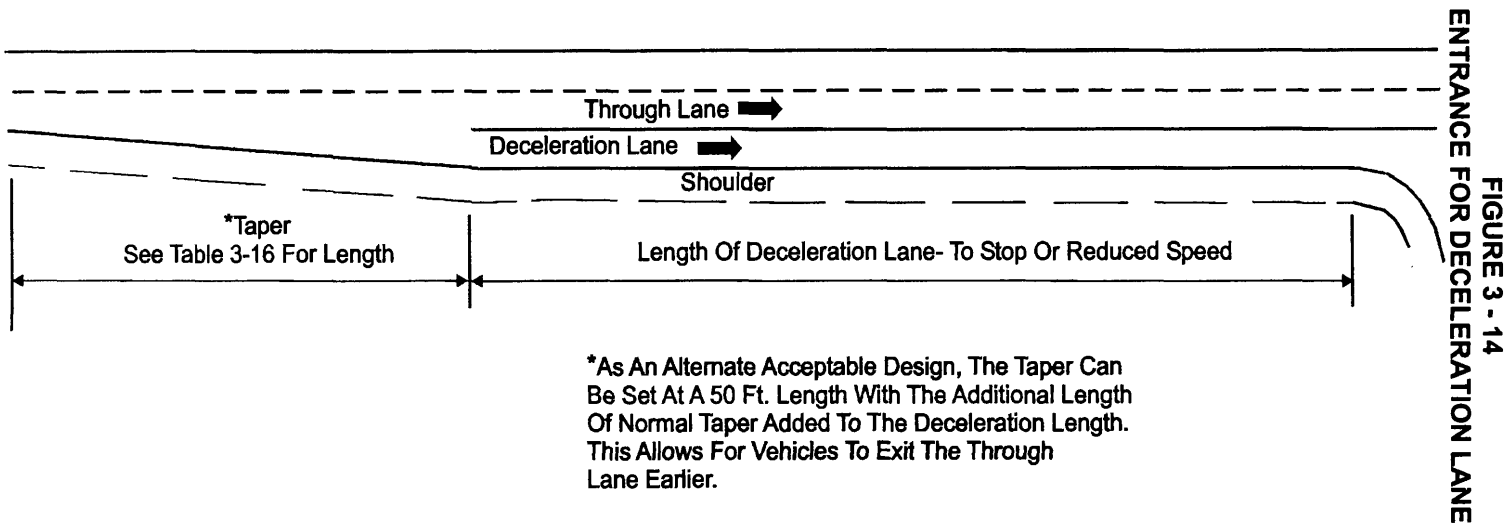

*As An Alternate Acceptable Design, The Taper Can Be Set At A 50 Ft. Length With The Additional Length Of Normal Taper Added To The Deceleration Length. This Allows For Vehicles To Exit The Through Lane Earlier.

**FIGURE 3 - 15
 TYPICAL STORAGE LANE**

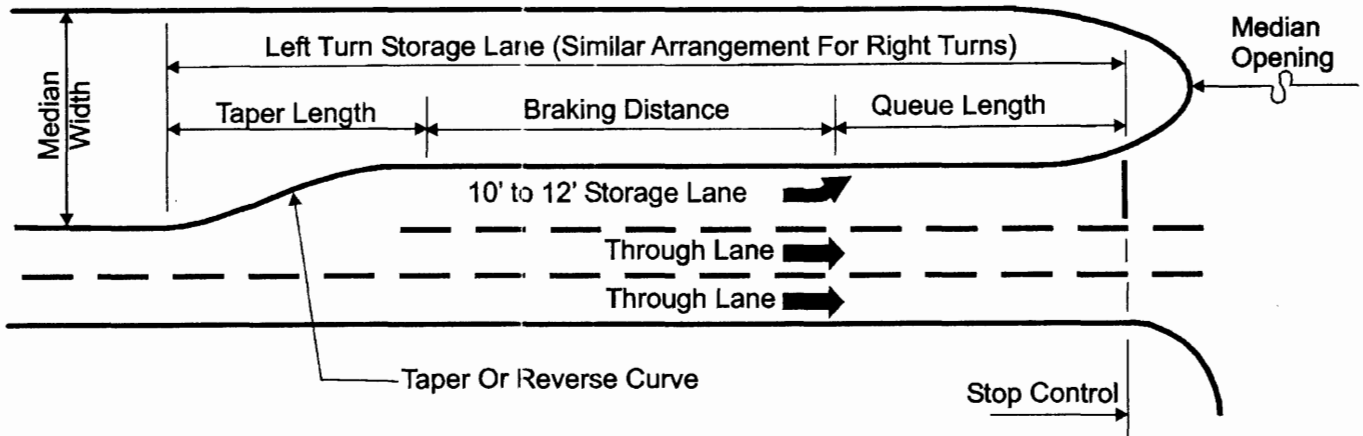

Storage Queue Length - Unsignalized Intersections

Turning Vehicles Per Hour	30	60	100	200	300
Required Storage Length, Feet	25	50	100	175	250

At signalized intersections the required queue length depends on the signal cycle length, the signal phasing arrangement, and rate of arrivals and departures of turning vehicles.

In absence of a turning movement study, it is recommended that 100 ft. of queue length be provided in urban/suburban areas and 50 ft. of queue length be provided in rural/ town areas as a minimum.

Taper Length And Braking Distance, Feet

Highway Design Speed	Storage Entry Speed*	Taper Length	Brake To Stop	
			Urban**	Rural***
35	25	70	75	
40	30	80	75	
45	35	85	100	
50	40/44	105	135	215
55	48	125		260
60	52	145		310
65	55	170		350

* Reaction Precedes Entry
 **Minimum Braking Distance, Wet Conditions
 ***Customary Braking Distance, Wet Conditions

The storage lane may be in place of or in addition to deceleration length (See Section 3-9.c.3.b C.9.c.3).

**FIGURE 3-16
 STANDARD HS-20 TRUCKS**

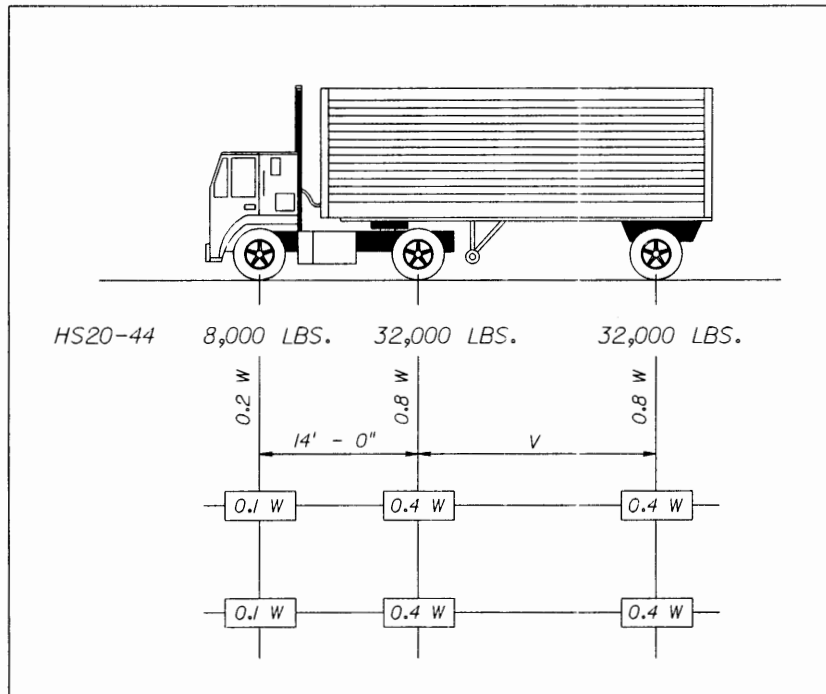

W = COMBINED WEIGHT ON THE FIRST TWO AXLES.
 V = VARIABLE SPACING - 14 FEET TO 30 FEET INCLUSIVE. SPACING TO BE USED IS THAT WHICH PRODUCES MAXIMUM STRESSES.

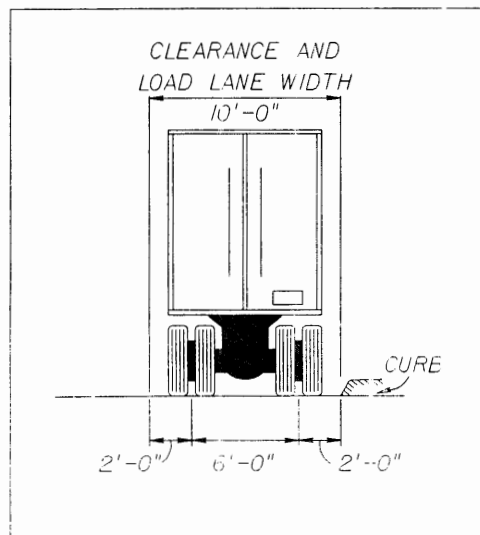

**FIGURE 3-17.
LANE LOADING**

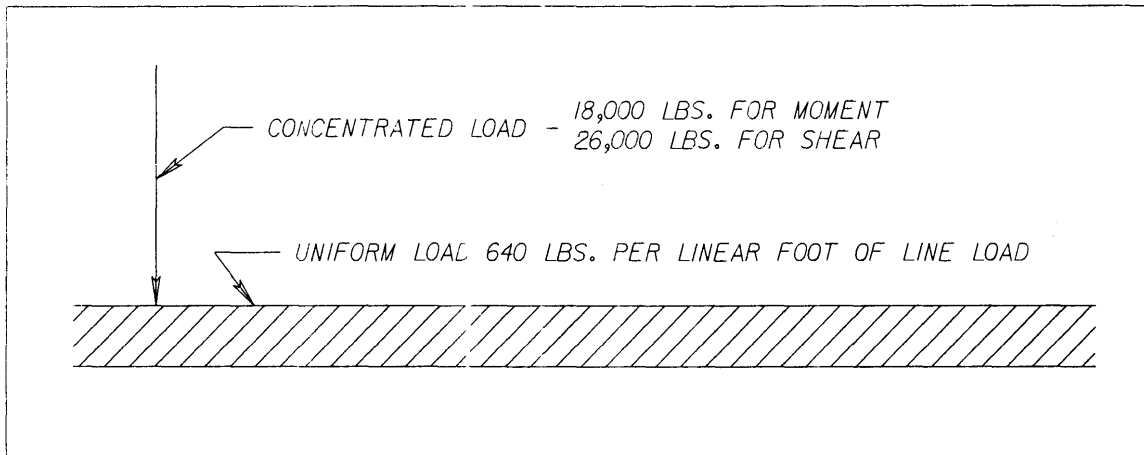

HS-20 Loading



CHAPTER 4

ROADSIDE DESIGN

A. INTRODUCTION

This chapter presents guidelines and standards for roadside designs intended to reduce the likelihood and/or consequences of roadside crashes. Construction and maintenance of safe medians and roadsides are of vital importance in the development of safe streets and highways.

Many of the standards presented in CHAPTER 3 - GEOMETRIC DESIGN are predicated to a large extent upon reducing the probability of vehicles leaving the proper travel path. Other standards in that chapter are directed toward a reduction in the likelihood and/or consequences of crashes by vehicles leaving the roadway. These standards contain requirements for the design of shoulders, medians, and roadsides including requirements for the use of guardrail and barriers. Design of the roadside should be considered and conducted as an integral part of the total highway design.

Due to the variety of causative factors, the designer should consider a vehicle leaving the traveled way at any location. Design of the roadside should be based upon reducing the consequences to errant vehicles and their occupants.

B. POLICY

The roadside, which includes the median, shall be considered as the total environment adjacent to the roadway. The design of the roadside shall be considered as an integral part of the total highway design.

C. OBJECTIVES

General objectives to be followed in roadside design are to provide an environment that will reduce the likelihood and/or consequences of crashes by vehicles that have left the traveled way. The achievement of this general objective will be aided by the following:

- Roadside areas adequate to allow reasonable space and time for a driver to regain or retain control of the vehicle and stop or return to the traveled way

- Shoulders, medians, and roadsides that may be traversed safely without overturning
- Location of roadside objects and hazards as far from the travel lane as is economically feasible
- Roadsides that, in addition to being safe, appear safe to the driver to encourage use of the roadside for necessary emergency maneuvers and for emergency parking
- Protection of pedestrians, workmen, or other persons subjected to the hazard of out-of-control vehicles.
- Adequate protective devices (where hazards are unavoidable) compatible with vehicle speeds and other design variables.

D. ROADSIDE DESIGN

The basic requirements and standards for the design of shoulders, medians, and roadsides are given in CHAPTER 3 - GEOMETRIC DESIGN. This includes specific requirements regarding widths, slopes, and changes in grade. General requirements for drainage facilities, utilities, transit, and pedestrian facilities are also included.

This chapter contains general guidelines for particular situations encountered in roadside design due to the variety and complexity of possible situations encountered. The designer should utilize the following as basic guidelines to develop a safe roadside design.

D.1. Geometric Changes

D.1.a. Horizontal Curves

On horizontal curves, consideration should be given to increasing the median and roadsides above the minimum requirements due to the increased likelihood of vehicles leaving the traveled way. Increasing widths and decreasing slopes on curves is also important since a vehicle will probably leave the traveled way at a steeper exit angle. Increasing widths on curves is also beneficial in improving the available sight distance.

D.1.b. Vertical Curves

As a vehicle comes over a crest, the driver may suddenly be presented with a situation requiring an emergency maneuver. The provision of adequate clear zones is particularly important where traffic volumes are high (i.e., urban areas) since traffic queues may form rapidly, thus tending to cause rear-end collisions.

D.1.c. Changes in Cross Section

The provision of adequate clear zone is very important at exits, entrances, lane drops, or other changes in the roadway cross section. The exterior boundaries of the clear zone should extend well beyond any reductions in roadway width and then gradually reduce to provide design width for the new roadway cross section.

D.1.d. Decision or Conflict Points

Adequate clear zones should be provided at any point of traffic merging or conflicts, and at locations where the driver is confronted with making a decision regarding vehicle maneuvers.

D.2 Fills

Many roadways, for drainage purposes, are elevated somewhat above the surrounding terrain. Where feasible, the side slopes should not exceed a ratio of 1:4. On flatter slopes (1:6 or greater), care should be exercised to eliminate sharp changes in grade or other discontinuities.

If the side slope is steeper than 1:3, guardrail or another longitudinal barrier should be considered.

D.3 Cuts

A primary objective of roadside design in cut sections is to prevent conditions tending to cause rollovers or serious collisions with the cut slopes. When the material (soils) in the cut is smooth and stable, the use of an increasing backslope is a reasonable solution. The technique is also acceptable in stable rock cuts, provided that smooth fill material is utilized to effect the backslope.

The use of a rigid barrier incorporated into the cut slope is also satisfactory for rock slopes. Where the material in the cut is irregular or unstable, a guardrail or other longitudinal barrier set out from the cut face should be utilized. Placing the barrier away from the slope is necessary to prevent rocks or other materials from falling onto the roadsides.

D.4 Roadside Canals

Roadside canals or other bodies of water close to the roadway should be eliminated wherever feasible.

Where roadside bodies of water (with seasonal water depth in excess of 3 feet for

24 hours or longer) lie within the roadside clear zone, they shall be guarded.

D.5 Vegetation

The proper use of natural vegetation can provide valuable and economical assistance in developing aesthetic and safe roadsides.

D.5.a. Stability

The use of grass or other easily maintained, low-growing vegetation may be used on medians and roadsides. This vegetation should be carefully maintained so vehicles can safely traverse those areas.

D.5.b. Drainage

Drainage swales may be protected from hazardous scouring (alteration of safe ditch contour) by the appropriate vegetation. Grass, vines, or other plants can be beneficial in stabilizing embankments to prevent erosion of material onto adjacent roadways. The appropriate use of grass or shrubbery can also aid in retarding runoff in the vicinity of the roadway, thus benefitting the overall drainage pattern.

D.5.c. Crash Cushions

Native shrubbery may also be used as an effective natural barrier or crash cushion at the outer edge of the clear roadsides. Care should be taken to use shrubbery or other vegetation that would slow an out-of-control vehicle without excessive deceleration. Vegetation that would develop large trunks or branches should be avoided.

D.5.d. Environmental and Aesthetic Considerations

The use of natural grass and shrubbery for borders along roadways provides an important environmental asset. This border serves as a preserved green belt that minimizes the adverse impact (dirt, noise, etc.) of a street or highway. The use of a wide, gently flowing grassed roadside of varying width is generally an aesthetically pleasing solution to safe roadside design.

D.5.e. Landscaping - Design Considerations

The Roadway and Traffic Design Standards published by the FDOT (Index Numbers 544 and 546), contain information on landscaping, that may be considered. Index 544 provides landscape installation details, and Index 546 provides information on landscaping in vicinities of intersections. FDOT also produces the "Florida Highway Landscaping Guide" which is an excellent

landscaping information source.

D.6 Drainage

Proper drainage of the pavement, shoulders, median, and roadsides is important for maintaining a safe street or highway. Techniques utilized for providing drainage should result in safe vehicle operation on or off the roadway.

D.6.a. Inlets

Drainage inlets should not be placed in a bus bay, travel, or bike lane and should not be placed in a shoulder, except at the exterior edge, when drainage restrictions are severe. Drainage inlets within the median or roadsides shall be traversable. A small area around the inlet should be paved to improve drainage and to prevent local erosion. Corner radii inlets should be avoided as they hinder pedestrians, create ponding, create maintenance problems, and complicate intersection design.

D.6.b. Ditches

Drainage ditches perpendicular to the roadway should not be used within the median or roadsides. All drainage ditches within the median or roadsides shall meet the requirements for slopes and changes in grade given in CHAPTER 3 - GEOMETRIC DESIGN.

D.6.c. Culverts

At intersections, exits, entrances, driveways, and median crossovers, the drainage flow pattern should, if possible, be directed away from the median or roadsides.

Where culverts are unavoidable at intersections, the entrance and exit should be flush with the adjacent ground or located beyond the clear zone. The slope and changes in grade at the structure should conform to minimum requirements for roadsides. Culvert terminations at median crossovers should be constructed in a similar fashion.

Where culverts are required perpendicular to the roadway, they should be extended to the roadsides as a minimum. Headwalls at the culvert terminations (within the clear zone) should not protrude above the ground surface in excess of 4 inches. Sloping entrances and exits generally flush with side slopes should be used wherever possible (even outside the clear zone). Proper ground contouring of the roadside approach can provide a relatively smooth surface that can be traversed with reasonable safety by an out-of-control vehicle.

D.7 Curbs

The basic criteria for prohibiting or permitting the use of curbs is given in CHAPTER 3 - GEOMETRIC DESIGN. Curbs serve any or all of the following purposes: drainage control, roadway edge delineation, right-of-way reduction, aesthetics, delineation of pedestrian walkways, reduction of maintenance operations, and assistance in orderly roadside development.

Curbs should not be used along freeways or other high-speed arterials, but if a curb is needed, it should not be located closer to the traveled way than the outer edge of the shoulder. In addition, sloping-end treatments should be provided.

D.8 Poles and Support Structures

The location and design of poles or support structures for signs, signals, lighting, or other purposes is an important aspect of safe roadside design. All poles and support structures should be located outside the required clear zone when practical unless their supports are of the frangible or breakaway type. When practical, poles and sign supports should be located behind existing barriers.

The function of a breakaway support is to minimize the vehicle deceleration and the probability of injury to the vehicle occupants. The design of the support should also be adequate to prevent portions of the structure from penetrating the vehicle interior.

Small signs should be designed to bend over flush with the ground upon impact. Larger signs should be designed with multiple posts with slip joints at the base and a weakened section and fuse plate intended to act as a hinge at the bottom of the sign.

Utility poles and structures not related to highway operations, should be located outside the clear zone and as close as practical to the edge of right of way, without aerial encroachment, and without violating National Electric Safety Code (NESC) clearances. New utility poles not placed at the edge of the right of way, and falling within the limits of the clear zone dimensions defined in Table 3-12 should be approved through the exception process prescribed in Chapter 14 - DESIGN EXCEPTIONS. Placement within sidewalk shall be such that a minimum unobstructed sidewalk width of 32" is provided.

In accordance with Section 337.403, Florida Statutes, existing utility poles must be relocated when **unreasonably** interfering with the "convenient, safe, or continuous use, or the maintenance, improvement, extension, or expansion" of public roads. Utility poles adjacent to road improvement projects, but not directly interfering with construction, within the limits of the Control Zones depicted in FDOT's January 1999 Utility Accommodation Manual (Rule 14-46.001), Exhibit H should be considered for

relocation, to the extent they can be relocated, to achieve the clear zone requirements of Table 3-12. Utility poles that cannot be relocated and will remain within the limits of a Control Zone, should be approved through the exception process prescribed in Chapter 14 - DESIGN EXCEPTIONS.

D.9 Intersections

All poles or other structures not absolutely essential should not be located in the vicinity of the intersection. When joint use agreements can be arranged, the various governmental agencies, transit authorities, and utilities should consider the use of joint purpose single poles as a replacement for all poles or structures serving a single purpose. Light poles, traffic signal supports and boxes, transit stop signs, and all other street furniture should be moved back as far as is practical from the boundary of the roadsides.

Energy absorbing devices should be considered for protection of lighting and traffic signal supports located within the roadsides.

D.10 Underpasses

The full median and roadside should be carried through underpasses without interruption. Where it is not feasible to eliminate the supports, guardrail or another longitudinal barrier should be used. The barrier may be a rigid barrier incorporated into the support columns or a guardrail set out from the supports. The barrier should be extended well beyond the supports.

D.11 Bridges and Overpasses

The required horizontal clearance (CHAPTER 3 - GEOMETRIC DESIGN) should be maintained on all bridges, overpasses, or other elevated roadways. The full roadway cross section, including shoulders, should be carried across without interruption. Bridge railings should be designed and constructed in compliance with the requirements for redirection barriers. Particular emphasis should be placed on the prevention of structural failure and vaulting of the railing by errant vehicles.

On all high speed roadways (design speed 50 mph or greater), the bridge railing or other barriers should be extended sufficiently (and properly terminated) to prevent vehicles from passing behind the barrier and entering the hazardous location. The transition between the bridge railing and the approach barrier should be smooth and continuous. Barrier curbs should not be placed in front of bridge railings or other barriers. Pedestrian facilities should be placed outside of the bridge railing or barrier on all high speed roadways.

It is desirable that twin bridges for nominal width median divided highways be filled in the dividing area, carrying the median across the bridge without interruption. The

gore area between diverging elevated roadways should be bridged over for a sufficient distance to allow for the placement of any energy absorbing devices. If twin bridges are used, the median layout should conform to CHAPTER 3 - GEOMETRIC DESIGN.

D.12 Mailboxes

Guidelines for the location of mailboxes, type of support and turnout construction, given in Standard Index 532 or "A Guide for Erecting Mailboxes on Highways" (AASHTO), should be considered.

D.13 Bus Shelters

Bus shelters should be moved back as far as practical from the roadside with pedestrian access to the passenger pad at the roadside. Proper marking by color and surface texture is essential for convenience and safety of pedestrians.

E. PROTECTIVE DEVICES

Protective devices for roadside design may be considered as highway appurtenances intended to reduce the severity of off-the-road accidents. In those situations where the minimum safety standards for median and roadside are not feasible, protective devices should be considered. Guardrail and crash cushions should not be used indiscriminately, for at least two reasons: they are expensive to install and maintain, and they are closer to the road than the objects they are shielding. They are involved in more accidents than unshielded objects. They should be used only when they are warranted by the reduction in accident severity.

E.1 Redirection Devices

Redirection devices are longitudinal barriers (rigid or flexible) such as guardrails, median barriers, and bridge railings placed parallel to the roadway to contain and redirect out-of-control vehicles.

E.1.a Function

The primary function of a longitudinal barrier is to redirect an errant vehicle away from hazardous roadside situations. The barrier should be designed to produce a minimum of deceleration (lateral and longitudinal) to a vehicle.

E.1.b Warranting Conditions

Warranting conditions for the use of longitudinal barriers are essentially those conditions in which the overall probability of injuries and fatalities

would be reduced by the use of these redirection devices.

E.1.c. Location

Ideally, the barrier should be located to minimize the likelihood of being struck by an errant vehicle. The barrier should be located outside the normal shoulder width. The location and orientation of the barrier should also be selected to minimize the angle of impact and the resulting vehicle deceleration.

Flexible barriers should be set out from rigid objects or other hazards a sufficient distance so the barrier may deflect without interference. Reasonable deflections for guardrails with strong posts are approximately 2 to 4 feet. Weak-post/strong-posts rail barriers and cable systems may deflect considerably more. The location of the barrier should be selected in close coordination with the design of its deflection characteristics.

E.1.d. Length

The length of a longitudinal barrier should be sufficient to prevent a vehicle, traveling in either direction, from passing behind the barrier and striking the hazard being guarded.

E.1.e. Vehicle Containment

Longitudinal barriers should have sufficient strength to prevent a vehicle from breaking through the barrier. Structural continuity and smoothness is also required to prevent rapid deceleration or penetration of the vehicle by any of the barrier components. The shape and height of the barrier should be adequate to deter overturning or vaulting of the vehicle. The surface in front of the barrier should be approximately perpendicular to the barrier and should be free from barrier curbs or other discontinuities.

E.1.f. Barrier Types

Barriers may be generally classified as rigid or flexible. The recommended barriers in the following sections are intended as general guidelines only. As new types of barriers are developed and tested successfully, they may be incorporated into roadside design. They should, however, conform with the requirements previously established.

- Rigid Barrier - Rigid barriers are generally less effective in controlling lateral vehicle deceleration at locations subject to high-angle impacts. The use of this barrier is recommended for bridge railings and for use at retaining walls, rock cuts, or

other rigid hazards where space limitations are severe.

- Flexible Barrier - Barriers which yield somewhat on impact are often more useful in limiting the rate of vehicle deceleration. Special care should be exercised to ensure they are structurally adequate and they maintain a smooth continuous surface.

This type of barrier can be expected to deflect 2 to 4 feet under impact. The post spacing may be increased when a stiffer rail is utilized. The weak post barrier and the cable barrier can be expected to deflect 8 to 12 feet or more and should be limited to locations with adequate clear space.

E.1.g. Transitions

Changes in barrier types should be kept to a minimum. Transitions between two types of barriers should be smooth and continuous with no protruding components that could snag or penetrate a vehicle striking the barrier from either direction. The transition from a flexible to a rigid barrier should be stiffened gradually to prevent "pocketing" of an errant vehicle.

E.1.h. Terminations

Barrier terminations or interruptions should be kept to a minimum. The barrier termination should be designed to allow for a reasonably safe traversal by a vehicle traveling in either direction.

Roadside guardrails should be flared away from the roadway. The use of energy absorbing devices as the termination of the longitudinal barrier is an effective and acceptable procedure for both roadsides and medians.

E.2 Energy Absorbing Devices

E.2.a. Function

The primary function of an energy absorbing device or crash cushion is to limit the deceleration rate of a vehicle. These are utilized at locations where impact with the roadside object would produce a greater deceleration rate. The deceleration rate is controlled by providing a cushion which deforms over a large distance while bringing the vehicle gradually to a stop.

E.2.b. Warranting Conditions

Crash cushions (or other protective devices) are used for the protection of occupants of an out of control vehicle which might strike objects in the median or roadside that would produce serious vehicle deceleration.

Other locations or situations that should be considered for crash cushions include:

- Gore areas on elevated roadways
- Intersections
- Barrier terminations
- Bridge abutments and supports
- Retaining walls
- Any other roadside object subject to impact by an errant vehicle

E.2.c. Design Criteria

The primary design criteria is the limitation of vehicle deceleration which is a function of the vehicle speed and the total crash cushion deformation.

The crash cushion should be located as far from the roadway as is practicable to reduce the likelihood of impact. Special care should be exercised in the design to reduce the probability of a vehicle overturning or vaulting the crash cushion.

E.2.d. Design Details

The development and testing of crash cushions are both recent and rapid. The rapidly expanding technology in this field requires the most recent research and experience be utilized in selecting a particular type of crash cushion.



CHAPTER 5

PAVEMENT DESIGN, CONSTRUCTION, AND MAINTENANCE

A. INTRODUCTION

The function of the pavement or roadway surface is to provide a safe and efficient travel path for vehicles using the street or highway. The pavement should provide a good riding surface with a minimum amount of distraction to the driver. The pavement friction characteristics should be such that adequate longitudinal and lateral forces between the vehicle tires and the pavement can be developed to allow a margin of safety for required vehicle maneuvers. These characteristics should be provided at the highest reasonable level for the expected pavement surface, weather conditions, and the anticipated operational characteristics of the facility.

In order for the pavement to perform its function properly, the following objectives shall be used to guide the design and construction of the pavement:

- Provide sufficient pavement structure and the proper pavement material strength to prevent pavement distress prior to the end of the design period
- Develop and maintain adequate skid resistance qualities to allow for safe execution of braking, cornering, accelerating, and other vehicle maneuvers
- Provide drainage to promote quick drying and to reduce the likelihood of hydroplaning and splashing

B. PAVEMENT DESIGN

B.1. Pavement Type Selection

For new construction and major reconstruction projects, the designer should determine the type of pavement to be constructed utilizing formal analysis of existing and anticipated conditions. The FDOT has a documented procedure patterned after the 1986 AASHTO Guide for Design of Pavement Structures,

Appendix B. This procedure may be found in FDOT Flexible Pavement Design Manual.

B.2. Structural Design

The pavement shall be designed and constructed so the required surface texture is maintained and its structure retains an adequate level of serviceability for the design period. The strength of the pavement materials shall be sufficient to maintain the desired roadway cross section without the formation of ruts or other depressions which would impede drainage. Subgrade strength and subgrade drainage are major factors to be considered in pavement design.

The FDOT pavement design manuals are recommended as a guide for both flexible and rigid pavement design. Other design procedures are available including the AASHTO Guide for Design of Pavement Structures, 1986; the AASHTO Interim Guide for Design of Pavement Structures, 1972; and procedures which have been developed by the Portland Cement Association, the American Concrete Pavement Association, and the Asphalt Institute. The selection of the design procedure and the development of the design data must be managed by professional personnel competent to make these evaluations.

B.3. Skid Resistance

Pavements shall be designed and constructed so as to maintain adequate skid resistance for as long a period as the available materials, technology, and economic restraints will permit, thus eliminating cost and hazardous maintenance operations.

The results of relevant experience and testing (i.e., tests conducted by FDOT Materials Office) should be used in the selection of aggregate and other materials, the pavement mix design, the method of placement, and the techniques used for finishing the pavement surface. The design mixes should be monitored by continuous field testing during construction. Changes to the design mix or construction procedures must be made by qualified pavement designers and laboratory personnel ONLY.

B.4. Drainage

Adequate drainage of the roadway and shoulder surfaces should be provided. Factors involved in the general pavement drainage pattern include: pavement longitudinal and cross slopes, shoulder slopes and surface texture, curb placement,

and the location and design of collection structures. The selection of pavement cross slopes should receive particular attention to achieve the proper balance between drainage requirements and vehicle operating requirements. The use of curbs or other drainage controls adjacent to the roadway surface should be avoided, particularly on high speed facilities. Specific requirements for cross slopes and curb placement are given in CHAPTER 3 - GEOMETRIC DESIGN.

The use of grooving (across the roadway) in concrete pavements frequently improves the wet weather skid resistance and decreases the likelihood of hydroplaning. This technique should be considered for locations requiring frequent vehicle maneuvers (curves, intersections, etc.) or where heavy traffic volumes or high speeds will be encountered. The depth, width, and spacing of the grooves should be such that vehicle operations are not hindered.

B.5. Shoulder Treatment

The primary function of the shoulder is to provide an alternate travel path for vehicles in an emergency situation and preferred path for bicyclists. Shoulders should be capable of providing a safe path for vehicles traveling at roadway speed, and should be designed and constructed to provide a firm and uniform surface capable of supporting vehicles in distress. Particular attention should be given to providing a smooth transition from pavement to shoulder and avoiding hazardous "drop-offs."

Paved shoulders may be provided to improve drainage of the roadway, to serve bicycles and transit users, and to minimize shoulder maintenance.

C. PAVEMENT CONSTRUCTION

A regular program of inspection and evaluation should be conducted to ensure the pavement criteria are satisfied during the construction process. Any regular inspection program should include the following:

- The use of standard test procedures, such as AASHTO and the American Society for Testing and Materials (ASTM)
- The use of qualified personnel to perform testing and inspection
- The use of an independent assurance procedure to validate the program

After construction, the pavement surface shall be inspected to determine the required surface texture was achieved and the surface has the specified slopes. Spot checking of skid resistance by approved methods should be considered. Inspection of the roadway during wet weather conditions should be carried out as soon as possible to quickly locate drainage problems such as depressions in the pavement surface. Periodic reinspection should be undertaken in conformance with the guidelines described under Pavement Maintenance.

D. PAVEMENT MAINTENANCE

The primary purpose of pavement maintenance is to ensure the pavement characteristics prescribed in paragraphs B and C, Pavement Design and Pavement Construction, are reasonably maintained. Each agency with responsibility for maintenance of streets and highways should establish a meaningful pavement maintenance system (including shoulders and drainage structures) for the entire system under its jurisdiction. This program should include:

- A process that monitors the serviceability of the existing streets and highways and identifies the pavement sections that are inadequate
- A systematic plan of maintenance activities designed to correct structural deficiencies and to prevent rapid deterioration
- A preservation program, with assigned priorities, designed to resurface, reconstruct, or replace pavements when they are no longer structurally serviceable

Pavement maintenance requires a substantial portion of the total maintenance budget for streets and highways. It is necessary to ensure highway safety. A smooth-riding, skid-resistant surface must be provided at all times to allow for safe vehicle maneuvers. The reduction of hydroplaning and splashing is essential for promoting safe and efficient operation during wet weather conditions. The elimination of driving discomfort, and vehicle damage caused by deteriorated pavements, provides additional economic justification for maintaining the pavement in a fully serviceable condition.

It is recognized that a comprehensive preservation program is expensive. Adequate financing is required to successfully carry out these activities. The establishment of appropriate budget priorities and careful planning can assist in developing and conducting a pavement maintenance and preservation program that will, within a reasonable number

of years, bring substandard pavements up to the required level of serviceability and will maintain the adequacy of the entire system.

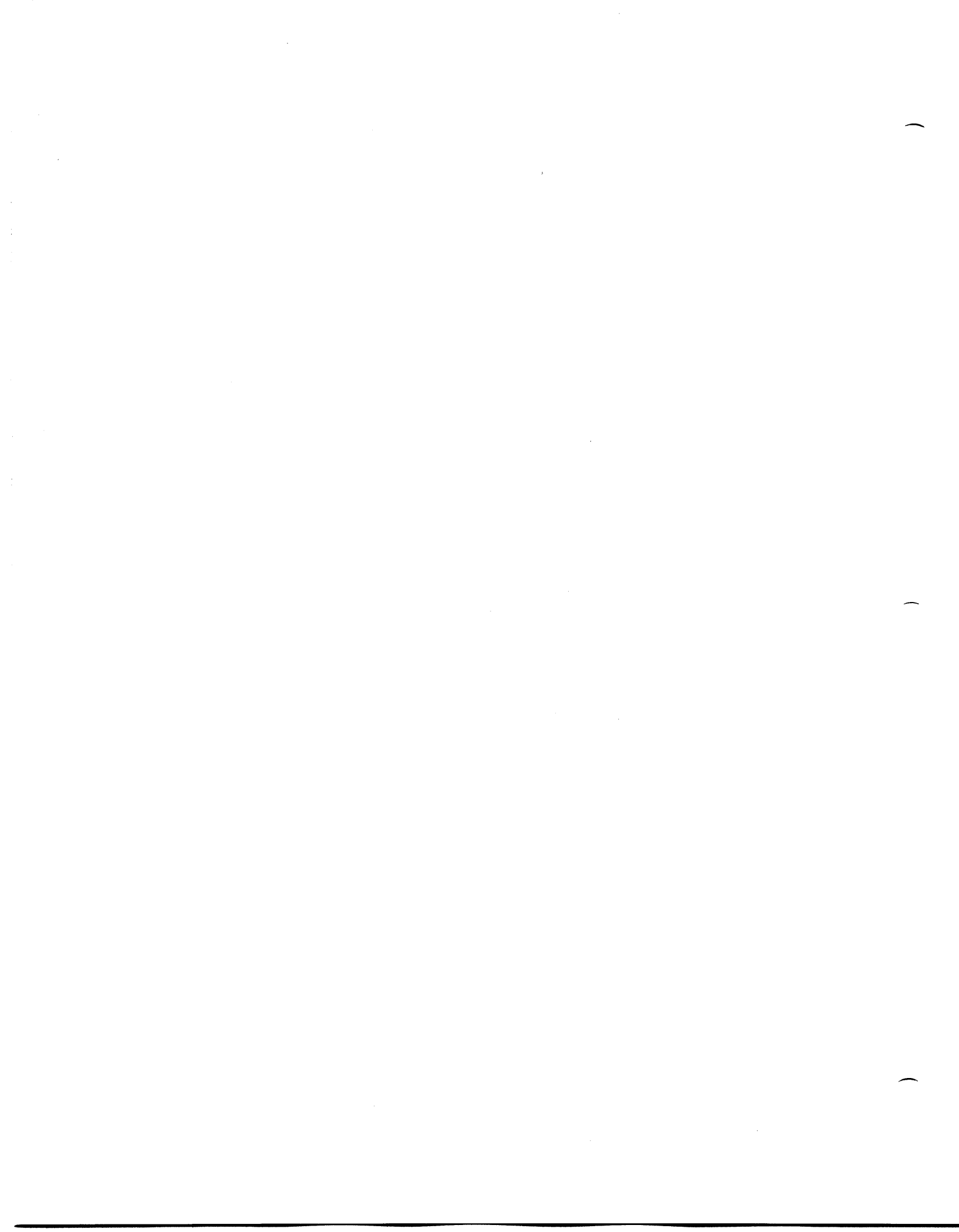

CHAPTER 6

ROADWAY LIGHTING

A. INTRODUCTION

The major reason for lighting streets and highways is to improve safety for vehicular and pedestrian traffic. Improvements in sight distance and reduction of confusion and distraction for night time driving can reduce the hazard potential on streets and highways. There is evidence indicating that highway lighting will produce an increase in highway capacity as well as improve the economic, safety, and aesthetic characteristics of highways.

Experience and technical improvements have resulted in improved design of lighting for streets and highways. Photometric data provide a basis for calculation of the illumination at any point for various combinations of selected luminaire types, heights, and locations. Lighting engineers can develop a lighting system that will comply with the requirements for level and uniformity of illumination; however, some uncertainties preclude the adoption of rigid design standards. Among these uncertainties is the lack of understanding in the area of driver response and behavior under various lighting conditions. The design of lighting for new streets and highways, as well as improvements on existing facilities, should be accompanied by careful consideration of the variables involved in driver behavior and problems peculiar to particular locations.

B. OBJECTIVES

The objective for providing roadway lighting is the reduction of particular hazards confronting motorists and pedestrians on the roadway. The achievement of this objective will be aided by meeting these specific objectives:

- Provide the driver with an improved view of the general roadway geometry and the adjacent environment
- Increase the sight distance of drivers to improve response to hazards and decision points
- Improve the mutual view of motorists and pedestrians

- Eliminate "blind" spots peculiar to night driving
- Provide a clearer view of the general situation during police, emergency, maintenance, and construction operations
- Provide assistance in roadway delineation, particularly in the presence of confusing background lighting (i.e., surrounding street and other area lighting confuses the driver on an unlighted street or highway)
- Eliminate glare that is discomforting or disabling to the driver
- Avoid abrupt changes in light intensity
- Provide maintenance capabilities and procedures that will minimize hazards to motorists
- Avoid the introduction of roadside hazards resulting from improper placement of light poles (as covered under Geometric Design and Roadside Design)

C. WARRANTING CONDITIONS

Although precise warrants for provision of roadway lighting are difficult to determine, criteria for lighting is established and should be followed for construction and for improvement of existing facilities. The following locations should be considered as a basis for warranting roadway lighting:

C.1. Criteria Based Upon Accident History

- Locations where pedestrians assemble to board transits
- Locations that, by an accident investigation program, have been shown to be hazardous due to inadequate lighting
- Locations where the night/day ratio of serious crashes is higher than the average of similar locations
- Specific locations that have a significant number of night time crashes and where a large percentage of these night time crashes result in injuries or fatalities

C.2. Criteria Based Upon Analysis and Investigation

- Locations requiring a rapid sequence of decisions by the driver
- Locations where night sight distance problems exist, with particular consideration to vehicle headlight limitations (i.e., where vertical and horizontal curvature adversely affect illumination by headlamps)
- Locations having discomforting or disabling glare
- Locations where background lighting exists, particularly if this could be distracting or confusing to the driver
- Locations where improved delineation of the roadway alignment is needed

C.3. General Criteria

- Freeways, expressways, and major streets and highways in urban areas
- Freeways with frequent ($\frac{1}{2}$ mile from "on" ramp to "off" ramp) interchanges
- Freeways with high volume and speed
- Freeway interchanges including ramps and approach roadways
- Acceleration and deceleration lanes
- Rest areas
- Junctions of freeways and major highways in rural areas
- Urban collector streets, particularly with high speed, high volumes, or frequent turning movements
- Urban streets of any category experiencing high night time volumes or speeds or that have frequent signalization or turning movements
- Areas frequently congested with vehicular and/or pedestrian traffic
- Pedestrian crossings, entertainment districts, sporting arenas, and other locations that attract volumes of pedestrian activity

- Schools, churches, bus stops, or other pedestrian or bicycle generators
- High density land use areas
- Central business district

D. LEVEL OF ILLUMINATION

It is recommended that the level of illumination for streets and highways not be less than:

- Levels consistent with need and resources
- Guidelines established by AASHTO - An Informational Guide for Roadway Lighting

These levels are for the purpose of highway safety and do not apply to lighting levels required for crime reduction.

E. UNIFORMITY OF ILLUMINATION

In order to avoid vision problems due to varying illumination, it is important to maintain illumination uniformity over the roadway. It is recommended the ratio of the average to the minimum initial illumination on the roadway be between 3:1 to 4:1.

A maximum to minimum uniformity ratio of 10:1 should not be exceeded. It is important to allow time for the driver's eye to adjust to lower light levels. The first poles should be located on the side of the incoming traffic approaching the illuminated area. The eye can more quickly adjust to increased or increasing light level. In transition from a lighted to an unlighted portion of the highways, the level should be gradually reduced from the level maintained on the lighted section. This may be accomplished by having the last pole occur on the opposite roadway. The roadway section following lighting termination should be free of hazards or decision points. Lighting should not be terminated before changes in background lighting, or roadway geometry, or at the location of traffic control devices.

F. UNDERPASSES

One of the criteria to be followed to determine requirements for underpass lighting is the relative level between illumination on the roadway inside and outside of the underpass. The height, width, and length of the underpass determines the amount of light penetration from the exterior.

F.1. Daytime Lighting

A gradual decrease in the illumination level from day time level on the roadway to the underpass should be provided. Supplemental day time lighting is normally not needed in underpasses less than 100 feet in length.

F.2. Night Lighting

The night time illumination level in the underpass should be maintained near the night time level of the approach roadway. Due to relatively low luminaire mounting heights, care should be exercised to avoid glare.

G. MAINTENANCE

A program of regular preventive maintenance should be established to ensure levels of illumination do not go below required values. The program should be coordinated with lighting design to determine the maintenance period. Factors for consideration include a decrease in lamp output, luminaire components becoming dirty, and the physical deterioration of the reflector or refractor. The maintenance of roadway lighting should be incorporated in the overall maintenance program specified in CHAPTER 10 - MAINTENANCE.

H. LIGHT POLES

Light poles should not be placed in the sidewalk when adequate right-of-way is available beyond the sidewalk.

Light poles should not be placed so as to provide a hazard to out of control vehicles. Light poles are generally not of a frangible or breakaway design and should be placed outside of the roadway recovery area. They should be as far removed from the travel lane as possible or behind adequate guardrail or other barriers. Light poles should be placed on

the inside of the curves when feasible. Foundations or poles and rigid auxiliary lighting components that are not behind suitable barriers should be constructed flush with or below the ground level. Breakaway or frangible poles should not be used where there is a high probability that a falling pole may strike a pedestrian or fall on a building or the roadway and create a greater hazard.

The use of high mast lighting should be considered, particularly for lighting interchanges and other large plaza areas. This use tends to produce a more uniform illumination level, reduces glare, and allows placement of the poles further from the roadway. Additional emphasis lighting should be considered to illuminate specific and desired pedestrian crossings.

The placement of light poles should not interfere with the driver's sight distance nor the view of signs, signals, or other traffic control devices. Further criteria regarding the placement of roadside structures, including light poles, is specified in CHAPTER 4 - ROADSIDE DESIGN.

CHAPTER 7

RAIL HIGHWAY GRADE CROSSINGS

A. INTRODUCTION

The basic design for grade crossings should be similar to that given for highway intersections in CHAPTER 3 - GEOMETRIC DESIGN. Rail-highway grade crossings should be limited in number and should, where feasible, be accomplished by grade separations. Where at-grade crossings are necessary, adequate traffic control devices and proper crossing design are required to limit the probability of crashes.

B. OBJECTIVE AND PRIORITIES

The primary objective in the design, construction, maintenance, and reconstruction of rail-highway crossings is to provide for continuous flow of traffic in a safe and efficient manner. The achievement of this objective may be realized by utilizing the following techniques in the listed sequence of priority.

B.1. Conflict Elimination

The elimination of at grade rail-highway conflicts is the most desirable procedure for promoting safe and efficient traffic operations. This may be accomplished by the closing of a crossing or by utilizing a grade separation structure.

B.2. Hazard Reduction

The design of new at-grade crossings should consider the objective of hazard reduction. In addition, an effective program of reconstruction should be directed towards reducing crash potential at existing crossings.

The regulation of intersections between railroads and all public streets and highways in Florida is vested in the FDOT (Rule 14-46). This rule contains minimum requirements for all new grade crossings.

The FDOT Rail office has other documents available that contain additional guidance for the design, reconstruction, and upgrading of existing highway railroad

grade crossings, and may be contacted for further information.

C. DESIGN OF RAIL-HIGHWAY GRADE CROSSINGS

The primary requirement for the geometric design of a grade crossing is that it provide adequate sight distance for the motor vehicle operator to make an appropriate decision as to stop or proceed at the crossing.

C.1. Sight Distance

The minimum sight distance requirements for streets and highways at rail-highway grade crossings are similar to those required for highway intersections (CHAPTER 3 - GEOMETRIC DESIGN).

C.1.a Stopping Sight Distance

The approach roadways at all rail-highway grade crossings should consider stopping sight distance no less than the values given in Table 3-14 or Figure 3-7 for the approach to stop signs. This distance shall be measured to a stopping point prior to gates or stop bars at the crossing, but not less than 15 feet from the nearest track. All traffic control devices shall be visible from the driver eye height of 3.50 feet.

C.1.b. Sight Triangle

At grade crossings without train activated signal devices, a sight triangle should be provided.

The provision of the capability for defensive driving is an important aspect of the design of rail-highway grade crossings. An early view of an approaching train is necessary to allow the driver time to decide to stop or to proceed through the crossing.

The size of this sight triangle, which is shown in Figure 7-1, is dependent upon the train speed limit, the highway design speed, and the highway approach grade. The minimum distance along the highway (d_H), includes the requirements for stopping sight distance, the offset distance (D) from the edge of track to the stopped position (15 feet), and the eye offset (d_e) from the front of vehicles (10 feet); (Figure 7-1, Case 1). The required distance (d_T) along the track, given in Table 7-1, is necessary to allow a vehicle to

stop or proceed across the track safely. Where the roadway is on a grade the lateral sight distance (d_T) along the track should be increased as noted (Table 7-1). This lateral sight distance is desirable at all crossings. In other than flat terrain it may be necessary to rely on speed control signs and devices and to predicate sight distance on a reduced speed of operation. This reduced speed should never be less than 15 mph and preferably 20 mph.

C.1.c. Crossing Maneuvers

The sight distance required for a vehicle to cross a railroad from a stop is essentially the same as that required to cross a highway intersection as given in CHAPTER 3 - GEOMETRIC DESIGN.

An adequate clear distance along the track in both directions should be provided at all crossings. This distance, when used, shall be no less than the value obtained from Figure 7-1 and Table 7-1 (Case II). Due to the greater stopping distance required for trains, this distance should be increased wherever possible.

The crossing distance to be used shall include the total width of the tracks, the length of the vehicle, and an initial vehicle offset. This offset shall be at least 10 feet back from any gates or flashing lights, but not less than 15 feet from the nearest track. The train speed used shall be equal to or greater than the established train speed limit.

The setback for determining the required clear area for sight distance (similar to that shown in Figure 3-11) should be at least 10 feet more than the vehicle offset. Care should be exercised to ensure signal supports and other structures at the crossing do not block the view of drivers preparing to cross the tracks.

C.2 Approach Alignment

The alignment of the approach roadways is a critical factor in developing a safe grade crossing. The horizontal and vertical alignment, and particularly any combination thereof, should be as gentle as possible.

C.2.a. Horizontal Alignment

The intersection of a highway and railroad should be made as near to the

right angle (90 degrees) as possible. Intersection angles less than 70 degrees should be avoided. The highway approach should, if feasible, be on a tangent, because the use of a horizontal curve tends to distract the driver from a careful observation of the crossing. The use of superelevation at a crossing is normally not possible, since this would prevent the proper grade intersection with the railroad.

C.2.b. Vertical Alignment

The vertical alignment of the roadway on a crossing is an important factor in safe vehicle operation. The intersection of the tracks and the roadway should constitute an even plane. All tracks should, preferably, be at the same elevation, thus allowing a smooth roadway through the crossing. Where the railroad is on a curve with superelevation, the vertical alignment of the roadway shall coincide with the grade established by the tracks.

Vertical curvature on the crossing should be avoided. This is necessary to limit vertical motion of the vehicle.

The vertical alignment of the approach roadway should be adjusted when rail elevations are raised to prevent abrupt changes in grade and entrapment of low clearance vehicles. See Section 316.170, Florida Statutes, for road clearance requirements.

The roadway approach to crossing should also coincide with the grade established by the tracks. This profile grade, preferably zero, should be extended a reasonable distance (at least two times the design speed in feet) on each side of the crossing. Where vertical curves are required to approach this section, they should be as gentle as possible. The length of these vertical curves shall be of sufficient length to provide the required sight distance.

C.3 Highway Cross Section

Preserving the continuity of the highway cross section through a grade crossing is important to prevent distractions and to avoid hazards at an already dangerous location.

C.3.a. Pavement

The full width of all travel lanes shall be continued through grade crossings.

The crown of the pavement shall be removed gradually to meet the grade of the tracks. This pavement cross slope shall be removed in conformance with the requirements for superelevation runoff. The lateral and longitudinal pavement slopes should normally be designed to direct drainage away from the tracks.

C.3.b. Shoulders

All shoulders shall be carried through rail-highway grade crossings without interruption.

The use of full-width paved shoulders is required at all new crossings to maintain a stable surface for emergency maneuvers. The shoulders should be paved a minimum distance of 50 feet on each side of the crossing, measured from the outside rail. It is desirable to pave 100 feet on either side to permit bicycles to exit the vehicle lane, slow for their crossing, then make an adequate search before selecting a gap for a return to the travel lane.

C.3.c. Medians

The full median width on divided highways should be continued through the crossing. The median should be contoured to provide a smooth transition on the tracks.

The use of signs and roadside delineation is recommended to discourage use of the median to cross the tracks. Signals should be installed in the median only when gate arms of 38 feet will not adequately span the approach roadway.

C.3.d Roadside Clear Zone

Although it is often not practical to maintain the full width of the roadside clear zone, the maximum clear area feasible should be provided. This clear zone shall conform to the requirements for slope and change in grade for roadside clear zones.

C.3.e. Auxiliary Lanes

Auxiliary lanes are permitted but not encouraged at signalized grade crossings that have a large volume of bus or truck traffic required to stop at all times. These additional lanes should be restricted for the use of these

stopping vehicles. The approaches to these auxiliary lanes shall be designed as storage for deceleration lanes. The exits shall be designed as acceleration lanes.

C.4. Roadway Design

The general requirements for roadside design given in CHAPTER 3 - GEOMETRIC DESIGN and CHAPTER 4 - ROADSIDE DESIGN, should be followed at grade crossings. Supports for traffic control devices may be required within the roadside recovery area. Due to the structural requirements and the necessity for continuous operation, the use of a breakaway design is not recommended. The use of a guardrail or other longitudinal barrier is also not recommended, because an out of control vehicle would tend to be directed into the crossing.

In order to reduce the hazard to errant vehicles, all support structures should be placed as far from the roadway as is practicable.

C.5. Access Control

The general criteria for access control (CHAPTER 3 - GEOMETRIC DESIGN) for streets and highways should be maintained in the vicinity of rail-highway grade crossings. Private driveways should not be permitted within 150 feet, nor intersections within 300 feet, of any grade crossing. Index No. 17882, Roadway and Traffic Standards, should also be considered.

C.6. Parking

When feasible, no parking shall be permitted within the required clear area for the sight distance visibility triangle.

C.7. Traffic Control Devices

The proper use of adequate advance warning and traffic control devices is essential for all grade crossings. Advance warning should include pavement markings and two or more signs on each approach. Each new crossing should be equipped with train-activated flashing signals. Gates, when used, should ideally extend across all lanes, but shall at least block one-half of the inside travel lane. Traffic control devices shall be installed in agreement with the MUTCD for Streets and Highways. It is desirable to include crossing arms across adjacent pedestrian or trail facilities.

C.8. Rail-Highway Grade Crossing Surface

Each crossing surface should be compatible with highway user requirements and railroad operations at the site. When installing a new rail-highway crossing or reworking an existing at-grade crossing, welded rail should be placed the entire width from shoulder point to shoulder point. Surfaces should be selected to be as maintenance free as possible.

C.9. Roadway Lighting

The use of roadway lighting at grade crossings should be considered to provide additional awareness to the driver. Illumination of the tracks can also be a beneficial safety aid.

C.10. Crossing Configuration

A recommended layout for a simple grade crossing is shown in Figure 7-2. Although the design of each grade crossing must be "tailored" to fit the existing situation, the principles given in this section should be followed in the design of all crossings. Index No 17882, Roadway and Traffic Design Standards, should also be considered.

D. MAINTENANCE AND RECONSTRUCTION

The inspection and maintenance of all features of rail-highway grade crossings shall be an integral part of each highway agency's and railroad company's regular maintenance program (CHAPTER 10 - MAINTENANCE). Items that should be given a high priority in this program include: pavement stability and skid resistance, clear sight distance, and all traffic control and protective devices.

The improvement of all substandard or hazardous conditions at existing grade crossings is extremely important and should be incorporated into the regular highway reconstruction program. The objective of this reconstruction program should be to upgrade each crossing to meet these standards. The priorities for reconstruction should be based upon the guidelines set forth by the FDOT.

TABLE 7 - 1
SIGHT DISTANCE AT RAILROAD GRADE CROSSINGS

DESIGN SIGHT DISTANCES FOR COMBINATIONS OF TRAIN AND HIGHWAY VEHICLE SPEEDS CONDITIONS: SINGLE TRACK 90° CROSSING DESIGN VEHICLE WB-60 (l=65' d _v =10') FLAT HIGHWAY GRADES NO TRAIN ACTIVATED WARNING DEVICES TRACK WIDTH (W) = 5' VEHICLE STOP POSITION (D) = 15'								
TRAIN SPEED MPH	CASE II VEHICLE DEPARTUR E FROM STOP	CASE I MOVING VEHICLE						
	VEHICLE SPEED MPH							
	0	10	20	30	40	50	60	70
	d _r (ft.) SIGHT DISTANCE ALONG RAILROAD TRACK							
10	240	145	103	99	103	112	122	134
20	480	290	207	197	207	224	245	269
30	719	435	310	296	310	337	367	403
40	959	580	413	394	413	449	489	537
50	1,199	725	517	493	517	561	611	671
60	1,439	870	620	591	620	673	734	806
70	1,679	1,015	723	690	723	786	856	940
80	1,918	1,160	827	789	827	898	978	1,074
90	2,158	1,305	930	887	930	1,010	1,101	1,209
d _h (ft.) SIGHT DISTANCE ALONG HIGHWAY								
	95	150	225	350	500	675	875	

Sight distances are required in all quadrants of the crossing.

Corrections must be made for conditions other than shown in the table, such as, multiple rails, skew, ascending and descending grades, and curvature of highways and rails. For condition adjustments and additional information refer to Railroad Guide Crossing under CHAPTER 9 - "A POLICY ON GEOMETRIC DESIGN OF HIGHWAYS AND STREETS", AASHTO 1990.

FIGURE 7 - 1
VISIBILITY TRIANGLE AT RAILROAD CROSSINGS

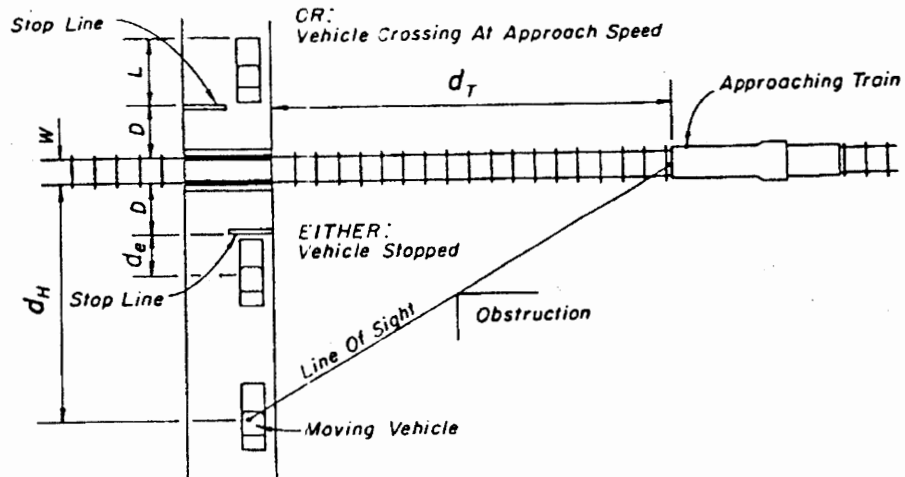

CASE I
APPROACHING VEHICLE TO SAFELY CROSS OR STOP AT RAILROAD CROSSING

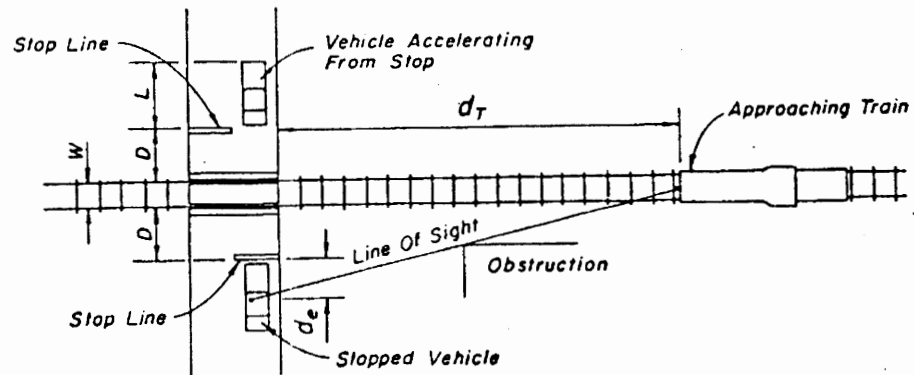

CASE II
VEHICLE DEPARTING FROM STOPPED POSITION TO SAFELY CROSS RAILROAD TRACK

For d_H and d_T values and crossing conditions see Table VII-1.

**FIGURE 7-2
 GRADE CROSSING CONFIGURATION**

RURAL

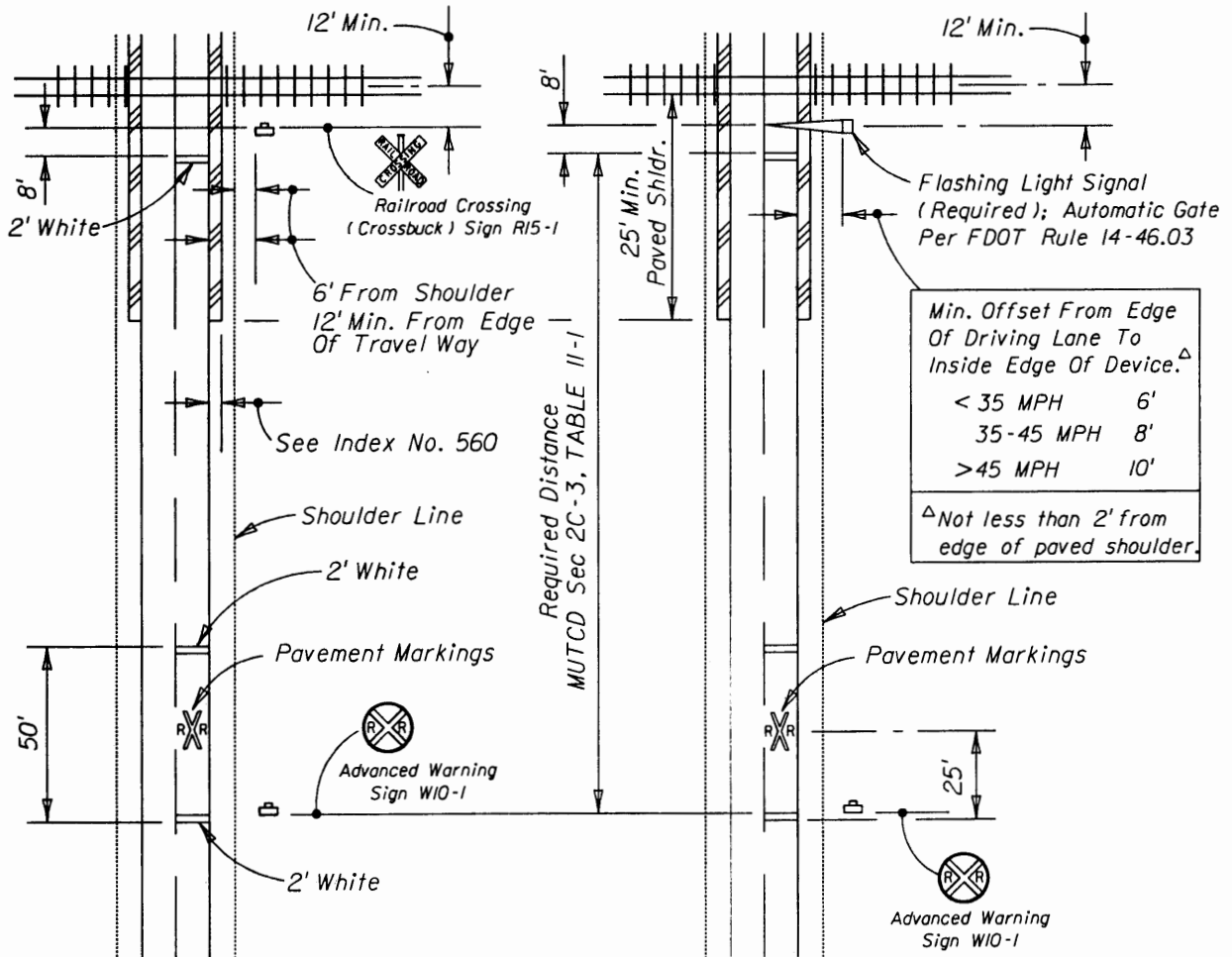

For Additional Information See The Florida Roadway and
 Traffic Design Standards, Index No. 17832.

PASSIVE CROSSING

ACTIVE CROSSING

CHAPTER 8

PEDESTRIAN TRAFFIC

A. INTRODUCTION

All new highways, except limited access highways, should be designed and constructed under the assumption they will be used by pedestrians. Provisions for pedestrian traffic should be incorporated into the original highway design.

In addition to providing pedestrian facilities on new projects, each highway agency responsible for maintaining or operating streets and urban highways should establish and maintain a program of pedestrian facilities implementation, maintenance and safety for the urban highway network.

For information concerning the design of shared use paths, refer to Chapter 9-BICYCLE FACILITIES.

B. MINIMIZING CONFLICTS

The planning and design of new streets and urban highways shall include provisions that minimize vehicle-pedestrian conflicts. Features requiring special attention include pedestrian crossings, center raised medians, pathways parallel to the roadway, bus stops and shelters, and other pedestrian activity adjacent to the street or highway.

In some situations it may be possible to eliminate a vehicle-pedestrian conflict. The elimination of vehicle-pedestrian conflict points requires close coordination with the planning of pedestrian pathways and activity outside of the highway right of way. Care should be exercised to ensure the elimination of a given conflict point does not merely transfer the problem to a different location. A reduction in the number of conflict points allows for economical and effective control and protection at the remaining points of conflict, thus providing an efficient method of pedestrian hazard reduction. Procedures for the elimination of vehicle-pedestrian conflicts are given in the subsequent material.

Any effort to minimize or eliminate conflict points must consider the mobility needs of the pedestrian: desired travel path should not be severed and walking distances should not be

significantly increased. Some conflict areas will have to be redesigned rather than eliminated or relocated.

B.1 General Needs

The minimizing of vehicle-pedestrian conflicts is accomplished by providing adequate horizontal, physical, or vertical (primarily for crossings) separation between the roadway and the pedestrian pathways.

B.2 Independent Systems

One ideal method for eliminating vehicle-pedestrian conflicts is to provide essentially independent systems for vehicular and pedestrian traffic. This requires adequate land use allocation and restriction (CHAPTER 2 - LAND DEVELOPMENT) and the proper layout and design of pedestrian pathways and the surface transportation network.

Where independent systems are provided, intersections between the two modes (i.e., parking areas) are still required. Due to the small number of these intersections or conflict points, they can be economically developed for safe and efficient operation.

B.3 Horizontal Separation

The development of independent systems for pedestrian and vehicular traffic is the preferred method for providing adequate horizontal separation.

B.3.a. General Criteria

Pedestrian pathways should be placed at least as far from the rural roadway, particularly those with flush shoulders, as stipulated by the following criteria, which are given in a sequence of desirability:

- Outside of the highway right of way in a separately dedicated corridor
- At or near the right of way line (ideally, 3 feet width should be provided behind the sidewalk for above ground utilities)
- Outside of the designed roadside clear zone

- Outside of the minimum required roadside clear zone (CHAPTER 3 - GEOMETRIC DESIGN)
- As far from the edge of the driving lane as possible
- Sidewalks which are set back from the roadway will need to be brought closer to the roadway at intersections. This will allow for proper placement of crosswalks and stop bars.

C. BARRIER SEPARATION

Barriers may be used to assist in the separation of vehicular and pedestrian traffic.

C.1 Longitudinal Barriers

Longitudinal barriers such as guardrails, rigid barriers and bridge railings are designed primarily to redirect errant vehicles away from roadside hazards. These barriers can also be used to provide valuable protection of pedestrian pathways from out of control vehicles.

Where adequate horizontal separation is not feasible, or where there is a significant hazard from out of control vehicles, longitudinal barriers may be utilized.

C.2 Fencing or Landscaping

The elimination of many potential vehicle-pedestrian conflicts may be accomplished by fencing or landscaping to prevent pedestrian access to the roadway and to aid in channeling pedestrian traffic to the proper crossing points. Fencing or landscaping shall not be considered as a substitute for longitudinal barriers, but may be used in conjunction with these redirection devices.

Fencing or landscaping may be utilized to prevent access to streets and highways at the locations described in B.1 General Needs. Fencing at the right of way line and placement of pedestrian (and bicycle) pathways in separate corridors outside of this line is a necessary procedure on limited access facilities.

D VERTICAL SEPARATION

Vertical separation may be selectively utilized to effect the crossing of large pedestrian volumes and high speed highways particularly where the traffic volume on the roadway is at or near capacity. This method of conflict elimination is often justified at major pedestrian generators such as schools, shopping centers, sports and amusement facilities, transit centers, commercial buildings, parks and playgrounds and parking facilities.

D.1 Overpasses

The design of pedestrian bridges or overpasses should include provisions for additional vertical clearance, since the consequences of being struck by a vehicle may be quite serious. Bridges should be covered or screened to reduce the likelihood of objects being dropped or thrown onto the roadway below.

D.2. Underpasses

Pedestrian underpasses or tunnels perform the same function as overpasses. Their use is often convenient when the roadway is elevated somewhat above the surrounding terrain.

Underpasses may, however, be undesirable due to possible problems in lighting, cleaning, policing and flooding and therefore, should be adequately maintained to maximize safety. The area adjacent to overpasses and underpasses may be fenced to prevent unsafe crossings and to channel pedestrians to the vertical separation structure.

E. PROTECTION

The design of all pedestrian crossings and parallel pathways within the right of way shall be considered an integral part of the overall design of a street or urban highway.

The development of protection at any remaining crossings or conflict points must be adequate to achieve a total pedestrian transportation mode that is reasonably safe.

E.1. Crossings

Curb ramps meeting the requirements of ADA, shall be constructed at crosswalks at all intersections where curbs and sidewalks are constructed in order to give persons with disabilities safe access.

The design of pedestrian crossings should be based on the following requirements:

- Crossings should be placed at locations with ample sight distances
- At crossings, the roadway should be free from changes in alignment or cross section
- The entire length of crosswalk shall be visible to drivers at a sufficient distance to allow a stopping maneuver
- Stop bars shall be provided adjacent to all signalized crosswalks to inform drivers of the proper location to stop. The stop bar should be well separated from the crosswalk, but should not be closer than 4 feet.
- All crosswalks shall be easily identified and clearly delineated, in accordance with Manual on Uniform Traffic Control Devices (MUTCD) (Rule 14-15.010)

E.2. Controls

Signs, signals and markings should be utilized to provide the necessary information and direction for pedestrians. All directions and regulations should be clear, consistent and logical and should, as a minimum, conform to the requirements given in the MUTCD. The use of audible tactile as well as visual signals should be considered for pedestrian traffic control and regulation.

E.3. Sight Distance

The general requirements for sight distances for the driver are given in CHAPTER 3 - GEOMETRIC DESIGN.

Stopping sight distances greater than the minimum should be provided at all

pedestrian crossings. These sight distances should include a clear view of the pedestrian approach pathway for at least 15 feet from the outside travel lane. Where parallel pedestrian pathways are within the roadside recovery area, or where casual pedestrian crossings are likely, the normal required stopping sight distance should also include a clear view of the entire roadside recovery area.

Sight distances shall be based upon a driver's eye and object height as discussed in Chapter 3. Due to the small height and diameter of pedestrians (particularly children), they are generally easy to confuse with other background objects.

Parking shall be prohibited where it would interfere with the required sight distance. Particular care should be exercised to ensure ample mutual sight distances are provided at all intersections and driveways.

E.4. Lighting

Illumination of the roadway itself is not only important for the safety of vehicular traffic, but also valuable for the protection of pedestrians. Vehicle headlamps often do not provide sufficient illumination to achieve the required stopping sight distance. Since this requirement is of vital importance at any potential pedestrian crossing point, illumination of the crossing should be considered. Lighting a street or highway is also valuable in improving the pedestrian's view of an oncoming vehicle. At intersections or other locations with vehicle turning maneuvers, the vehicle headlights may not be readily visible to the pedestrian.

The general requirements for lighting on streets and highways are given in CHAPTER 6 - ROADWAY LIGHTING. Pathways adjacent to a street or highway should not be illuminated to a level more than twice that of the roadway itself.

In general, lighting should be considered as warranted when it is necessary, at night, to provide the mutual sight distance capabilities described in the preceding CHAPTER 3 - GEOMETRIC DESIGN. Locations with significant night time pedestrian traffic that should be considered for lighting of the roadway and adjacent pedestrian pathways include the following:

- Any street or highway that meets the warranting criteria given in CHAPTER 6 - ROADWAY LIGHTING
- Streets and highways with a speed limit in excess of 40mph that do not have adequate pedestrian conflict elimination

- Sections of highway with minimal separation of parallel pedestrian pathways
- Intersections, access and decision points, and areas adjacent to changes in alignment or cross sections
- Areas adjacent to pedestrian generators
- Bus stops and other mass transit transfer locations
- Parking facilities
- Entertainment districts, sports/recreation complexes, schools and other activity centers generating night travel
- Pedestrian crossings
- Any location where improvement of night time sight distance will reduce the hazard of vehicle-pedestrian conflicts.

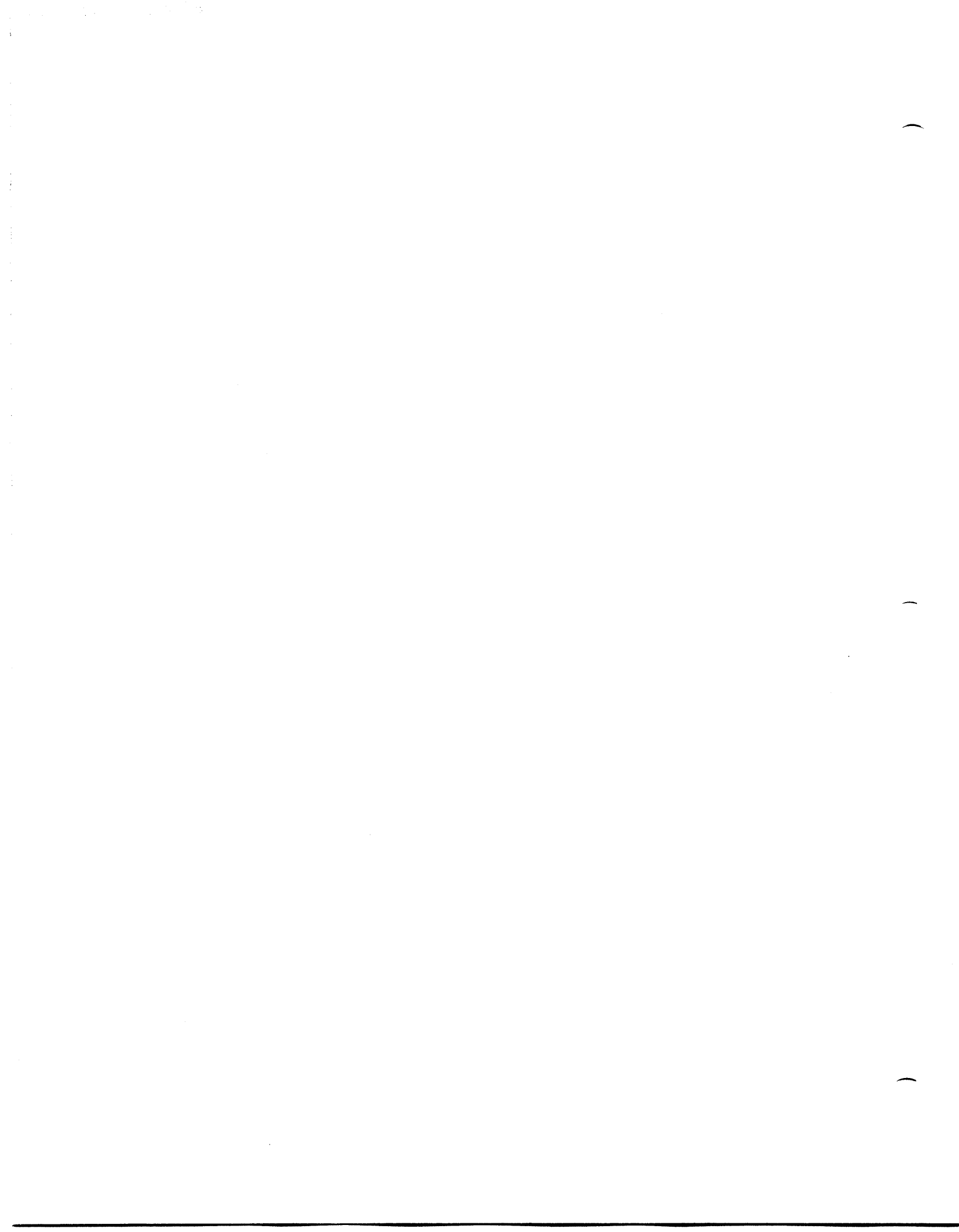

CHAPTER 9

BICYCLE FACILITIES

A. INTRODUCTION

Because bicyclists can be expected to ride on most roadways, bicycles should be considered in all phases of transportation planning, new roadway design, roadway construction and capacity improvement projects, and transit projects. All projects, particularly intersection modification, should be designed to accommodate bicyclists.

To varying extents, bicycles will be ridden on all streets and highways where they are permitted. Bicycle-safe design practices, as described in this Manual, should be followed during initial roadway design to avoid costly subsequent improvements.

B. ON-STREET FACILITIES

The provision for bicycle traffic should be incorporated in the original highway design. New highways, except limited access highways, should be designed and constructed under the assumption they will be used by bicyclists. Roadway conditions should be favorable for bicycling. This requires special care in preparing the roadway surface to accommodate 1¼ inch tires. Attention needs to be given to include safe drainage grates and railroad crossings, smooth pavements, and signals responsive to bicycles. In addition, the desirability of adding facilities, such as bicycle lanes and shoulder improvements, should be included to the fullest extent feasible. Specifically, all rural arterial and collector sections within one mile of an urbanized area should be given consideration for the construction of 4 to 5 feet paved shoulders, and all urban arterial and collector sections should be given consideration for either undesignated 4 foot lanes or marked bike lanes.

B.1. Paved Shoulders

In rural areas, or on sections without curb and gutter, adding or improving paved shoulders often can be the best way to accommodate bicyclists. Paved shoulders also benefit motor vehicle traffic.

Paved shoulders should be at least 4 feet wide to accommodate bicycle travel. The measurement of shoulder width does not include the width of any gutter pan. Paved shoulder width of 5 feet is recommended from the face of guardrail, curb, or

other roadside barrier. Additional shoulder width is desirable if motor vehicle speeds exceed 55 mph, or the percentage of trucks, buses or recreational vehicles is high.

If paved shoulders 4 feet wide cannot be provided, consider adding 3 foot shoulders. The only practical difference in the operation of a 3 foot shoulder and wider shoulders, as they relate to bicyclists, is a slight decrease in motorist-bicyclist separation distances. Other operational characteristics, such as motorist encroachment into adjacent lanes while passing and changes in the motorist position within the lane while passing are not significantly impacted.

B.2. Bike Lanes

Bicycle lanes should be considered when it is desirable to delineate available road space for preferential use by bicyclists and motorists, and to provide for more predictable movements by each. Bicycle lane markings can increase bicyclists' confidence of motorists not straying into their path of travel. Likewise, passing motorists are less likely to swerve to the left out of their lane to avoid bicyclists on the right.

Bicycle lanes should be one-way facilities and carry bike traffic in the same direction as the adjacent motor vehicle lane. In most cases, bike lanes will be through lanes and be located to the right of the right most through lane.

Two-way bike lanes on one side of the roadway are not recommended when they result in riding against the flow of motor vehicle traffic. Wrong-way riding is a major cause of bicycle crashes and violates the Rules of the Road as stated in the Uniform Vehicle Code and Chapter 316, Florida Statutes. Bicycle specific wrong-way signing may be used to discourage wrong-way travel. There may be special situations where a two-way bike lane for a short distance can eliminate the need for bicyclists to make a double crossing of a busy street. This should be considered after a careful evaluation of the risks.

On one-way streets, bike lanes should generally be placed on the right side of the street. Bike lanes on the left side are unfamiliar and unexpected for most motorists. This should only be considered when a bicycle lane on the left will substantially decrease the number of conflicts, such as those caused by heavy bus traffic or unusually heavy movements to the right, or if there are a significant number of left-turning bicyclists. Thus, left side bike lanes should only be considered after careful evaluation. Similarly, two-way bike lanes on the left side of a one-way street with

a suitable separation from the motor vehicle should only be considered after a complete engineering study of other alternatives and relative risks.

One-way bicycle lanes should be designed with the minimum width given in Figure 9 - 1. The 4 foot bike lane shown assumes the shoulder provides emergency maneuvering room.

B.3. Curb Lanes

In restricted urban conditions, where it is not possible to include bike lanes or paved shoulders or on lower volume collector streets, an outside lane wider than 12 feet can help accommodate both bicycles and motor vehicles in the same lane. In many cases, where there is a wide curb lane, motorists will not need to change lanes to pass a bicyclist.

In general, 14 feet of usable lane width is the recommended width for shared use in a wide curb lane.

C. SHARED USE PATHS

Shared use paths are facilities usually on exclusive right of way, with minimal cross flow by motor vehicles. Users are non-motorized and may include, but are not limited to, the following:

- Bicyclists
- In-line skaters
- Roller skaters
- Skateboarders
- Wheelchair users
- Pedestrians (walkers, runners, people with baby strollers, people walking dogs, etc.)

Shared use paths can serve a variety of purposes. They can provide users with a shortcut through a residential neighborhood. Shared use paths can also provide access to areas otherwise served only by limited access highways. For transportation purposes, they

should be thought of as an extension of the roadway network for non-motorized users. The inclusion of a shared use path should not be considered as an alternative to providing in-street facilities, but, rather, as a supplement.

For a discussion of shared path design beyond what is in this chapter, refer to the Florida Bicycle Facilities Planning and Design Handbook.

C.1. Separation Between Shared Use Paths and Roadways

Shared use paths should be separated from the roadway. In some cases, paths along highways for short sections are permissible, given an appropriate level of separation between facilities. Some problems with paths located immediately adjacent to the roadways are as follows:

- Unless separated, they require one direction of bicycle traffic to ride against motor vehicle traffic, contrary to normal rules of the road.
- When paths end, bicyclists going against traffic will tend to continue to travel on the wrong side of the street. Likewise, bicyclists approaching a path often travel on the wrong side of the street to get to the path. Wrong-way travel by bicyclists is a major cause of bicycle/automobile crashes and should be discouraged at every opportunity.
- At intersections, motorists entering or crossing the roadway often will not notice bicyclists coming from the right, as they are not expecting or looking for contra-flow vehicles. Motorists turning to exit the roadway may likewise fail to notice the bicyclists. Even bicyclists coming from the left (the expected direction) often go unnoticed, especially when sight distances are limited.
- When constructing a two-way path within a narrow right of way, sacrificing the shoulder on the adjacent roadway would be a detriment to both the motorist and the bicyclists and should be avoided if at all possible.
- Many bicyclists will use the roadway instead of the shared use path because they have found the roadway to be safer, less congested, more convenient, or better maintained. Bicyclists using the roadway are often subjected to harassment by motorists who feel that, in all cases, bicyclists should be on the path instead.

- Although the shared use path should be given the same priority through intersections as the parallel highway, motorists falsely expect bicyclists to stop or yield at all cross streets and driveways. Efforts to require or encourage bicyclists to yield or stop at each cross street and driveway are inappropriate and frequently ignored by bicyclists.
- Stopped cross street motor vehicle traffic or vehicles exiting side streets or driveways may block the path crossing.
- Because of the proximity of motor vehicle traffic to opposing bicycle traffic, barriers are often necessary to keep motor vehicles out of shared use paths and bicyclists out of traffic lanes. These barriers can represent an obstruction to bicyclists and motorists, can complicate maintenance of the facility, and cause other problems.

When the distance between the shared use path and the highway shoulder is less than 5 feet, a physical barrier is recommended. Where used, the barrier should be a minimum of 42 inches high, to prevent cyclists from toppling over it. A barrier between a shared use path and an adjacent highway should not impair sight distance at intersections, and should be designed to not be a hazard to errant motorists.

C.2. Width

The paved width and operating width required for a shared use path are primary design considerations. The minimum recommended width for a paved two-way path is 10 feet. In many cases, it is desirable to increase the minimum width to 12 feet. The width should be increased if there is expected substantial use by bicyclists, probable shared use with joggers and in-line skaters, steep grades, and locations where bicyclists are likely to ride two abreast.

In a few cases, it may be acceptable to decrease the trail width to 8 feet. This width should only be used where the following conditions prevail:

- Bicycle traffic is expected to be low, even on peak days or during peak hours
- Pedestrian use of the facility is not expected to be more than occasional
- There will be good horizontal and vertical alignment, providing safe and frequent passing opportunities

- During normal maintenance activities, the path will not be subjected to maintenance vehicle damage causing pavement edge damage

For further discussion of shared use path design, refer to the Florida Bicycle Facilities Planning and Design Handbook.

C.3 Horizontal Clearance

A minimum 2 foot wide graded area with a maximum 1:6 slope should be maintained adjacent to both sides of the path; however, 3 feet or more is desirable to provide clearance from trees, poles, walls, fences, guardrails or other lateral obstructions. Where the path is adjacent to canals, ditches or slopes steeper than 1:3, a wider separation should be considered. A minimum 5 foot separation from the edge of the path pavement to the top of the slope is desirable. Depending on the height of embankment and condition at the bottom, a physical barrier, such as dense shrubbery, railing or chain link fence, may need to be provided.

C.4 Vertical Clearance

Vertical clearance to obstructions should be a minimum of 8 feet. However, vertical clearance may need to be greater to permit passage of maintenance and emergency vehicles. In undercrossings and tunnels, 10 feet is desirable.

C.5 Design Speed

A design speed of 20 mph should be used for shared use paths.

C.6 Structures

The minimum clear width on structures should be the same as the approach shared use path, plus the minimum 2 foot wide clear areas.

Grades on structures to be used by pedestrians shall comply with the requirements of the Florida Accessibility Code For Building Construction as given in Chapter 3.

FIGURE 9 - 1
MINIMUM WIDTHS FOR BIKE LANES

a) Curbed Street without Parking

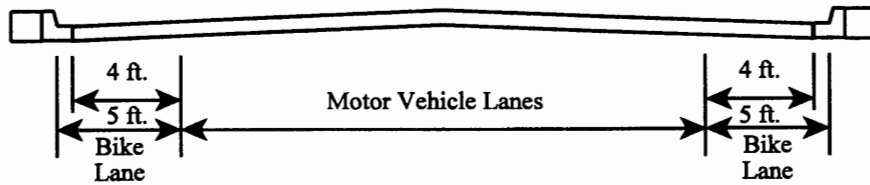

b) Curbed Street with Parking

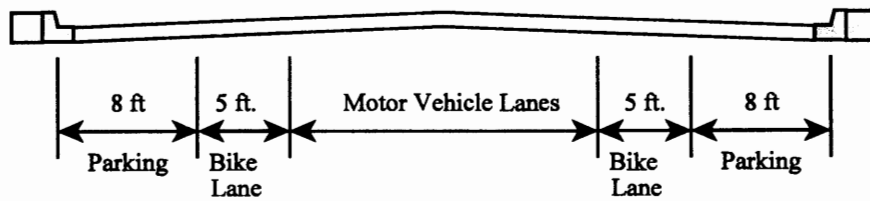

c) Roadway without Curb and Gutter

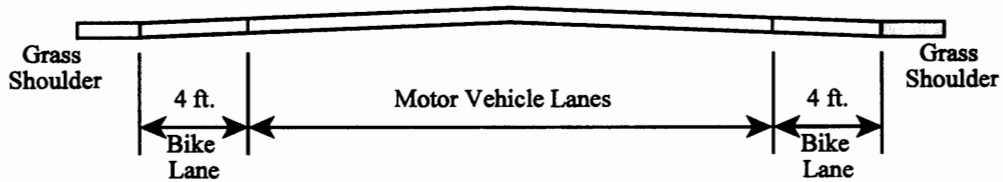

FIGURE 9 - 2
MAJOR INTERSECTION WITH SEPARATE
RIGHT TURN LANE URBAN TYPICAL SECTION (CURB AND GUTTER)

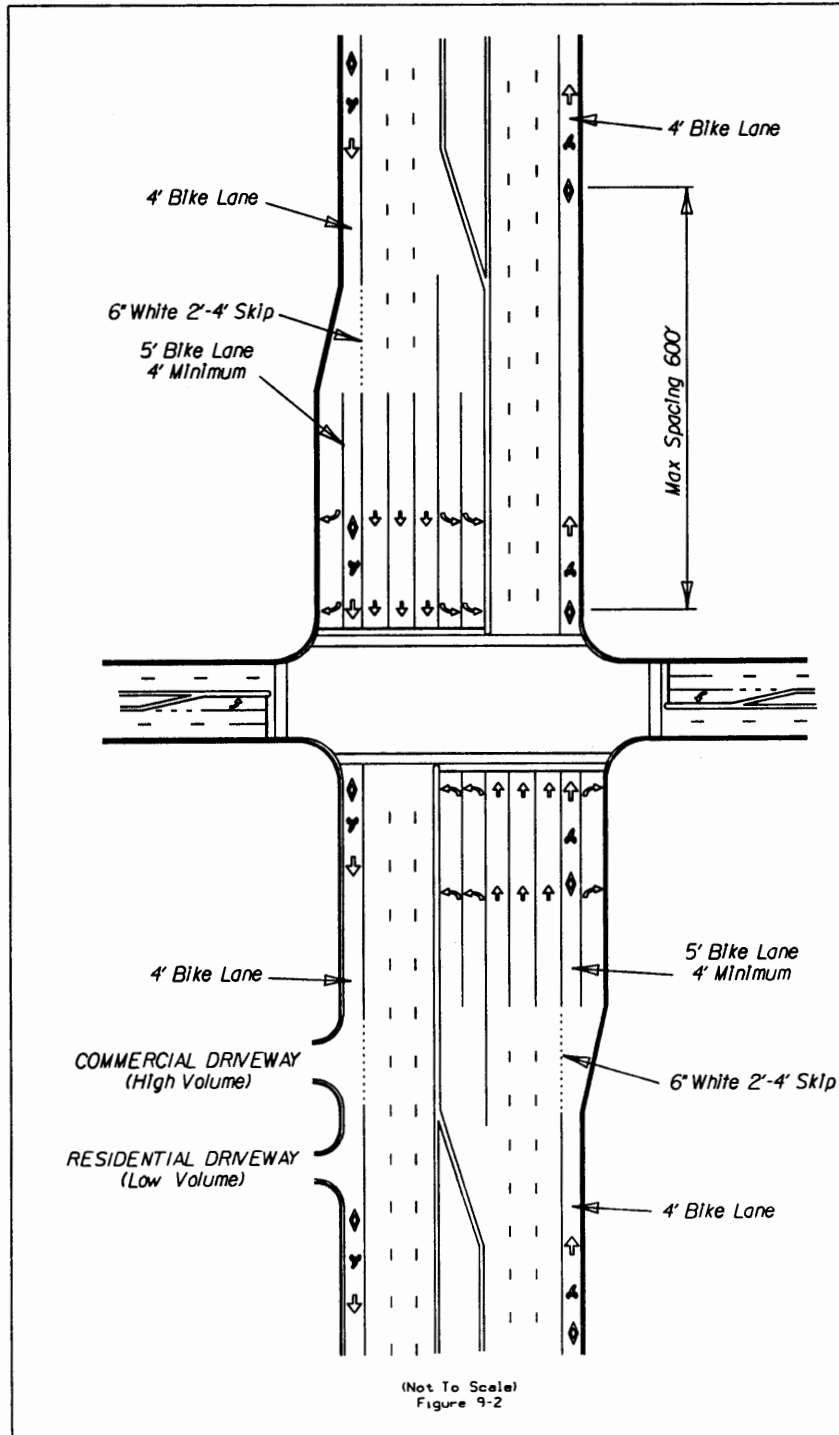

FIGURE 9 - 3
MAJOR INTERSECTION NO RIGHT TURN LANE PLUS BUSBAY
URBAN TYPICAL SECTION (CURB AND GUTTER)

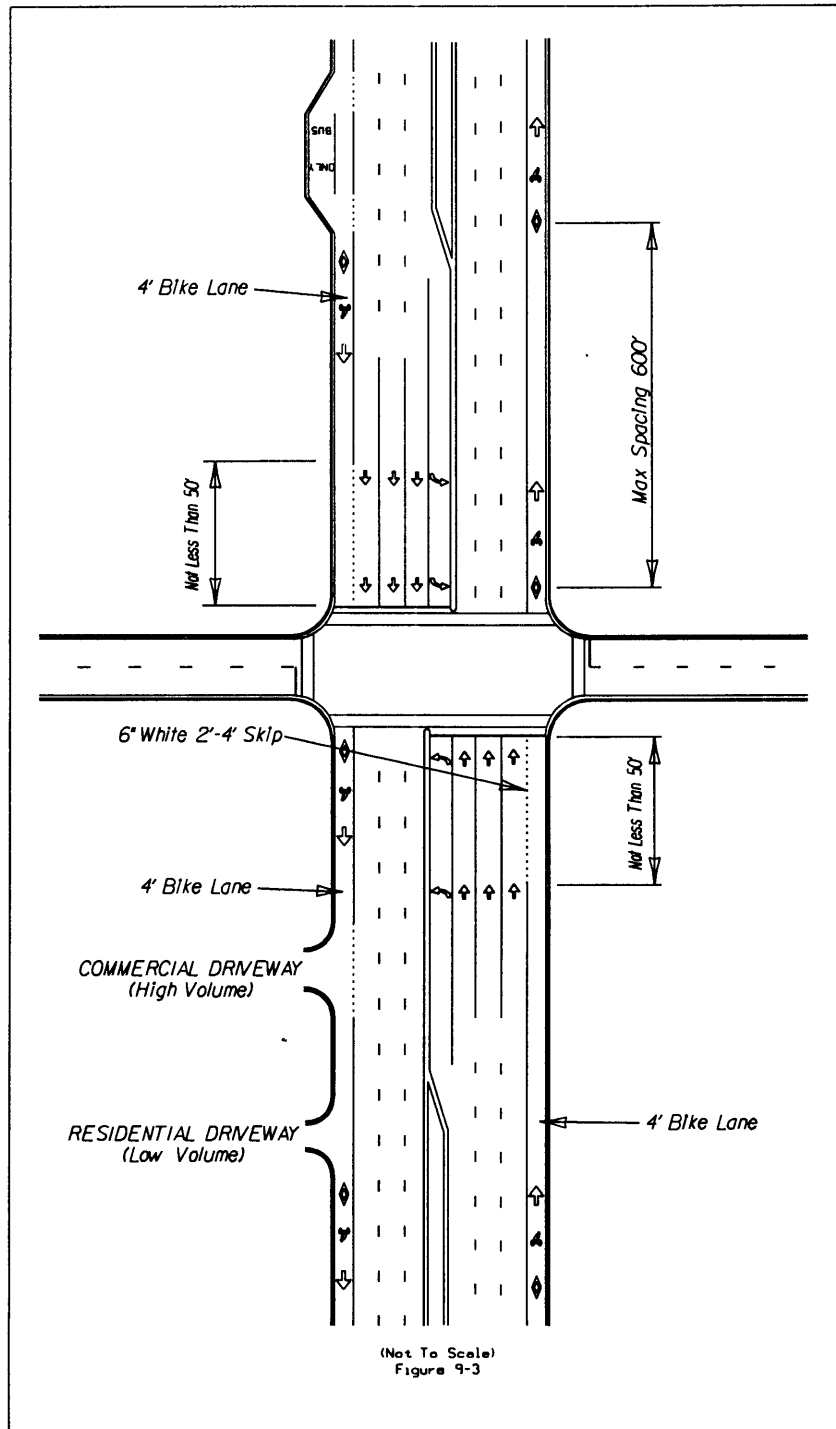

FIGURE 9 - 4
MAJOR WITH LOCAL STREET INTERSECTION NO RIGHT TURN LANE
URBAN TYPICAL SECTION (CURB AND GUTTER)

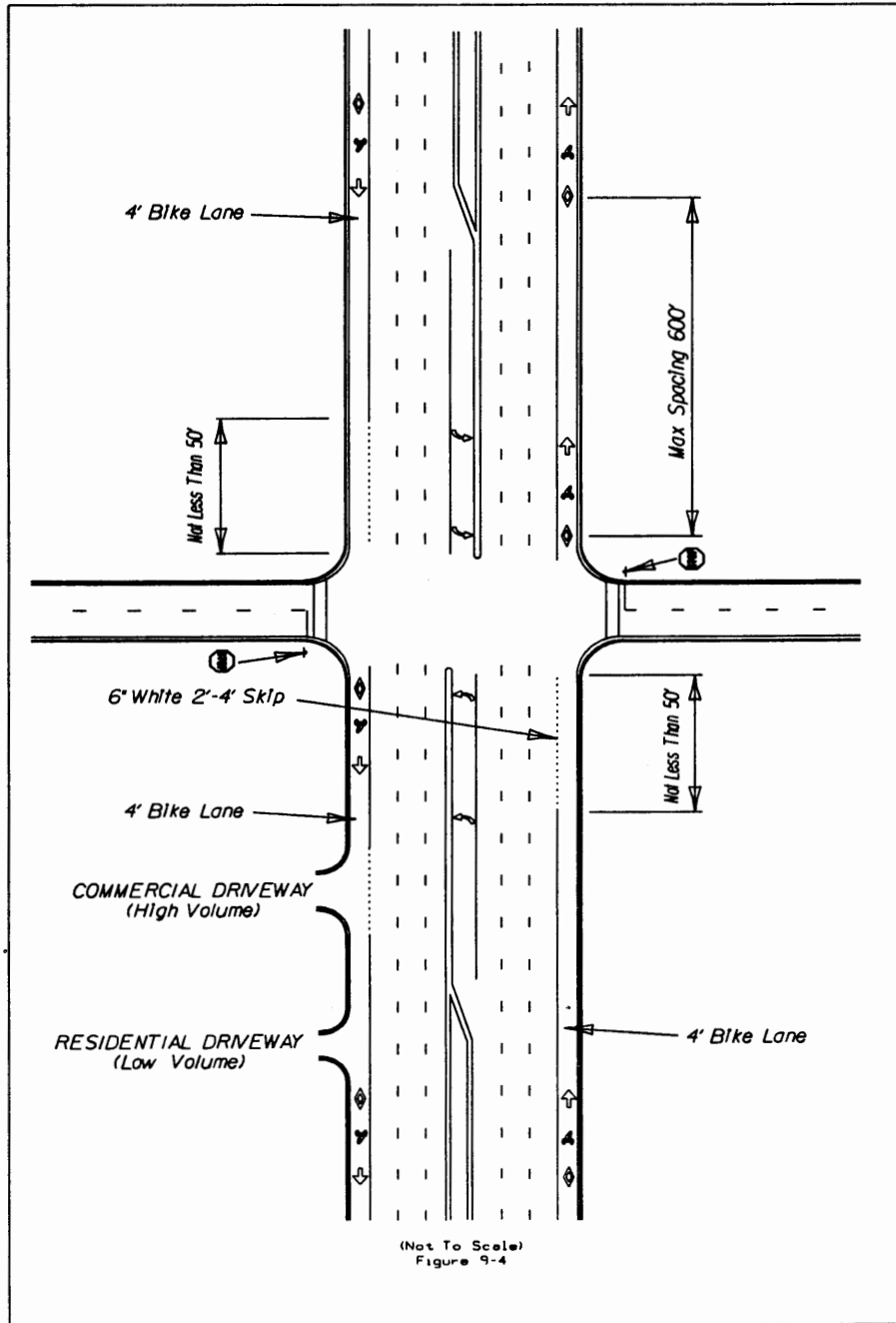

FIGURE 9 - 5
MAJOR WITH LOCAL STREET INTERSECTION NO RIGHT TURN LANE
ON STREET PARKING URBAN TYPICAL SECTION (CURB AND GUTTER)

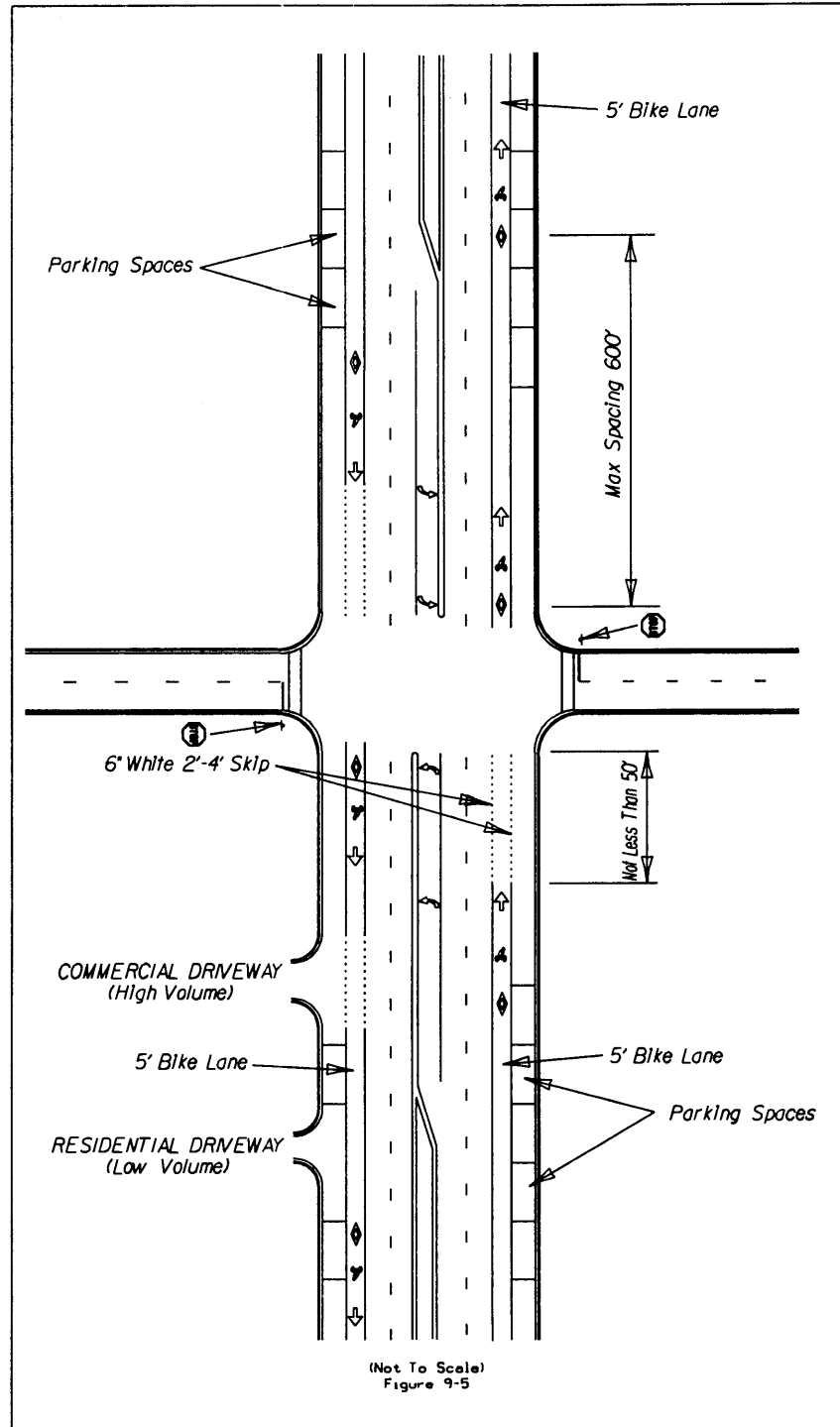

FIGURE 9 - 6
MAJOR INTERSECTION WITH DESIGNATED SHOULDER SEPARATE
RIGHT TURN LANE RURAL TYPICAL SECTION (PAVED SHOULDER)

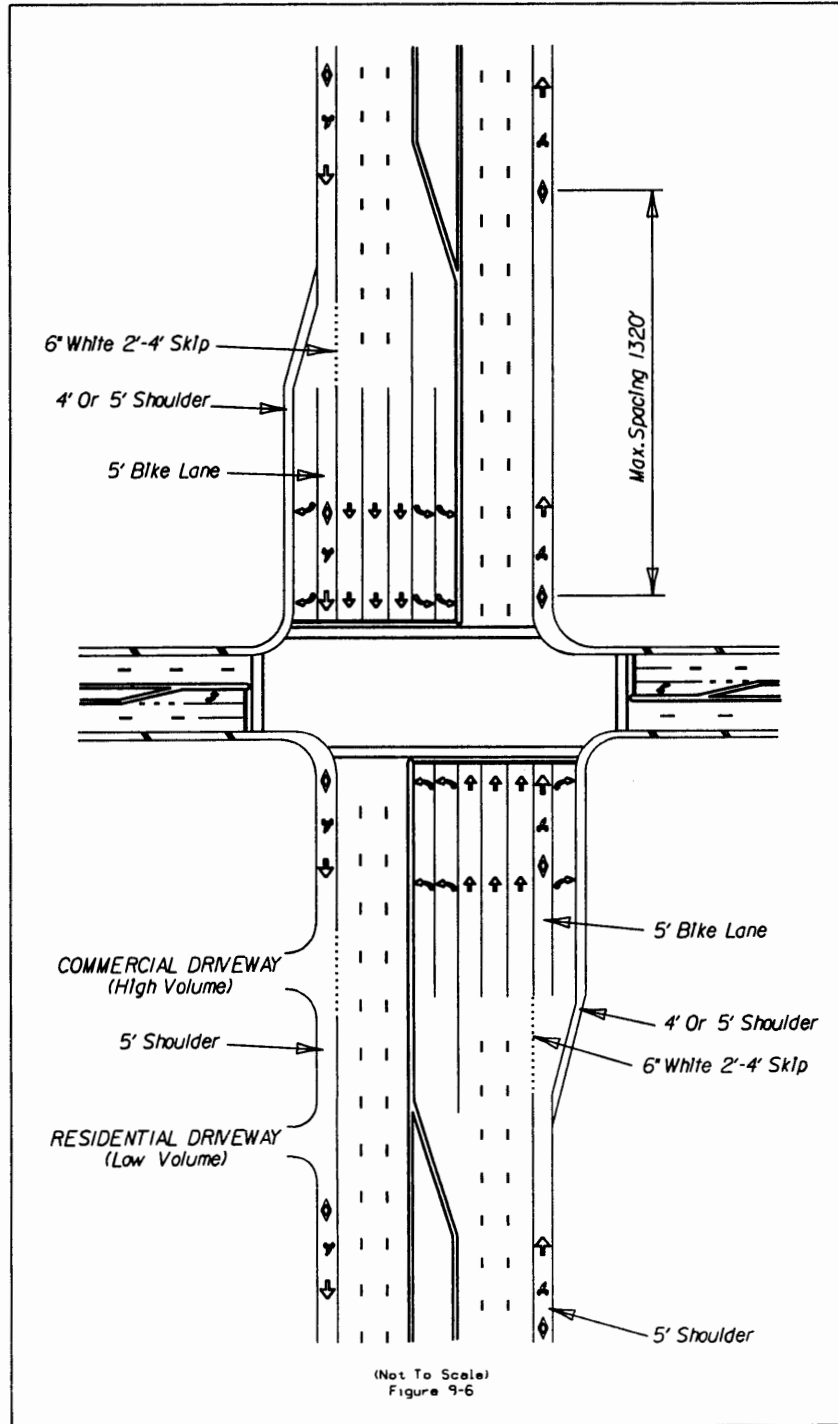

FIGURE 9 - 7
MAJOR WITH LOCAL STREET INTERSECTION DESIGNATED SHOULDER
NO RIGHT TURN LANE RURAL TYPICAL SECTION (PAVED SHOULDER)

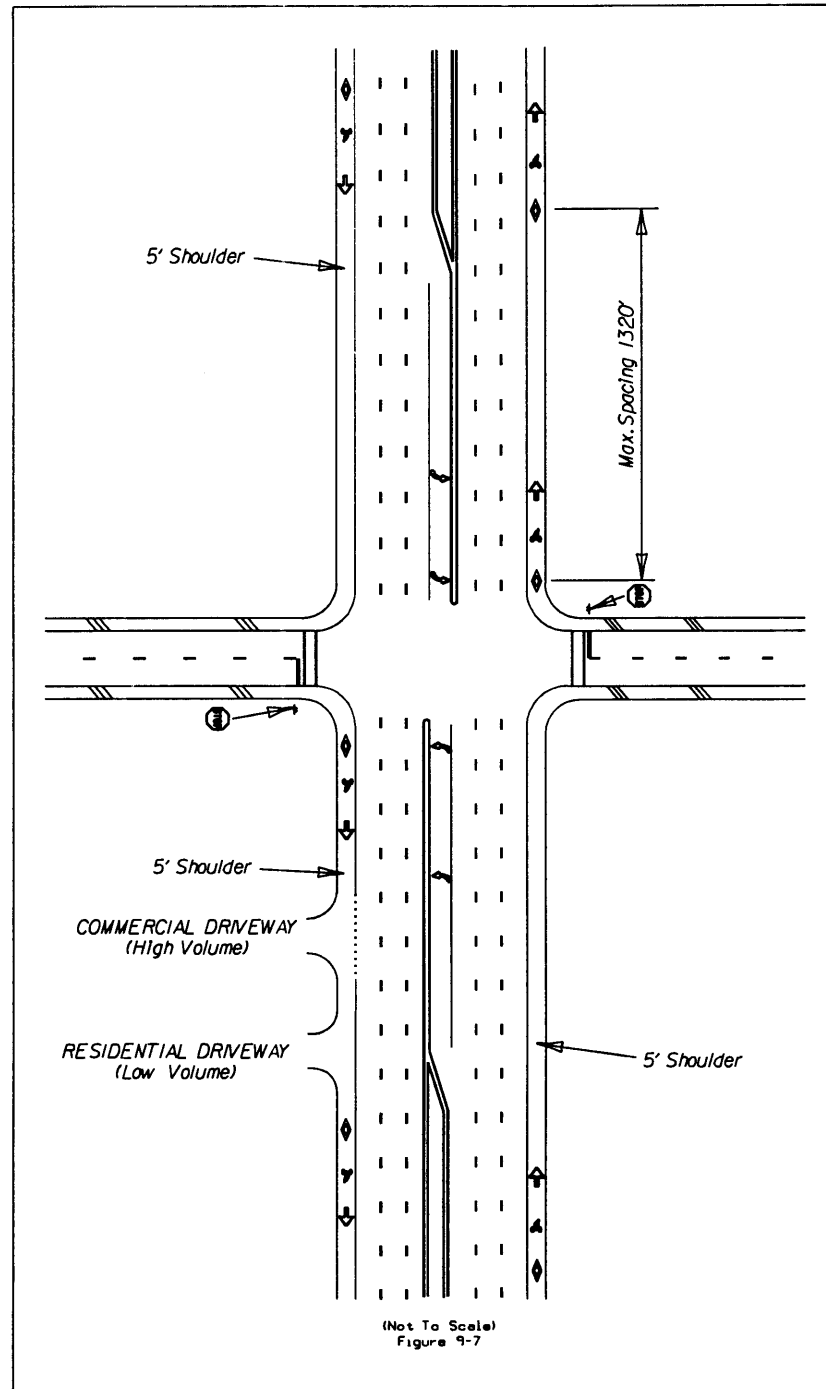

FIGURE 9 - 8
MAJOR INTERSECTION SEPARATE RIGHT TURN LANE 3' OR 4' UNDESIGNATED
BIKE LANE URBAN TYPICAL SECTION (CURB AND GUTTER)

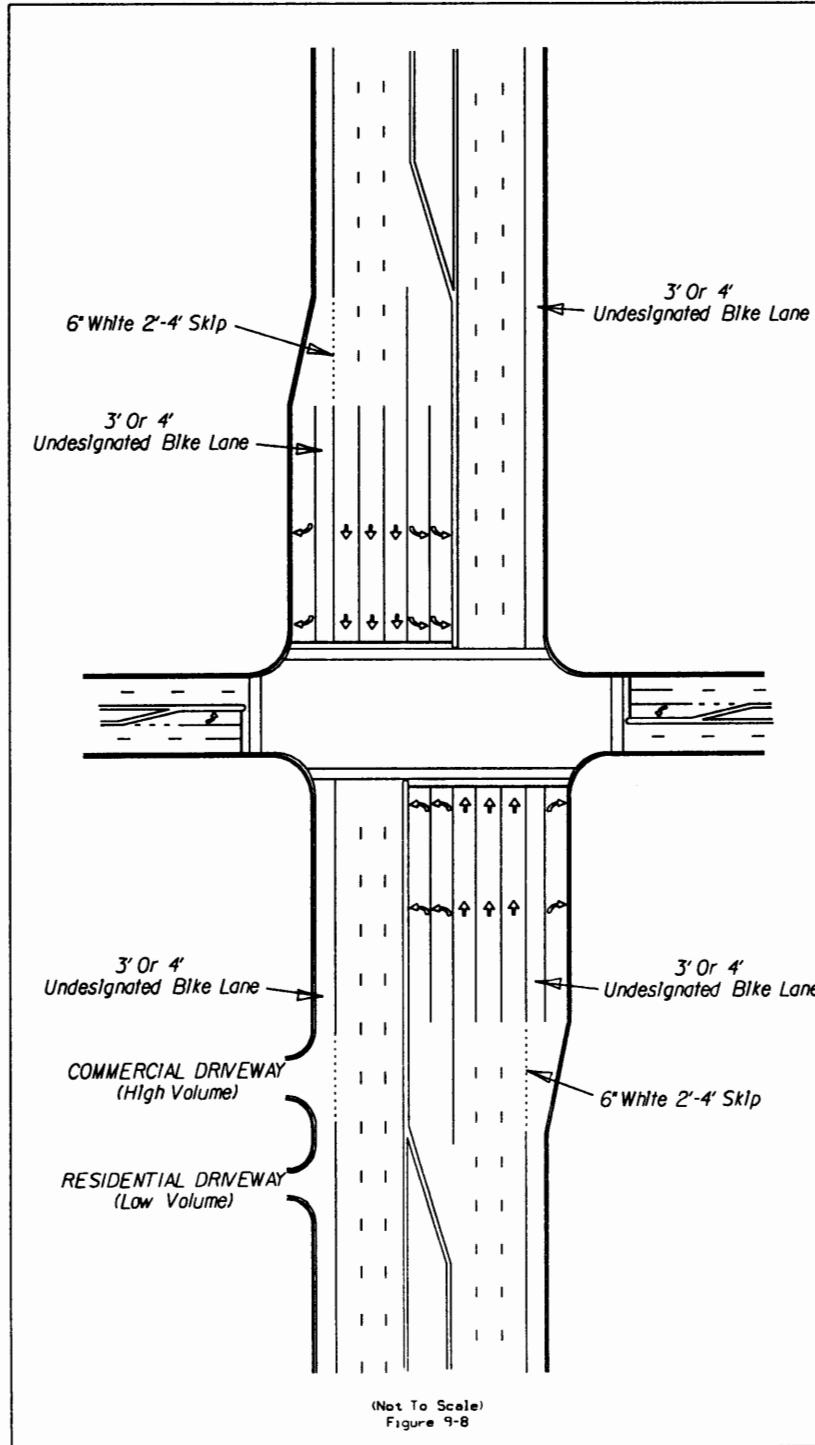

FIGURE 9 - 9
MAJOR INTERSECTION RIGHT TURN DROP LANE DESIGNATED OR
UNDESIGNATED BIKE LANE URBAN TYPICAL SECTION (CURB AND GUTTER)

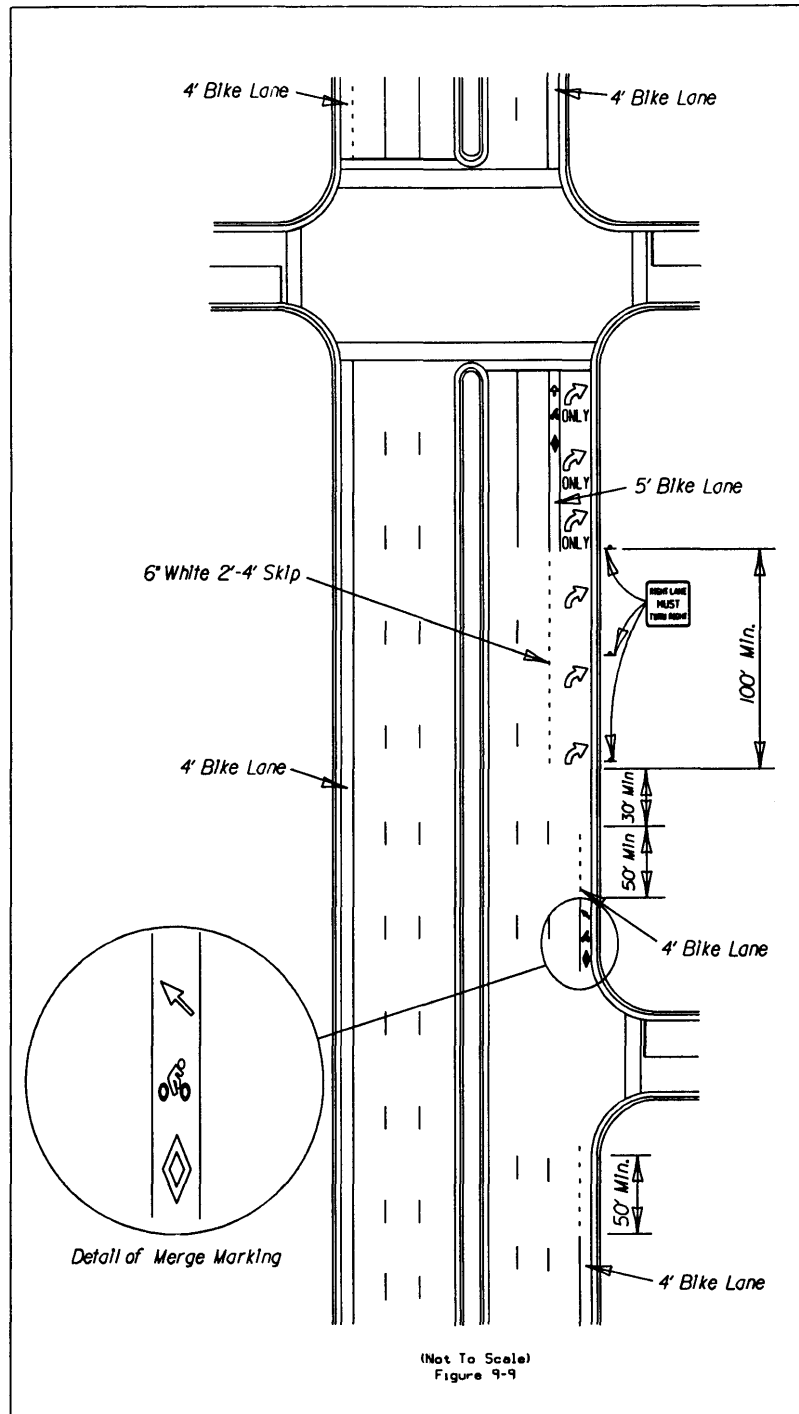
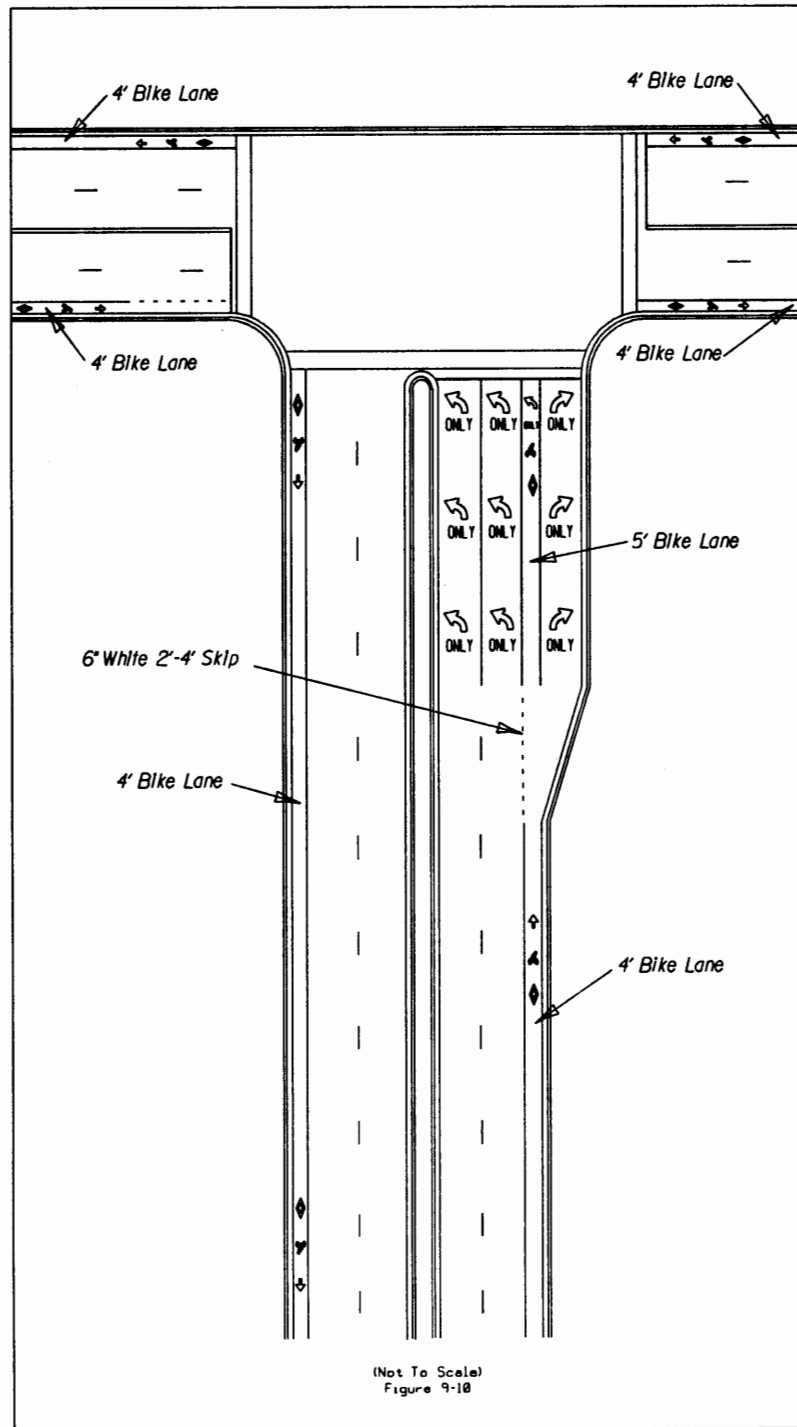
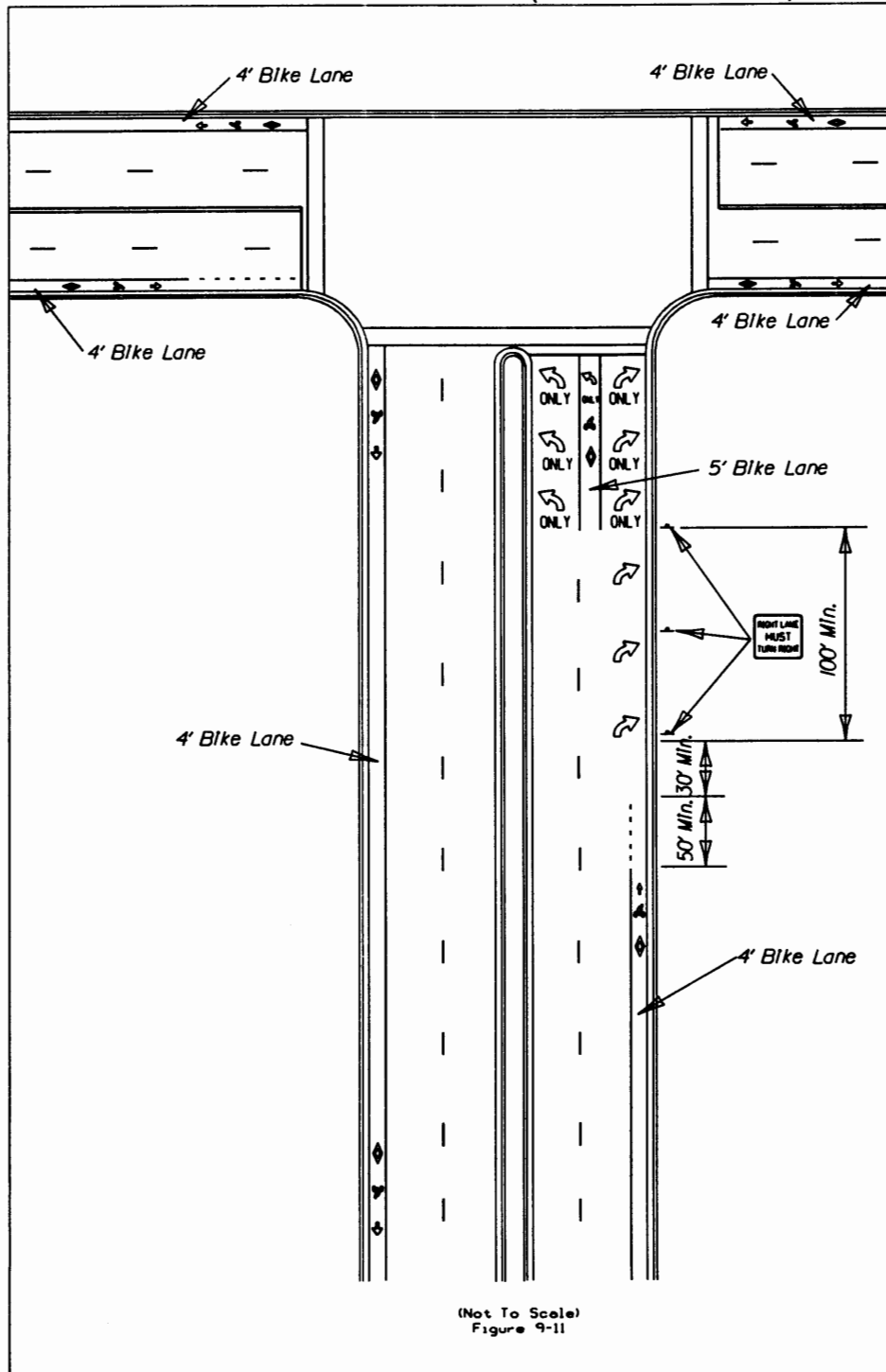

FIGURE 9 - 10
"TEE" INTERSECTION SEPARATE RIGHT TURN LANE
URBAN TYPICAL SECTION (CURB AND GUTTER)



(Not To Scale)
Figure 9-10

FIGURE 9 - 11
"TEE" INTERSECTION RIGHT TURN DROP LANE
URBAN TYPICAL SECTION (CURB AND GUTTER)



(Not To Scale)
Figure 9-11

FIGURE 9 - 12
DETAIL OF DESIGNATED BIKE
LANE AND BIKE SHOULDER MARKINGS

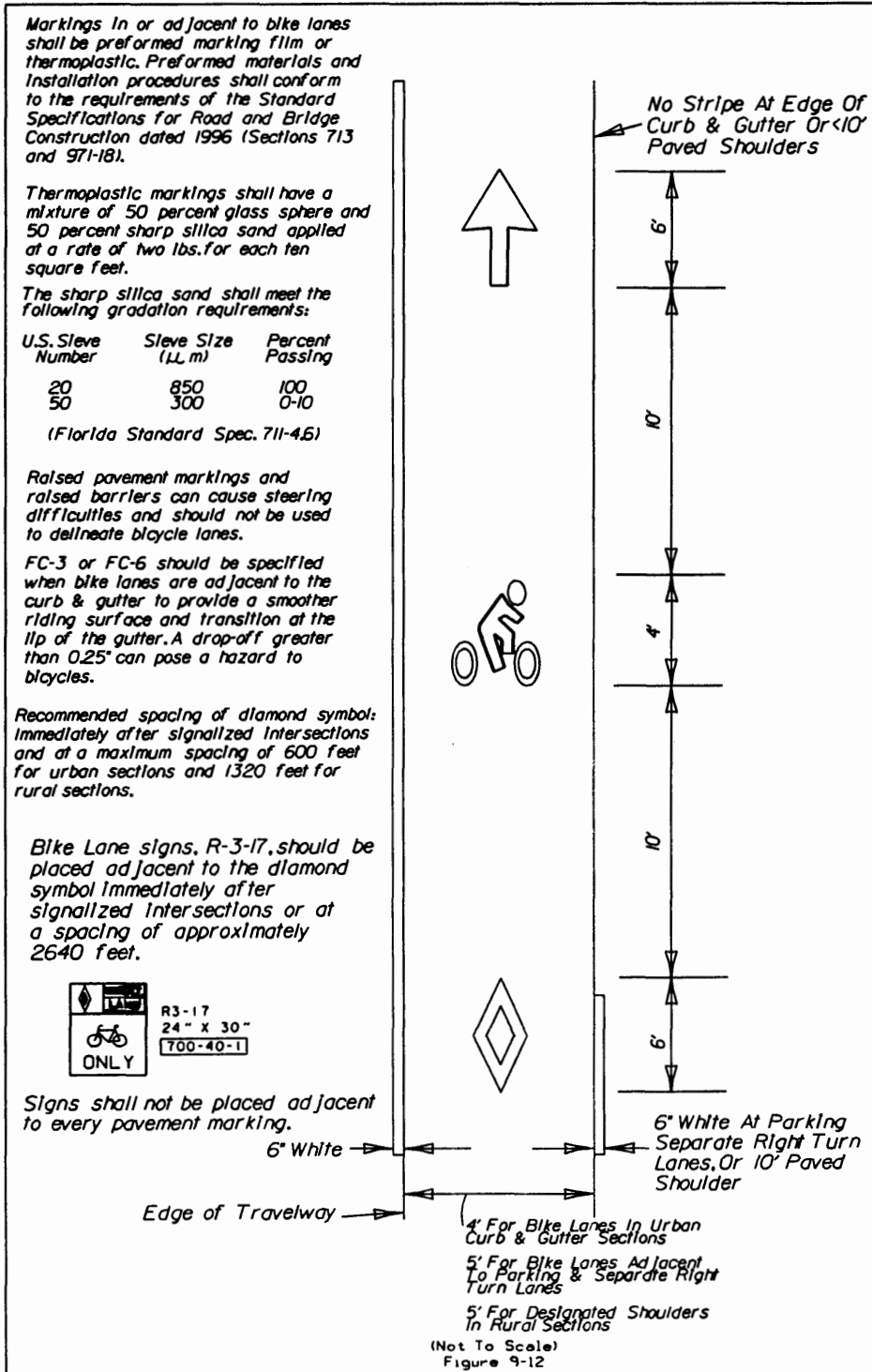

CHAPTER 10

MAINTENANCE

A. INTRODUCTION

In order to provide for the safe and efficient movement of all modes of traffic, it is essential to maintain all aspects of the road and right of way at the highest reasonable level of safety. Improvements consistent with upgrading of safety standards or changes in traffic are also required to maintain the facility in a quality condition. Since maintenance is a costly operation, every effort should be made to provide the maximum safety benefit from each maintenance operation. The fact that a major portion of the maintenance effort is necessary to merely preserve the economic investment in a facility should not be considered as justification for sacrificing the requirements for maintaining or improving the safety characteristics of a street or highway.

B. OBJECTIVES

The major objectives of a maintenance program include the following:

- Maintain all highway features and components in the best possible condition
- Improve sub-standard features, with the ultimate goal to at least meet minimum standards
- Provide for the minimum of disruptions and hazards to traffic during maintenance operations
- Location and reporting of inadequate safety features

C. POLICY

Each highway agency responsible for maintenance shall develop and maintain a program of highway maintenance for the entire highway network under its jurisdiction. This program should include the following activities:

- Identify needs

- Establish priorities
- Establish procedures
- Establish and maintain a regular program of maintenance for all aspects

The program should be regularly evaluated and suitably modified to promote the maintenance of streets and highways in the best practicable condition.

D. IDENTIFICATION OF NEEDS

The identification of maintenance needs is the first stage in the development of a successful maintenance program, and is required when any portion of the highway system is in a sub-standard condition. Action is also required to correct any situation which is hazardous or may become hazardous in the near future. This may be accomplished by both regular inspection of the highway network and proper analysis of accident records.

D.1. Inspection

Periodic and systematic inspection of the entire highway network under each agency's jurisdiction is required to identify situations requiring improvements, and corrections or repairs. These inspections should be conducted by maintenance or traffic operations personnel, or other qualified personnel who are trained in the aspects of highway maintenance requirements.

D.2. Accident Records

A regular program of accident investigations, record keeping, and analysis should be established to provide information for recommended highway modification and corrective maintenance requirements. Cooperation among maintenance, traffic operations, and police agencies is required, and activities of these agencies should be coordinated in accordance with the guidelines set forth in Highway Safety Program Standards Identification and Surveillance of Accident Locations. Inspection of the highway network and analysis of accident records should be utilized to provide feedback for modification of design and construction procedures.

E. ESTABLISHMENT OF PRIORITIES

The maintenance activities determined to be necessary by the identification program should be carried out on a priority basis. The establishment of priorities should be based, to a large extent, upon the objective of promoting highway safety. A high priority should be given to the improvement or correction of situations that may result in fatal or serious crashes. Preservation of highway investment and promotion of efficient traffic operations are important maintenance objectives. Every effort should be made to ensure the highest safety payoff from the maintenance dollar.

F. ESTABLISHMENT OF PROCEDURES

Standard procedures and methods for maintenance operations should be established for efficient, rapid, and safe completion of the required work. All maintenance work shall be conducted in accordance with the Standards set forth in CHAPTER 11 - WORK SITE SAFETY. Each maintenance agency should develop its own Maintenance Manual or utilize the Maintenance Manuals of the FDOT. Such manuals should specify the methods, procedures, equipment, personnel qualifications, and other aspects of the work necessary to ensure successful completion of maintenance operations. Procedures should be developed for emergency, routine, and special operations.

F.1. Emergency Maintenance

Emergency maintenance operations are those required to immediately restore the highway to a safe condition. Emergency maintenance work should be carried out by personnel who are specially trained and qualified. Work units, which should be available on a twenty-four hour basis, should be connected with the emergency response communications system. Emergency operations would include the following:

- The removal of debris from accidents, cargo spillage, or other causes. This activity should be conducted in accordance with the guidelines set forth in Highway Safety Program Standard 16, Debris Hazard Control and Cleanup.
- Replacement of inoperative traffic control devices
- Repair or replacement of damaged highway safety components such as lighting, traffic control devices, redirection, and energy absorbing devices
- Repair or correction of any situation that provides an immediate or

unexpected hazard to the public

- Assistance in any activity during emergency response operations

F.2. Routine Maintenance

Routine maintenance operations are those that may be predicted and planned in advance. These operations, which may be preventive or corrective in nature, should be conducted on a regularly scheduled basis using standard procedures. Proper scheduling of these operations should be utilized to provide minimum disruptions and hazards to the driving public. Routine maintenance would include operations such as:

- Cleaning and debris removal from the pavement, shoulders, and roadside clear zones
- Mowing and other vegetation control operations to provide a smooth recovery area and to maintain proper sight distance
- Cleaning and inspection of gutters, ditches, and other drainage structures
- Structural inspection and preventive maintenance on bridges and other structures
- Cleaning, replacement, and maintenance of roadway lighting fixtures
- Replacement and maintenance of traffic control devices
- Inspection and maintenance of redirection and energy absorbing devices (CHAPTER 4 - ROADSIDE DESIGN)
- Inspection and maintenance of emergency response communication systems and access facilities
- Inspection and maintenance of pavement and shoulders, with particular emphasis on maintaining shoulders flush with the pavement (CHAPTER 5 - PAVEMENT DESIGN, CONSTRUCTION AND MAINTENANCE)
- Inspection and maintenance of all highway components and safety features
- Inspection and maintenance of pedestrian pavements, crossings, etc., with particular emphasis on meeting the intent of ADA

F.3. Special Maintenance

Special maintenance operations are defined as those projects that are neither urgent or routine in nature, but are occasionally required to improve or maintain a street or highway in a quality condition. Since these projects can be planned in advance of the initiation of any work, procedures that provide for efficient, rapid, and safe operations can be developed. To avoid continuing disruptions of traffic, the quality and durability of these improvements, corrections, and repairs should be maintained at the highest practicable level. Special maintenance should include the upgrading of the highway safety features, as well as the repair or replacement of damaged or deteriorated highway components. These operations should be designed to upgrade or maintain the street or highway in accordance with the Standards presented in this Manual.

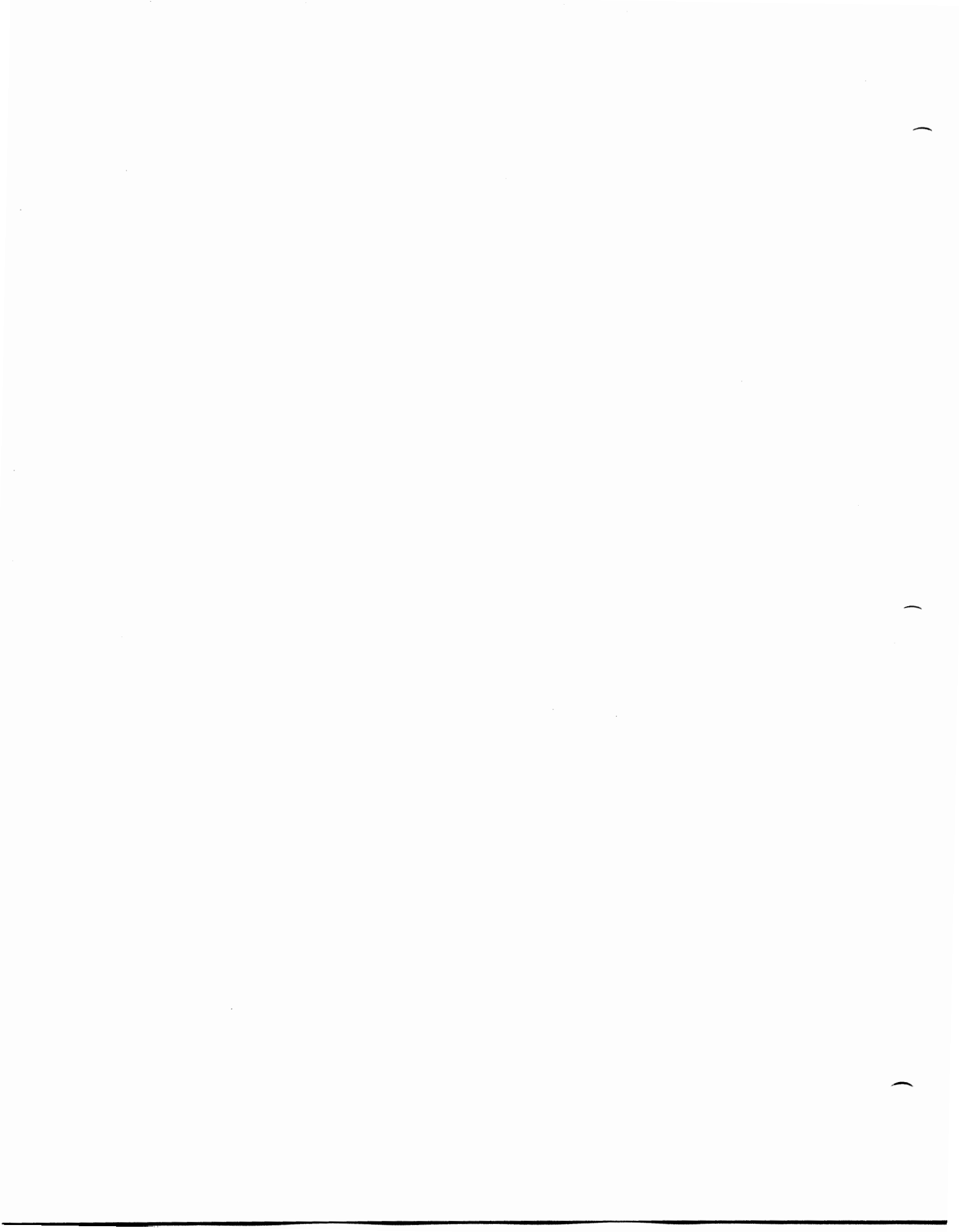

CHAPTER 11

WORK SITE SAFETY

A. INTRODUCTION

Construction, maintenance, and utility operations produce serious highway safety problems. The changes in normal traffic flow and the unexpected conditions at many work sites provide hazardous situations and serious traffic conflicts. A comprehensive plan for work site safety is required to minimize the effects of these construction and maintenance operations.

B. OBJECTIVES

The general objectives of a program of work site safety is to protect workers, pedestrians, bicyclists and motorists during construction and maintenance operations. This general objective may be achieved by meeting the following specific objectives:

- Provide adequate advance warning and information regarding upcoming work sites
- Provide the driver clear directions to understanding the situation he will be facing as he proceeds through or around the work site
- Reduce the consequences of an out of control vehicle
- Provide safe access and storage for equipment and material
- Promote speedy completion of projects (including thorough cleanup of the site)
- Promote use of the appropriate traffic control and protection devices
- Provide safe passageways for pedestrians through, in, and/or around construction or maintenance work sites

C. POLICY

Each highway agency with responsibilities for construction, maintenance, and operation of streets and highways shall develop and maintain a program of work site safety, as set forth in the MUTCD, (Rule 14-15.010) as published by the Federal Department of Transportation (Federal Highway Administration). Additional guidance may be obtained from the FDOT's Roadway and Traffic Design Standards and the Standard Specifications for Road and Bridge Construction.

D. PLANNING OF OPERATIONS

The achievement of work site safety requires careful and complete planning prior to the initiation of any work project. The planning objective is to develop a complete operational plan which would include consideration of the following:

D.1. Project Requirements

D.1.a. Type of Operation

Construction and maintenance projects may be classified as routine, emergency, or special operations.

D.1.a.1. Routine Operations

Routine operations would involve projects such as mowing, street cleaning, and preventive maintenance operations conducted on a regularly scheduled basis.

D.1.a.2. Emergency Operations

Emergency operations require prompt, efficient action to restore the roadway to a safe condition. These include operations such as clearing storm or crash debris, repairing or replacing damaged highway safety components and restoring inoperative traffic control devices.

D.1.a.3. Special Operations

Special operations are defined as those projects neither routine nor emergency in nature, but are occasionally required to maintain or upgrade a street or highway. These include any construction, maintenance, utility, or other operation producing a hazard to workers, pedestrians, or motorists. Any activity involving encroachment upon the highway right of way by workers, equipment, or material storage and transfer shall be subjected to the requirements of work site safety.

D.1.b. Nature of Work

The development of the operation plan for work site safety should include consideration of the following factors:

- Time span required
- Requirements for continuous operation or occupation of the work site
- Capability of clearing the site during cessation of work activity
- The various construction methods, equipment, and procedures that may be utilized. Evaluation of alternate methods should be undertaken to determine the safest and most efficient procedures.
- The necessity for storing equipment or material in the highway right of way
- Operations that may expose workers to hazards from through traffic
- Hazards to out of control vehicles such as excavations or unguarded structures or equipment
- Site conditions that may be confusing or distracting to the driver or produce sight distance problems
- Particular problems associated with night safety
- Equipment inspection and preventive maintenance program

D.1.c. Nature of Work Site

The nature of the work site and the prevailing traffic conditions should, to a large degree, influence the procedures incorporated into the operation plan for work site safety. A determination of the normal vehicle speeds and traffic volumes is essential. The distribution of traffic with respect to time (hour, day, etc.) and direction is also important for establishing traffic control procedures.

D.2 Work Scheduling

Proper work scheduling and sequencing of operations will not only promote efficiency, but also improve the safety aspects of construction and maintenance operations. Where feasible, routine operations and special projects should be conducted during periods of low traffic volume to reduce conflicts. Projects that may be carried out concurrently at the same site should be scheduled simultaneously to eliminate successive disruptions of traffic. Major projects that impede or restrict traffic flow should be coordinated and sequenced with similar projects in adjacent areas, to produce a minimum of disruption to orderly traffic flow in the overall highway network. The scheduling of work at a given location should include consideration of traffic generation (including special events), as well as traffic restrictions by work activities on the surrounding highway network.

D.3. Traffic Control and Protection

The plans for traffic control around or through work sites should be developed with safety receiving a high priority. The plans should include protection at work sites when work is in progress and when operations have been halted (such as during the night). Provisions for the protection of work crews, traffic control personnel, pedestrians, and motorists shall be included in the operation plans. In all cases, the operation plan for traffic control and protection shall include provisions for the following:

- Advance warning
- Clear view of work site
- Roadway delineation
- Regulatory information

- Hazard warning
- Barriers
- Pedestrian safety
- Access
- Location of vehicles and equipment
- Night safety (CHAPTER 6 - ROADWAY LIGHTING)
- Personnel training
- Traffic control and protective devices

D.4. Coordination with Other Agencies

To ensure safe and efficient construction and maintenance operations, the operation plan should be developed and executed in cooperation with all interested individuals and agencies including the following:

- Highway agencies
- Police agencies
- Emergency agencies
- Contractors
- Utilities
- Building departments
- Mass transit agencies
- Traffic generators
- Local residents
- Neighboring jurisdictions

E. WORK SITE OPERATIONS

Construction and maintenance projects should follow the operation plan and should include:

E.1. Public Information

All reasonable effort should be made to inform the public of the location, duration, and nature of impending construction of maintenance projects.

E.2. Contracts and Permits

For construction and reconstruction projects, the general work site layout; traffic control and protection procedures; occupational safety and health requirements; and specific traffic control devices required should be incorporated in the contract plans and specifications.

New utility installations in public rights of way are prohibited unless a permit by the appropriate highway agency is issued. Permits for routine maintenance (e.g. deteriorated pole/equipment replacement), minor alterations (e.g. changes in cable, wire, or transformer size), service drops, or emergency work should generally not be required. Any construction by utility companies involving encroachment of the highway right of way by workers, equipment, material storage and transfer, or other hazardous conditions shall be conducted in accordance with the requirements for work site safety and the Occupational Safety and Health Administration (OSHA).

E.3. Inspection and Supervision

A regular program of inspection and supervision of all construction and maintenance projects shall be established and executed.

F. EVALUATION OF PROGRAM

The entire program for work site safety should be periodically evaluated and revised to provide the safest practicable environment for workers, pedestrians, and motorists during construction and maintenance operations.

CHAPTER 12

CONSTRUCTION

A. INTRODUCTION

The purpose of this Chapter is to establish guidelines for field procedures, as they pertain to control of construction projects, supervision, and contract administration. All construction projects require an inspection process to administer the contract, to certify the project has been constructed within reasonable conformance with the plans/specifications, and the materials which were incorporated into the project were properly tested/certified.

All construction projects require:

- An inspection procedure to administer the contract
- Certification

B. OBJECTIVES

Construction of street and highway facilities is the result of the effort, of the engineer, the contractor, and the owner. Minimum construction Standards shall be followed to provide for proper implementation of the design. The following general objectives for roadway construction should be followed to ensure proper construction:

- All construction performed and all materials utilized shall be in reasonably close conformity with the construction plans and contract documents.
- The responsibilities and obligations of the owner, engineer, and contractor should be clearly defined.
- A safe working environment shall be provided in accordance with CHAPTER 11 - WORK SITE SAFETY.
- Adequate procedures through established methods of sampling and testing shall be implemented to provide for the control and placement of materials.

C. CONTROL OF THE WORK

C.1. Plans and Contract Documents

The Contractor will be furnished an appropriate number of copies of the plans and special provisions as required for the particular project. The Contractor shall have available at the work site, at all times, one copy each of the plans (including relevant Design Standards), Specifications, and Special Provisions.

C.1.a. Plans

The plans furnished consist of general drawings showing such details which are necessary to give a comprehensive idea of the construction contemplated. Roadway plans will show, in general, alignment, profile grades, typical cross sections, and general cross sections as necessary. Structure plans, in general, will show in detail all dimensions of the work contemplated.

C.1.b. Alterations in Plans

No changes shall be made on any plan or drawing after it is approved by the Engineer, except as authorized in writing by the Engineer. All authorized alterations affecting the requirements and information given on the approved plans shall be in writing.

C.1.c. Working Drawings (for Structures)

C.1.c.1. General

The Contractor shall furnish such working, shop, and erection drawings, as may be required, to complete the structure in compliance with the design shown on the plans.

C.1.c.2. Submission of Working, Shop, and Erection Drawings

All working, shop, and erection drawings prepared by the Contractor or his agents (subcontractor, fabricator, supplier, etc.) shall be reviewed, dated, stamped, approved, and signed by the Contractor prior to submission to the Engineer of Record for review. The

Contractor's signed approval of drawings submitted shall confirm he has verified the work requirements, field measurements, construction criteria, sequence of assembly and erection, access and clearances, catalog numbers, and other similar data. Each series of drawings shall indicate the specification section and page or drawing number of the contract plans to which the submission applies. The Contractor shall indicate on the working, shop, and erections drawings all deviations from the contract drawings and shall itemize all deviations in his letter of transmittal.

C.1.c.3. Responsibility for Accuracy of Working Drawings

It is understood that approval by the Engineer of the Contractor's working drawings does not relieve the Contractor of any responsibility for accuracy of dimensions and details, or for conformity of dimensions and details. The Contractor shall be responsible for agreement and conformity of his working drawings with the approved plans and specifications.

C.2. Coordination of Plans, Specifications, and Special Provisions

The specifications, plans, special provisions, and all supplemental documents are integral parts of the contract, and a requirement occurring in one is as binding as though occurring in all. They are to be complementary and to describe and provide for a complete work.

In cases of discrepancy, the governing order of the documents shall be as follows:

- Special Provisions
- Plans
- Standard Drawings
- Specifications

C.3. Conformity of Work with Plans

All work performed and all materials furnished shall be in reasonably close conformity with the lines, grades, cross sections, dimensions, and material

requirements, including tolerances, shown on the plans or indicated in the specifications.

In the event the Engineer finds the materials or the finished product in which the materials are used not within reasonably close conformity with the plans and specifications, but reasonably acceptable work has been produced, he shall then make a determination if the work shall be accepted and remain in place. In this event, the Engineer will document the basis of acceptance by contract modification which will provide for an appropriate adjustment in the contract price for such work or materials as he deems necessary to conform to his determination based on engineering judgment.

In the event the Engineer finds the materials, or the finished product in which the materials are used, or the work performed, are not in reasonably close conformity with the plans and specifications and have resulted in an inferior or unsatisfactory product, the work or materials shall be removed and replaced or otherwise corrected by and at the expense of the Contractor.

C.4. Conformity of Work Shown in Regulatory Permits

All work shall be accomplished in accordance with special conditions of the regulatory permits.

C.5. Authority of the Engineer

All work shall be performed to the satisfaction of the Engineer.

C.6. Engineering and Layout

C.6.a. Control Points Furnished

Horizontal and vertical control points are required at appropriate intervals along the line of the project to facilitate the proper layout of the work. The Contractor shall preserve all control points furnished.

C.6.b. Layout of Work

Utilizing the control points furnished, all horizontal and vertical controls shall be established as necessary to construct the work in conformance with the plans and specifications. The work shall include performing all calculations

required and setting all stakes needed, such as grade stakes, offset stakes, reference point stakes, slope stakes, and other reference marks or points necessary to provide lines and grades for construction of all roadway, bridge, and miscellaneous items.

C.6.c. Personnel, Equipment, and Record Requirements

The Contractor shall employ only competent personnel and utilize only suitable equipment in performing layout work.

Adequate field notes and records shall be kept as layout work is accomplished. These field notes and records shall be available for review by the Engineer as the work progresses and copies shall be furnished to the Engineer at the time of completion of the project. Any inspection or checking of the Contractor's field notes or layout work by the Engineer, and the acceptance of all or any part thereof, shall not relieve the Contractor of his responsibility to achieve the lines, grades, and dimensions shown in the plans and specifications.

C.7. Contractor's Supervision

C.7.a. Prosecution of Work

The Contractor shall give the work the constant attention necessary to assure the scheduled progress and he shall cooperate fully with the Engineer and with other Contractors at work in the vicinity.

C.7.b. Contractor's Superintendent

The Contractor shall at all times have on the work site, as his agent, a competent superintendent capable of thoroughly interpreting the plans and specifications and thoroughly experienced in the type of work being performed, and who shall receive the instructions from the Engineer or his authorized representatives. The superintendent shall have full authority to execute the orders or directions of the Engineer and to supply promptly any materials, tools, equipment, labor, and incidentals which may be required. Such superintendence shall be furnished regardless of the amount of work sublet.

C.7.c. Supervision for Emergencies

The Contractor shall have a responsible person available at or reasonably near the work site on a twenty-four hour basis, seven days a week, in order that he may be contacted in emergencies and in cases where immediate action must be taken to maintain traffic or to handle any other problems that might arise. The Contractor shall be responsible for initiating, installing, and maintaining all traffic control devices as described in CHAPTER 11- WORK SITE SAFETY and in the plans.

C.8. General Inspection Requirements

C.8.a. Cooperation by Contractor

No work shall be done nor materials used without suitable supervision or inspection by the Engineer. The Contractor shall furnish the Engineer with every reasonable facility for ascertaining whether the work performed and materials used are in accordance with the requirements and intent of the plans and specifications.

C.8.b. Failure of Engineer to Reject Work During Construction

If, during or prior to construction operations, the Engineer should fail to reject defective work or materials, whether from lack of discovery of such defect or for any reason, such initial failure to reject shall in no way prevent his later rejection when such defect is discovered.

C.9. Final Construction Inspection Maintenance until Final Acceptance

The Contractor shall maintain all work in first-class condition until it has been completed as a whole and has been accepted by the Engineer. When all materials have been furnished, all work has been performed, and the construction contemplated by the contract has been satisfactorily completed, the Engineer will make the final inspection.

D. CONTROL OF MATERIALS

D.1. Source of Supply and Quality Requirements

D.1.a. Only Approved Materials to be Used

Only materials conforming to the requirements of the specifications and approved by the Engineer shall be used in the work. Any materials proposed for use may be inspected or tested at any time during their preparation and use. No material which, after approval, has in any way become unfit for use, shall be used in the work.

D.2. Inspection and Tests at Source of Supply

D.2.a. General

The Engineer may undertake the inspection of materials at the source of supply.

D.2.b. Cooperation by Contractor

The Contractor shall assure the Engineer has free entry at all times to such parts of the plant as concern the manufacture or production of the materials ordered, and shall bear all costs incurred in providing all reasonable facilities to assist in determining whether the material furnished complies with the requirements of the specifications.

D.3. Control by Samples and Tests

D.3.a. Materials to be Tested, Samples

The Engineer may require any or all materials to be subjected to tests by means of samples or otherwise, at production points, after delivery, or both, as he may determine.

D.3.b. Applicable Standards

Methods of sampling and testing materials shall conform to the Engineer's requirements and should be in accordance with Florida Methods so far as

covered therein. Otherwise, they should be in accordance with Standards of AASHTO, ASTM, or other criteria as specifically designated by the Engineer. Where an AASHTO, ASTM, or other non-Florida Method is designated, but a Florida Method which is similar exists, sampling and testing should be in accordance with the Florida Method.

Whenever in these Specifications, Florida, AASHTO, ASTM, or other Standards are referenced without identification of the specific time of issuance, the reference should be construed to mean the most current issuance, including interims or addendums thereto, at the time of advertisement for bids for a project.

D.4. Quality Control System

D.4.a. General Requirements

The Contractor shall furnish and maintain a quality control system that will provide reasonable assurance that all materials and products submitted for acceptance conform to the contract requirements, whether manufactured or processed by the Contractor or procured from suppliers or subcontractors. The Contractor shall perform or have performed the inspection, and tests required to substantiate product conformance to contract requirements and shall also perform or have performed all inspections and tests otherwise required by the contract.

D.4.b. Documentation

The Contractor shall maintain adequate records of all inspections and tests. The records shall indicate the nature and number of tests made, the number and type of deficiencies found, the quantities approved and rejected, and the nature of corrective action taken, as appropriate.

D.4.c. Corrective Actions

The Contractor shall take prompt action to correct any errors, equipment malfunctions, process changes, or other assignable causes which have resulted or could result in the submission of materials, products, and completed construction which do not conform to the requirements of the specifications.

CHAPTER 13

PUBLIC TRANSIT

A. INTRODUCTION

All usual modes of transportation (autos, trucks, transit vehicles, rails, aircraft, water craft, bikes, pedestrian) should be considered when planning, designing, and constructing the surface transportation system. Where there is a demand for highways to serve vehicles, there could also be a demand for public transit or public transportation. Public transit should be considered in all phases of a project, including planning, preliminary design and engineering, design, construction, etc. With the recent passing of various legislation, multimodalism is the ultimate goal.

Planning and designing for public transit is important because it is an integral part of the overall surface transportation system. Public transit is defined as passenger transportation service, local or regional in nature, that is available to any person who pays a prescribed fare. It operates on established schedules along designated routes or lines with specific stops and is designed to move relatively large numbers of people at one time. Public transit includes bus, light rail, and rapid transit. Public transportation is similar in definition because it serves the general public, it also includes non-fixed route services that are door-to-door or paratransit services.

With rising levels of congestion resulting in the use of new strategies to effectively and efficiently manage mobility, there is an increased demand for accessible and user friendly public transit. New strategies include increased emphasis on public transit and new emphasis on transportation system management (TSM), as well as transportation demand management (TDM). TSM is the use of low cost capital improvements to increase the efficiency of roadways and transit services such as, retiming traffic signals or redesignating traffic flow. TDM focuses on people reducing the number of personal vehicle trips, especially during peak periods. TDM includes the promotion of alternatives to the single occupant vehicle, including public transportation, carpooling, vanpooling, bicycling, walking, telecommuting, as well as other methods for reducing peak hour travel.

Federal and State legislation provide the stimulus for planning, designing, and constructing a fully integrated transportation system benefitting the traveling public and the environment. Examples of legislation include The Intermodal Surface Transportation Efficiency Act of 1991 (ISTEA), The Americans with Disabilities Act of 1990 (ADA), and The Clean Air Act Amendment of 1990 (CAAA). In response to this legislation, the surface transportation system should provide for concurrent use by automobiles, public transit and rail, and to the extent possible, bicycles and pedestrians.

Throughout the entire process, coordination with transit as if it were a utility is essential.

B. OBJECTIVE

There are a number of methods to efficiently develop a coordinated surface transportation system. Coordination among agencies is necessary during the planning and design stages to incorporate transit needs and during the construction phase for re-routing bus (and complementary pedestrian) movements and for actual transit agency specific requirements (e.g., bus stop sign replacement, shelter installations, etc.). For planning purposes, the State and Local Transportation Improvement Program (TIP) should be referenced. Additionally, individual transit authorities have five year Transit Development Plans (TDP's) that are updated annually. The TDP can be used as a guide for planned transit needs along existing and new transportation corridors so transit consideration and transit enhancements can be incorporated where appropriate.

C. TRANSIT COMPONENTS

C.1. Stops and Station Areas

Where new stop pads are constructed at bus stops, bays, or other areas where a lift or ramp is to be deployed, they shall have a firm, stable surface, minimum clear length of 96 inches (measured from the curb or vehicle roadway edge), minimum clear width of 60 inches (measured parallel to the vehicle roadway) to the maximum extent allowed by legal site restraints, and shall be connected to streets, sidewalks, or pedestrian paths by an accessible route. The slope of the pad parallel to the roadway shall, to the extent practicable, be the same as the roadway. For water drainage, a maximum slope of 1:50 (2%) perpendicular to the roadway is allowed. In cases where there are no sidewalks or curbs, passenger pads may be necessary to allow the wheelchair passengers to board or alight from a transit vehicle. Coordination with the Public Transportation Office and/or local public transit provider(s) is necessary.

C.2. Shelters

Every public transit system has different needs with regards to shelters and corresponding amenities (e.g., benches, information kiosks, leaning posts, trash receptacles, etc.). Shelter foundation and associated pad size vary from stop to stop based on right of way availability, line of sight, facility usage, etc. Where provided, new or replaced bus shelters shall be installed or positioned as to permit a wheelchair or mobility aid user to enter from the public way and to reach a location

therein having a minimum clear floor area of 30 inches by 48 inches, entirely within the perimeter of the shelter. Such shelters shall be connected by an accessible route to the boarding area provided under C.1 Stops and Station Areas, this Chapter. Coordination with the Public Transportation Office and local transit provider(s) is necessary.

C.3. Benches

Bench placement should be in an accessible location (i.e., not on the far side of a drainage ditch from the actual bus stop), but appropriately out of the path of travel on a sidewalk. Connection between the sidewalk and/or passenger pad should be provided. Coordination with the Public Transportation Office and the local public transit provider(s) is necessary.

C.4. Concrete Bus Pads

Although not always practical, there are situations where concrete bus pads should be incorporated into the pavement design of a project. Frequent stopping transit vehicles in a particular location is an example where concrete pads may be warranted.

C.5. Bus Bays (Pullout or Turnout Bays)

In some situations, turnout bays for transit vehicles are appropriate (i.e., consistent slow boarding, layover needs, safety reasons, high speed traffic, etc.). Bus bays can be designed for one or more buses. Coordination with the Public Transportation Office and/or the local public transit provider(s) will help determine the need for and justification of bus bays. When possible, bus bays should be located on the far side of a signalized intersection. The traffic signal will create the critical gap needed for bus re-entry into traffic. There are several publications available which provide additional design information for transit system applications. The FDOT District Public Transportation Office(s) maintain a library of these publications.



CHAPTER 14

DESIGN EXCEPTIONS

A. GENERAL

Uniform minimum standards for design, construction, and maintenance of streets and highways are contained in this Manual and meet the minimum values established by AASHTO. Consequently, the values given govern the design process. When it becomes necessary to deviate from the Manual's criteria, early documentation and approval is required. This chapter will provide the process for documentation and approval of Design Exceptions. When the Manual's criteria are met, no Design Exception is required.

To expedite the approval of these deviations, it is important the correct approval process be followed. The design project file should clearly document the action taken and approval given.

B. DESIGN EXCEPTIONS

Design Exceptions are required when any of the Manual's criteria for the 13 controlling Design Elements listed below cannot be met.

1. Design Speed
2. Lane Widths
3. Shoulder Widths
4. Bridge Widths
5. Structural Capacity
6. Vertical Clearance
7. Grades
8. Cross Slopes
9. Superelevation
10. Horizontal Alignment
11. Vertical Alignment
12. Stopping Sight Distance

13. Horizontal Clearance

If the County or Municipality has adopted by ordinance design criteria for local subdivision roads, compliance with those regulations is an approved design exception.

C. RECOMMENDATIONS FOR AND APPROVAL OF DESIGN EXCEPTIONS

Design Exceptions are recommended by the Professional Engineer responsible for the project design elements. A public or private utility may submit to the maintaining authority a completed exception package for work designed by the utility's forces. However, if the design is by others, the package must be submitted, signed and sealed by a professional engineer registered in the State of Florida.

All Design Exceptions require approval from the maintaining authority's (county or municipality) designated Registered Professional Engineer representative with project oversight or general compliance responsibilities.

Any Design Exception that involves a State or Federal facility must be processed through the FDOT's local District Design Engineer who will then follow FDOT processes for concurrence and approval by FHWA, if necessary.

The Department's Utility Accommodation Manual provides guidance on exceptions with respect to utilities.

D. COORDINATION OF DESIGN EXCEPTIONS

In order to allow time to research alternatives and begin the analysis and documentation activities, it is critical that Design Exceptions be identified as early in the process as possible. This is preferably done during the planning phases of projects or as soon as possible in the initial design efforts.

When the need for a Design Exception has been determined, the Responsible Professional Engineer must coordinate with the maintaining authority and FDOT (if applicable), to obtain conceptual concurrence providing any required documentation requested.

E. JUSTIFICATION AND DOCUMENTATION OF DESIGN EXCEPTIONS

The objective of the justification of Design Exceptions is to demonstrate the impacts on the operation and safety of the facility are acceptable compared to the impacts and added benefits of meeting the criteria. All Design Exception requests shall include documentation sufficient to justify the request and independently evaluate the operational and safety impacts. Any request for a Design Exception should address the following issues applicable to the element in question:

Description:

- a) Project description (general information, typical section, etc.)
- b) Description of Design Exception (specific project conditions related to Design Exception, controlling design element, acceptable Manual value, and proposed value for project)
- c) The compatibility of the design and operation with the adjacent sections

Operational Impacts:

- a) Amount and character of traffic using facility
- b) Effect on capacity of the deviation (proposed criteria vs. Manual using an acceptable capacity analysis procedure and calculate reduction for design year, level of service)

Safety Impacts:

- a) Crash history and analysis (location, type, severity, relation to the Design Exception element)
- b) Impacts associated with proposed criteria (annualized value of expected economic loss associated with crashes)

Benefit/Cost Analysis:

Calculate a benefit/cost analysis which estimates the cost effectiveness of correcting or mitigating a substandard design feature. The benefit is the expected reduction in future accident costs and the cost is the direct construction and maintenance costs associated with the design. These costs are calculated and annualized so that direct comparison of alternate designs can be made.

A benefit/cost ratio equal to or greater than 1.0 indicates it is cost effective to implement a particular design; however, the final decision is a management decision which considers all factors. The key factors in the analysis are:

- a) Evaluation of crashes by type and cause
- b) Estimate of crash costs (based on property damage and severity of injuries)
- c) Selection of a crash reduction factor
- d) Selection of a discount rate
- e) Estimate of construction and maintenance costs
- f) Selection of life of the improvements
- g) Period of time over which the benefits will be realized

NOTE: Chapter 2 of the AASHTO Roadside Design Guide and the FHWA Technical Advisory titled "Motor Vehicle Accident Costs" dated October 31, 1994, provides guidance for the benefit/cost analysis, and may be considered.

Conclusion and Recommendation:

- a) The cumulative effect of other deviations from design criteria
- b) Safety mitigating measures considered and provided
- c) Summarize specific course of action

F. FINAL PROCESSING OF DESIGN EXCEPTIONS

After conceptual approval has been obtained from the maintaining authority's designee and the documentation justifying the Design Exception is signed by the Responsible Professional Engineer and forwarded as per the sample request letter **EXHIBIT 14 - A** to the maintaining authority's designated Registered Professional Engineer, the Design Exception will be reviewed for completeness and adherence to the requirements of Sections D and E, this Chapter.

If the Design Exception complies with all requirements, the approval will be signed by the maintaining authority's designated Registered Professional Engineer; and, if applicable, forwarded to the FDOT's local District Design Engineer for concurrence.

When all signatures are obtained, the Design Exception will be returned to the Responsible Professional Engineer. A copy will be retained by the maintaining agency and FDOT, if applicable.

TO: _____

DATE: _____

SUBJECT: **DESIGN EXCEPTION**

Local road number or street name: _____

Project description (limits): _____

Type construction (new, rehab, adding lanes, resurfacing, etc.) _____

State and/or Federal road number (if applicable): _____

DESIGN EXCEPTION FOR THE FOLLOWING ELEMENT:

- | | | | |
|--|---|---|--|
| <input type="checkbox"/> Design speed | <input type="checkbox"/> Lane widths | <input type="checkbox"/> Shoulder widths | <input type="checkbox"/> Bridge widths |
| <input type="checkbox"/> Structural capacity | <input type="checkbox"/> Vertical clearance | <input type="checkbox"/> Grades | <input type="checkbox"/> Cross slope |
| <input type="checkbox"/> Superelevation | <input type="checkbox"/> Horizontal alignment | <input type="checkbox"/> Vertical alignment | |
| <input type="checkbox"/> Stopping sight distance | <input type="checkbox"/> Horizontal clearance | | |

Include a brief statement concerning the project and items of concern.

Attach all supporting documentation to this exhibit in accordance with **SECTION 14 - F**.

Recommended by: _____

(Responsible Professional Engineer)

Approval: _____

(Maintaining authority's designated Professional Engineer)

Concurrence: _____

FDOT/FHWA (if applicable)

EXHIBIT 14 - A

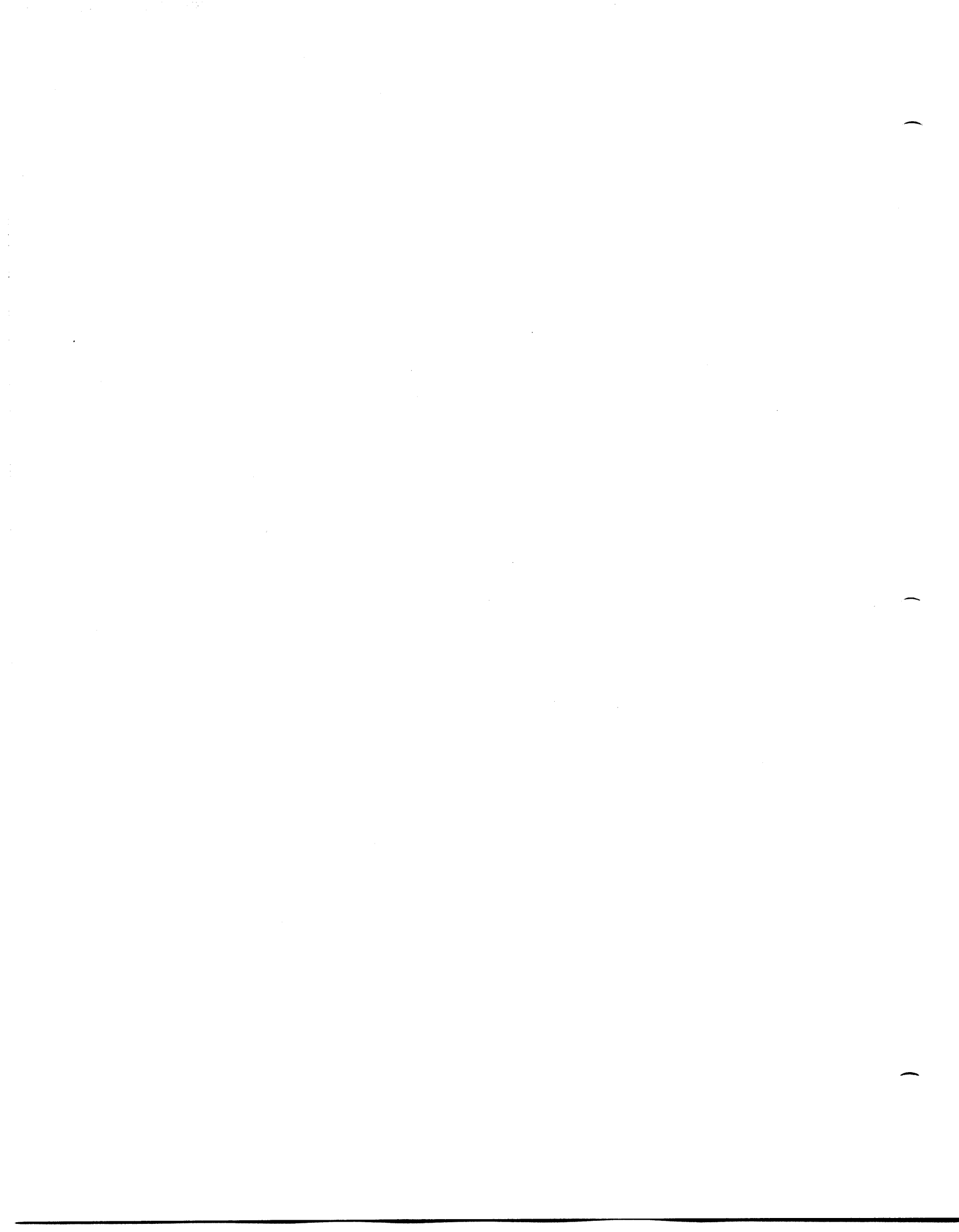

INDEX

- acceleration
Ch. 3: 6, 30-32, 35, 37, 39, 40, 42, 46, 47; **Ch. 6:** 3; **Ch. 7:** 6
- access control
Ch. 1: 1, 5, 7; **Ch. 2:** 1, 4, 5, 9; **Ch. 3:** 28, 31-34, 39, 41, 45, 46; **Ch. 7:** 6
- alignment
Ch. 1: 1, 2; **Ch. 2:** 1, 4; **Ch. 3:** 1, 6, 7, 9-15, 21, 35, 42, 43, 46, 54; **Ch. 7:** 3-5;
Ch. 8: 7; **Ch. 9:** 5; **Ch. 12:** 2; **Ch. 14:** 4, 9
- arterial
Ch. 1: 5, 6; **Ch. 2:** 2, 3; **Ch. 3:** 5, 30, 42, 50; **Ch. 9:** 1
- auxiliary lane
Ch. 3: 32
- barriers
Ch. 3: 7, 18, 20-22, 24, 27, 43, 44, 47, 54; **Ch. 4:** 1, 6-10; **Ch. 6:** 5, 6; **Ch. 8:** 3
- bicycle facilities
Ch. 2: 4, 6, 8; **Ch. 3:** 18, 25, 50, 51; **Ch. 9:** 4, 6
- bicycle lane
Ch. 3: 27; **Ch. 9:** 2
- border
Ch. 4: 4
- braking
Ch. 5: 1
- bridges
Ch. 3: 25, 27, 51, 54; **Ch. 4:** 7, 8
- bus benches
Ch. 3: 51
- buses
Ch. 3: 6, 13; **Ch. 9:** 2; **Ch. 13:** 3

capacity

Ch. 1: 2, 5-7; **Ch. 2:** 1, 2, 4, 6; **Ch. 3:** 8, 9, 15, 18, 24, 28, 30, 31, 33, 52-54;
Ch. 6: 1; **Ch. 8:** 4; **Ch. 9:** 1; **Ch. 14:** 4, 6, 9

channelization

Ch. 3: 29, 34, 45, 46

channels

Ch. 3: 22

classifications

Ch. 1: 5; **Ch. 3:** 29

clear zones

Ch. 2: 1; **Ch. 3:** 1, 25, 34, 39, 44; **Ch. 4:** 3; **Ch. 7:** 5; **Ch. 10:** 4

clearances

Ch. 3: 6, 43; **Ch. 4:** 6; **Ch. 12:** 3

climbing lanes

Ch. 3: 13, 39

collector

Ch. 1: 5; **Ch. 2:** 2, 3; **Ch. 3:** 31, 46, 50; **Ch. 6:** 3; **Ch. 9:** 1, 3

construction

Ch. 1: 1, 3, 7, 8; **Ch. 2:** 1, 2, 6, 7; **Ch. 3:** 2, 7, 15, 16, 18-20, 25, 26, 31, 32, 36, 42,
48-50, 52-54; **Ch. 4:** 1, 7, 8; **Ch. 5:** 1-4; **Ch. 6:** 2; **Ch. 9:** 1, 6; **Ch. 10:** 2, 4; **Ch. 11:** 6,
1-6; **Ch. 12:** 1-3, 5, 6, 8; **Ch. 13:** 1, 2; **Ch. 14:** 4, 6, 7, 9

control devices

Ch. 1: 8; **Ch. 3:** 1, 4, 28, 45, 52, 54; **Ch. 6:** 4, 6; **Ch. 7:** 1, 2, 6; **Ch. 8:** 5; **Ch. 10:** 3, 4;
Ch. 11: 2

control of access

Ch. 2: 1, 3-5, 8; **Ch. 3:** 22, 28, 31, 32, 54

coordination

Ch. 1: 6, 3, 6-9; **Ch. 2:** 1, 6, 7; **Ch. 3:** 1, 14, 43; **Ch. 4:** 9; **Ch. 8:** 1; **Ch. 11:** 5;
Ch. 12: 3; **Ch. 13:** 2, 3; **Ch. 14:** 5

crash cushions

Ch. 4: 4, 8, 12

cross section

Ch. 2: 1; **Ch. 3:** 12, 15, 25, 26, 39, 42-44; **Ch. 4:** 3, 7; **Ch. 5:** 2; **Ch. 7:** 4; **Ch. 8:** 5

cross slope

Ch. 3: 12, 13, 16-18, 21, 45, 49; **Ch. 7:** 5; **Ch. 14:** 9

crosswalks

Ch. 3: 35, 49, 50, 55; **Ch. 8:** 3, 5

crown

Ch. 3: 12, 45; **Ch. 7:** 5

culverts

Ch. 3: 22, 27; **Ch. 4:** 5, 6

cul-de-sac

Ch. 3: 26

curb ramps

Ch. 3: 18, 25, 49, 50; **Ch. 8:** 5

curbs

Ch. 3: 24, 45, 47, 49; **Ch. 4:** 6, 8, 10; **Ch. 5:** 3; **Ch. 8:** 5; **Ch. 13:** 2

deceleration

Ch. 3: 30-32, 35, 39-42, 46; **Ch. 4:** 4, 6, 9-12; **Ch. 6:** 3; **Ch. 7:** 6

degree of curvature

Ch. 3: 11, 12

design exception

Ch. 14: 4- 9

design speed

Ch. 3: 3-5, 10, 11, 15, 19, 20, 37, 40-42, 47; **Ch. 4:** 7; **Ch. 7:** 2, 4; **Ch. 9:** 6; **Ch. 14:** 4, 9

divided highways

Ch. 3: 15, 17; **Ch. 4:** 8; **Ch. 7:** 5

driveways

Ch. 2: 5; **Ch. 3:** 11, 18, 29, 33-35, 46; **Ch. 4:** 5-6; **Ch. 9:** 5

energy absorbing devices

Ch. 3: 47, 53; **Ch. 4:** 7, 8, 10, 11; **Ch. 10:** 3, 4

exit lanes

Ch. 3: 40, 41

fencing

Ch. 8: 3

freeways

Ch. 2: 6; **Ch. 3:** 10, 19, 20, 22, 27, 31, 46; **Ch. 4:** 6; **Ch. 6:** 3

friction

Ch. 3: 7, 11, 37; **Ch. 5:** 1

frontage roads

Ch. 2: 7; **Ch. 3:** 25, 26, 54

grade separation

Ch. 3: 30, 31; **Ch. 7:** 1

grades

Ch. 3: 13-15, 18, 33, 41, 43; **Ch. 9:** 5, 6; **Ch. 12:** 2, 3, 5; **Ch. 14:** 4, 9

guardrail

Ch. 3: 24; **Ch. 4:** 1, 3, 7, 8; **Ch. 6:** 5; **Ch. 7:** 6; **Ch. 9:** 1

headlight

Ch. 3: 14, 19, 20, 22; **Ch. 6:** 3

height

Ch. 3: 7, 8, 24, 35, 36; **Ch. 4:** 9; **Ch. 6:** 5; **Ch. 7:** 2

highway

Ch. 1: 1-3, 6, 3, 1, 4-10; **Ch. 2:** 1-8; **Ch. 3:** 1, 2, 4-6, 8-10, 12, 15, 18, 19, 25-28, 32, 33, 35-38, 40, 41, 44, 46, 48, 50-54; **Ch. 4:** 1, 4-6, 8; **Ch. 5:** 1, 4; **Ch. 6:** 1, 2, 4; **Ch. 7:** 1-7; **Ch. 8:** 1, 2, 4, 6, 7; **Ch. 9:** 1, 5; **Ch. 10:** 1-5; **Ch. 11:** 1-6; **Ch. 12:** 1

highway grade crossings

Ch. 7: 1, 2, 5-7

horizontal clearance

Ch. 3: 27; **Ch. 4:** 7; **Ch. 9:** 6; **Ch. 14:** 5, 9

inlets

Ch. 4: 5

interchanges

Ch. 3: 15, 25, 33, 46, 47; **Ch. 6:** 3, 6

intersection

Ch. 2: 5; **Ch. 3:** 6, 9, 21, 25, 27, 28, 30-38, 44-50; **Ch. 4:** 5, 7; **Ch. 7:** 3, 4; **Ch. 9:** 1;
Ch. 13: 3

islands

Ch. 3: 30, 45, 54

land development

Ch. 1: 2; **Ch. 2:** 1, 2, 4-7, 9; **Ch. 3:** 32; **Ch. 8:** 2

landscaping

Ch. 3: 19; **Ch. 4:** 5; **Ch. 8:** 3

lane widening

Ch. 3: 6, 12

lanes

Ch. 2: 6; **Ch. 3:** 6, 8, 13, 15-21, 26, 27, 29-32, 34-36, 38-47, 50, 54; **Ch. 6:** 3-6;
Ch. 9: 1-3, 5; **Ch. 14:** 9

lengths

Ch. 3: 13, 42, 47

level of service

Ch. 1: 2, 4, 6, 7; **Ch. 3:** 15; **Ch. 14:** 6

lighting

Ch. 2: 6; **Ch. 3:** 1, 6, 28, 35-37, 50, 54; **Ch. 4:** 6, 7; **Ch. 6:** 1-7; **Ch. 8:** 4, 6;
Ch. 10: 3-4; **Ch. 11:** 5

mailboxes

Ch. 4: 8

maintenance

**Ch. 1: 1, 3, 7, 8; Ch. 2: 2; Ch. 3: 1, 15-17, 32, 36, 52, 53; Ch. 4: 1, 5, 7; Ch. 5: 1-4;
Ch. 6: 2, 5; Ch. 7: 1, 7; Ch. 8: 1; Ch. 9: 5, 6; Ch. 10: 1-5; Ch. 11: 6; Ch. 14: 4, 6, 7**

markings

Ch. 3: 13, 26, 33, 45, 49, 50; Ch. 7: 6; Ch. 8: 5; Ch. 9: 2

median

**Ch. 2: 5; Ch. 3: 7, 15, 17, 19-22, 26, 27, 29, 38, 45, 53, 54; Ch. 4: 1, 2, 5, 7-9, 12;
Ch. 7: 5**

median barriers

Ch. 3: 7, 20-22, 54; Ch. 4: 9

median openings

Ch. 3: 21, 29, 45

merging

Ch. 3: 13, 26, 35, 39, 40, 46; Ch. 4: 3

new construction

Ch. 3: 2, 18, 54; Ch. 5: 1

parking

Ch. 2: 3, 6; Ch. 3: 16, 24, 36, 51; Ch. 4: 2; Ch. 7: 6; Ch. 8: 2, 4, 6, 7

passing sight distance

Ch. 3: 7, 8, 14

pavement

**Ch. 2: 3; Ch. 3: 1, 2, 6, 11-13, 15, 16, 20-22, 26, 27, 36, 39, 41, 44, 45, 50, 51,
53, 55; Ch. 4: 5, Ch. 5: 1; Ch. 7: 5-7; Ch. 9: 6; Ch. 10: 4; Ch. 13: 3**

pedestrian

**Ch. 1: 1-6; Ch. 2: 8; Ch. 3: 1, 3, 18-20, 24, 25, 30, 32, 34, 35, 48-51, 54, 55;
Ch. 4: 2, 6, 8; Ch. 6: 1, 3, 4; Ch. 8: 1-7; Ch. 11: 5; Ch. 13: 1, 2**

pedestrian traffic

Ch. 1: 1; **Ch. 3:** 18, 48, 50; **Ch. 6:** 1, 3; **Ch. 8:** 1-3, 5, 6

pedestrians

Ch. 1: 2, 8; **Ch. 2:** 5; **Ch. 3:** 1, 4, 17-19, 36, 47-51; **Ch. 4:** 2, 5, 8; **Ch. 6:** 1, 2;
Ch. 8: 1, 4-6; **Ch. 9:** 3, 6; **Ch. 11:** 1, 3, 4, 6; **Ch. 13:** 1

planning

Ch. 1: 1-3, 7, 8; **Ch. 2:** 2, 6, 9; **Ch. 3:** 18, 32, 48; **Ch. 9:** 6; **Ch. 11:** 2; **Ch. 13:** 1, 2;
Ch. 14: 5

protective devices

Ch. 2: 6; **Ch. 4:** 2, 8, 12; **Ch. 7:** 7; **Ch. 11:** 5

radii

Ch. 3: 5, 6, 42, 44; **Ch. 4:** 5

ramps

Ch. 3: 18, 25, 29, 40, 43, 46, 49, 50; **Ch. 6:** 3; **Ch. 8:** 5

reconstruction

Ch. 1: 2, 7, 8; **Ch. 3:** 18, 52-54; **Ch. 7:** 1, 7; **Ch. 11:** 6

recovery area

Ch. 3: 20; **Ch. 6:** 5-6; **Ch. 10:** 4

roadside

Ch. 2: 1, 7; **Ch. 3:** 1, 20-25, 27, 28, 34, 44, 45, 47, 48, 53, 54; **Ch. 4:** 1-4, 6-12;
Ch. 6: 2, 6; **Ch. 7:** 5, 6; **Ch. 8:** 2, 3, 6; **Ch. 9:** 2; **Ch. 10:** 4; **Ch. 14:** 7

roadside canals

Ch. 4: 4

roadway

Ch. 1: 5; **Ch. 2:** 6; **Ch. 3:** 1-7, 9-12, 14, 18-25, 27, 28, 33, 35, 37-41, 43-45, 47, 50,
51, 54, 55; **Ch. 4:** 1, 3-7, 9, 10, 12; **Ch. 5:** 1-4; **Ch. 6:** 1-6; **Ch. 7:** 3-7; **Ch. 8:** 1-6;
Ch. 9: 1, 2, 4; **Ch. 10:** 4; **Ch. 11:** 2, 4, 5; **Ch. 12:** 1, 2, 5; **Ch. 13:** 2

shoulders

Ch. 3: 16-18, 20, 43, 50, 54; **Ch. 4:** 1, 2, 5, 7; **Ch. 5:** 3-5; **Ch. 8:** 2; **Ch. 9:** 1-4

side slopes

Ch. 3: 22, 23; **Ch. 4:** 3, 6

sidewalks

Ch. 2: 5, 7; **Ch. 3:** 18, 27, 48, 49, 55; **Ch. 8:** 3, 5; **Ch. 13:** 2

sight distance

Ch. 2: 1, 6, 7; **Ch. 3:** 1, 4, 6-9, 14, 15, 25, 26, 28, 34-39, 43, 46, 50, 53; **Ch. 4:** 2;
Ch. 6: 1, 3, 6; **Ch. 7:** 2-4, 6, 7; **Ch. 8:** 5-7; **Ch. 9:** 5; **Ch. 10:** 4; **Ch. 11:** 3;
Ch. 14: 5, 9

signs

Ch. 3: 5, 26, 33-37, 47, 53; **Ch. 4:** 6, 7; **Ch. 6:** 6; **Ch. 7:** 2, 3, 5, 6; **Ch. 8:** 5

skid resistance

Ch. 5: 1-4; **Ch. 7:** 7

slopes

Ch. 3: 18, 21-23, 26, 39, 47, 49; **Ch. 4:** 2, 3, 5, 6; **Ch. 5:** 2-6; **Ch. 14:** 4

speed

Ch. 1: 1, 4, 6; **Ch. 2:** 2 - 4; **Ch. 3:** 3 - 5, 7, 10, 11, 13-15, 18 - 20, 30, 32, 35 - 37,
39-42, 47, 51; **Ch. 4:** 6-8, 12; **Ch. 6:** 3; **Ch. 7:** 2; **Ch. 9:** 6; **Ch. 13:** 3; **Ch. 14:** 4, 9

stopping sight distance

Ch. 3: 7, 14, 34-37, 43; **Ch. 7:** 2; **Ch. 8:** 6; **Ch. 14:** 5, 9

structures

Ch. 3: 7, 9, 22, 25, 27, 28, 36, 47, 54; **Ch. 4:** 6, 7; **Ch. 5:** 1-4; **Ch. 6:** 6; **Ch. 7:** 3;
Ch. 9: 6; **Ch. 10:** 4; **Ch. 11:** 3; **Ch. 12:** 2

superelevation

Ch. 3: 10-13, 16, 38, 42, 45; **Ch. 7:** 4, 5; **Ch. 14:** 4, 9

terminals

Ch. 3: 40, 41

traffic

Ch. 1: 1-8; **Ch. 2:** 2-5; **Ch. 3:** 1-6, 8, 11-13, 15-21, 23, 24, 26-30, 32-41, 43, 45, 46,
48, 50-52, 54, 55; **Ch. 4:** 3, 5, 7; **Ch. 5:** 3; **Ch. 6:** 1, 3, 4, 6; **Ch. 7:** 1, 2, 5-7; **Ch. 8:**
1-6; **Ch. 9:** 1, 2, 4, 5; **Ch. 10:** 1-5; **Ch. 11:** 1-6; **Ch. 12:** 6; **Ch. 13:** 1, 3; **Ch. 14:** 6

traffic control

Ch. 1: 7, 8; **Ch. 2:** 3; **Ch. 3:** 1, 4, 28, 45, 50, 52, 54; **Ch. 6:** 4, 6; **Ch. 7:** 1, 2, 6, 7;
Ch. 8: 5; **Ch. 10:** 3, 4; **Ch. 11:** 1, 2, 4

traffic control devices

Ch. 1: 8; **Ch. 3:** 1, 4, 28, 45, 52, 54; **Ch. 6:** 4, 6; **Ch. 7:** 1, 2, 6; **Ch. 8:** 5; **Ch. 10:** 3,
4; **Ch. 11:** 2

transit shelters

Ch. 3: 25, 51

transitions

Ch. 3: 10, 12, 43, 49; **Ch. 4:** 10

traveled way

Ch. 2: 6; **Ch. 3:** 22, 47, 53; **Ch. 4:** 1, 2, 6

trucks

Ch. 1: 2; **Ch. 3:** 6, 12, 13; **Ch. 9:** 2; **Ch. 13:** 1

turning lanes

Ch. 3: 39

turning roadways

Ch. 3: 12, 35-37, 42-44, 46

utilities

Ch. 2: 5; **Ch. 4:** 2, 7; **Ch. 8:** 2

vegetation

Ch. 3: 6, 36, 53

vehicles

Ch. 1: 2, 5, 10; **Ch. 3:** 2, 4-6, 12, 13, 16, 18, 19, 21-24, 28, 30, 35-47, 51, 53; **Ch. 4:**
1, 2, 4, 7-9; **Ch. 5:** 1, 3; **Ch. 6:** 5; **Ch. 7:** 2, 4, 6; **Ch. 8:** 3; **Ch. 9:** 2-6; **Ch. 11:** 3, 5;
Ch. 13: 1, 3

vertical clearances

Ch. 3: 6

vertical curves

Ch. 3: 13, 14, 33, 43; **Ch. 4:** 2; **Ch. 7:** 4

volume

Ch. 1: 1, 4-6; **Ch. 3:** 2, 5, 15, 17-20, 24, 25, 30, 32, 41, 48; **Ch. 6:** 3; **Ch. 7:** 5;
Ch. 8: 4; **Ch. 9:** 3; **Ch. 11:** 4

warrants

Ch. 6: 2

widening

Ch. 2: 6; **Ch. 3:** 6, 12, 51, 54

width

Ch. 2: 4; **Ch. 3:** 2, 6, 11, 12, 15-25, 27, 38, 39, 42-45, 48, 49; **Ch. 4:** 3, 4, 7-9;
Ch. 5: 3; **Ch. 6:** 5; **Ch. 7:** 3-5, 7; **Ch. 8:** 2; **Ch. 9:** 1-3, 5, 6; **Ch. 13:** 2

work site safety

Ch. 1: 8; **Ch. 10:** 3; **Ch. 11:** 1-4, 6; **Ch. 12:** 1, 6