

AGENDA (Final)

FLORIDA GREENBOOK ADVISORY COMMITTEE MEETING

Thursday, February 16, 2017, 8:30 AM – 5:00 PM

Friday, February 17, 2017, 8:30 AM – 11:30 PM

Florida's Turnpike Orlando Headquarters, Auditorium A
Turkey Lake Service Plaza, Milepost 263
Ocoee, FL 34761

Below is the Go-To-Meeting information if you are not able to attend in person.

Please join my meeting from your computer, tablet or smartphone.

<https://global.gotomeeting.com/join/444507949>

You can also dial in using your phone.

United States: +1 (850) 414-3102

Access Code: 444-507-949

Audio PIN: Shown after joining the meeting

Thursday, February 16, 2017

8:30 – 9:15 Introductions and General Information

- Welcome and Introductions (Michael Shepard)
- Handouts and Green Ring Binders
- Committee and Associate Member Changes (Mary Anne Koos)
- April 2016 Meeting Minutes & Approval (Mary Anne Koos)
- Contact Information, Subcommittee Assignments, Chapter Chair Opportunities (Mary Anne Koos)

9:15 – 9:30 Rulemaking and Sunshine Law

- Rulemaking Status of 2016 Florida Greenbook (Susan Schwartz)
- Sunshine Law (Jason Watts)

9:30 – 10:00 Presentation of Proposed Revisions for 2018 Greenbook

- Introduction (Mary Anne Koos)
- Chapter 14 – Design Exceptions and Variations (Richard Moss, Mary Anne Koos)

10:00 – 10:15 *Morning Break*

10:15 – 12:00 Presentation of Proposed Revisions for 2018 Greenbook

- Chapter 17 – Bridges and Other Structures (Keith Bryant, Mary Anne Koos)
- Chapter 8 – Pedestrian Facilities (Annette Brennan, Mary Anne Koos)
- Chapter 3 – Geometric Design (Mary Anne Koos)
- Chapter 4 – Roadside Design (Charles Ramdatt, Mary Anne Koos)

12:00 – 1:30 *Lunch*

1:30 – 2:00 Greenbook Training

- LAP Training Summary (Mary Anne Koos)
- T2 Center, UF (Maria Cahill)

2:00 – 2:45 Subcommittee Meetings for Final Drafting of Proposed 2018 Revisions

- Introduction, Chapter 3, Chapter 4 – Geometric Design (Michael Shepard, Mary Anne Koos, Auditorium)
- Chapter 8 – Pedestrian Facilities (Annette Brennan, Gabe Matthews, Auditorium)
- Chapter 14 – Design Exceptions and Variations (Richard Moss, Mary Jane Hayden, Auditorium)
- Chapter 17 – Bridges and Other Structures (Keith Bryant, Jeremy Fletcher, Room 2130)

2:45 – 3:00 *Afternoon Break*

3:00 – 5:00 Chapter Report and Vote on 2018 Chapter Revisions

- Introduction and Chapters 3, 4, 8, 14, 17 (Chapter Chairs, Mary Anne Koos)

5:00 *Adjourn*

Friday, February 17, 2017

8:00 – 8:30 Future Greenbook Revisions

- Parking Lot Topics Discussion (Michael Shepard)
- Goals and Selection of Chapters for Future Work (Michael Shepard)
- Subcommittees, Chair Opportunities (Mary Anne Koos)
- CE Credits for Professional Engineers (Mark Massaro, Mary Anne Koos)

8:30 – 9:00 Presentation from FDOT Safety Office

- Lane Departure Implementation Plan, Engineering Coalition, and Florida Strategic Highway Safety Plan (Joe Santos)

9:00 – 9:15 Group Photo

9:15 – 9:30 *Break*

9:30 – 10:30 Discussion from FDOT Traffic Operations Office

- Manual for Speed Zoning for Highways, Roads and Greenbook Training – School Zones (Alan El-Urfali)

10:30 - 11:15 Breakout Sessions for Future Greenbook Revisions

- Chapter ___ Training_____ (Auditorium A, Mary Anne)
- Chapter ___ Complete Streets_____ (Auditorium A, Mary Jane)
- Chapter ___ Lighting_____ (Room 2130, Jeremy)
- Chapter _____ (Room 2131, Paul)

11:15 – 11:45 Chapter Chair Reports for Future Greenbook Revisions and Discussion

11:45 – 12:00 Closing Remarks (Michael Shepard)

12:00 *Adjourn*

Note – There is no registration fee to attend and no meals are provided.

Minutes (Final)

FLORIDA GREENBOOK ADVISORY COMMITTEE MEETING

Thursday, February 16, 2017, 8:30 AM – 5:00 PM

Friday, February 17, 2017, 8:00 AM – 12:00 PM

Florida's Turnpike, Orlando Headquarters, Auditorium A
Turkey Lake Service Plaza, Milepost 263
Ocoee, FL 34761

Thursday, February 16, 2017

Attendance

The following members, associate members, Department staff, technical advisors and public were in attendance, either in-person or remotely via Go-To-Meeting.

- **Members**

Bernie Masing, Shane Parker, Andy Tilton, Alexandria Davis-Shaw, Kathy Thomas, Kenneth Dudley, Gene Howerton; John Veilleux, Rodney Chamberlain, Rick Hall, Keith Bryant, Steve Braun, Robert Behar, Richard Szpyrka, George Webb, Annette Brennan, Gail Woods, Billy Hattaway, Richard Baier, Daniel Iglesias, Gaspar Miranda, Juvenal Santana, Richard Moss, Richard Diaz, Milton Martinez, and Margaret Smith.

- **Associate Members**

Mark Massaro, Charles Ramdatt, Allen Schrupf, and Ramon Gavarrete.

- **FDOT Staff, Technical Advisors and Public**

Tim Lattner, Michael Shepard, Mary Anne Koos, Mary Jane Hayden, Paul Hiers, Alan El-Urfali, Gail Holley, Jeremy Fletcher, Mariano Amicarelli, Gabe Matthews, Amy Neidringhaus, Joe Santos, Susan Schwartz, Jason Watts, Andre Pavlov, DeWayne Carver, Mary O'Brien, Derwood Sheppard, Leslie Wetherell Jim Mills, Cathy Evangelo, Natrevia Mitchell, Abdul Azim, Frank Yokiell, Kenneth Leeming, Jeremy Crowe, Christine Lofye, Hazem El-Assar, Maria Cahill, and Duane Brautigam.

Introductions and General Information

- **Welcome and Introductions (Michael Shepard & Mary Anne Koos)**

Michael Shepard, Chair, of the Florida Greenbook Committee welcomed members and the public to the 2017 Florida Greenbook Committee meeting. –Mary Anne Koos summarized changes in membership for the Committee due to retirement or new positions for former members and new members were introduced. These include Shane Parker, Hendry County

(rural local government for District 1), Alexandra Davis-Shaw, City of Sarasota (urban local government for District 1), Rodney Chamberlain, FDOT District 3, Steve Braun, FDOT District 4, Richard Szpyrka, (rural local government for District 4), Billy Hattaway, City of Orlando (urban local government for District 5), and Daniel Iglesias, FDOT District 6.

Steven Neff (City of Cape Coral), Chris Mora (Indian River County), and Charles Ramdatt (City of Orlando) have retired from public service. Charles Ramdatt will continue serving as an Associate Member on the Greenbook Committee. Jared Perdue, Howard Webb, and Chris Tavella have new positions with FDOT and no longer serve as FDOT's District Design Engineer representatives on the Committee.

- **Review Contact Information (Mary Anne Koos)**

The Committee Membership list was circulated for everyone to update their contact information.

- **Update Subcommittee Assignments (Mary Anne Koos)**

The list of current chairs for the chapter subcommittees was reviewed and a signup sheet was circulated so that members could update their subcommittee membership preferences.

- **Review April 2016 Meeting Minutes (Mary Anne Koos)**

The draft minutes were distributed and reviewed. Andy Tilton moved to approve the minutes and then seconded by Gail Woods, approved unanimously.

- **Rulemaking (Mary Anne Koos, Susan Schwartz)**

The 2016 Florida Greenbook (Draft) has completed the Notice of Rule Development process and received no comments. It is ready to move to the Notice of Proposed Rule. Once that is approved, it will be submitted to the Legislature's Joint Administrative Procedures Committee (JAPC) for review. A Notice of Change and then a Notice of Adoption will be published, and then the 2016 Greenbook will be effective.

The draft Greenbook was updated to include current editions of the [*AASHTO Load and Resistance Factor Design \(LRFD\) Bridge Design Specifications, 7th Edition \(2014\)*](#) with *Interim Revisions (2015 and 2016)*, *Structures Manual, Volume 1 – Structures Design Guidelines, 2017 (SDG)*, and *LRFD Specifications for Structural Supports for Highway Signs, Luminaires and Traffic Signals, 1st Edition (2015) with 2017 Interims*, The revised draft is published on FDOT's Florida Greenbook web page.

- **Sunshine Law (Jason Watts)**

Jason Watts reminded the committee that we are required to follow Florida's Sunshine Law requirements. All discussion between voting members must be conducted in a public meeting. He reminded the committee that they cannot meet or discuss business through an intermediary.

Presentation of Proposed Revisions for 2018 Florida Greenbook

All revisions shown are anticipated for publication in the 2018 Greenbook Edition. The meeting package includes the revisions that will be discussed today and can be added to the ring binders as an update to the chapters. Ms. Koos reviewed the color-coding of the text for the group. Green-highlighted text has already been approved by the Committee in previous meetings. Yellow highlights are notes that will be deleted in the final format or are areas that need follow up discussion.

- **Introduction (Mary Anne Koos)**

Mary Anne Koos presented the proposed changes to the chapter, as shown in the draft, dated February 10, 2017. Definitions for border area, lateral offset, reconstruction, and shared use path or multi-use trail. The definition for horizontal clearance was deleted. The following revisions were suggested for further discussion in the chapter breakout session:

- Update the name of the FDOT Statistics Office to a generic reference of “the Department.”
- Change “streets and highways” to “transportation facilities” (on pg. ii)
- Revise definition of Shared Use Path or Multi-Use Trail. Should an allowance for motorized vehicles (e.g., golf carts) be included? Options are to add “special designs are required when motorized vehicles or scooters will use the path” and add the word “easement.”

- **Chapter 14 – Design Exceptions and Variations (Richard Moss, Mary Anne Koos)**

Richard Moss and Mary Anne Koos presented the proposed changes to the chapter, as shown in the draft, dated February 10, 2017. Major revisions included reducing the number of controlling design elements from 13 to 10 (high speed) and 2 (low speed), based upon the new FHWA guidance. Clarified that when design elements other than the controlling criteria do not meet Greenbook criteria, the “Responsible Professional Engineer” must document the deviation.

The process and documentation for justifying, coordinating, and approving Design Exceptions and Variations was clarified. Exhibit 14 - A Sample Request Letter for Design Exception or Variation was revised. The following revisions were suggested for further discussion in the chapter breakout session:

- How to address approval/concurrence/acknowledgement of Exceptions/Variations in small municipalities that don't employ P.E.s and can't afford to hire P.E.s to review these items. There were three options:
- One option is to change Section G to “designated Professional Engineer or Administrator representative of the municipality...”
- A second is that the county commission/board provide the approval/concurrence for small municipalities that don't employ P.E.s.
- A third is that any design variation be reviewed and approved by the “responsible authority”.
- Determine if there should be a provision for the Design Exception to be reviewed at a higher level (i.e., another P.E.)?

- **Chapter 17 – Bridges and Other Structures (Keith Bryant, Mary Anne Koos)**

Keith Bryant and Mary Anne Koos presented the changes that were made as part of updating the reference documents for the 2016 rulemaking draft of the Greenbook. Then the proposed changes for the 2018 Greenbook, as shown in the draft dated February 8, 2017 were presented.

The revisions for the 2016 edition included updating the references for the AASHTO Load and Resistance Factor Design (LRFD) Bridge Design Specifications, 7th Edition (2014) and the AASHTO LRFD Specifications for Structural Supports for Highway Signs, Luminaires, and Traffic Signals, 1st Edition (2015) with 2017 Interims. The Committee asked that Section C.5 Retaining and Noise Walls follow SDG, Section 3.16 be revised from a “shall” to a “should” condition.

Major revisions for the 2018 Greenbook include revising Section C.4.b Vessel Impacts to Navigation Aids and Vessel Collision, and adding requirements for bridge fender systems on bridges over USCG designated navigable waterways. Section C.5 was further revised from a “shall” to a “should” condition regarding the use of crash tested systems.

Keith Bryant asked whether the subcommittee for Chapter 6 – Lighting would like to discuss adding criteria for aesthetic lighting for bridges. Bay County has seen an increased interest in aesthetic lighting for bridges?

Since there was agreement with the revisions that had been presented, Andy Tilton moved to accept the revised Chapter, seconded by Keith Bryant. The Committee voted unanimously to accept the changes.

- **Chapter 8 – Pedestrian Facilities (Annette Brennan, Mary Anne Koos)**

Annette Brennan and Mary Anne Koos presented the proposed changes for the 2018 Greenbook, as shown in the draft dated February 15, 2017. Section G.2 Curb Ramps and Blended Transitions was revised to emphasize the need for continuous accessible pedestrian routes and include criteria for blended transitions. Language was added to clarify when curb ramps are needed, that ramps should align with crosswalks and requirements to relocate or adjust pull boxes and manholes within the sidewalk.

Language was added to clarify that when following the profile grade of a roadway, ramp slopes do not need to exceed 15 feet in length. When constrained by existing conditions, curb ramp slopes may be increased to 1:10 with a maximum rise of 6 inches.

In Section G.3 Detectable Warnings, criteria was added for when detectable warnings are required on sidewalks and shared use paths and to consider the compatibility of walking surface and detectable warning products.

Guidance was added from Chapter 10 stating that existing driveways and turnouts should be evaluated for compliance with ADA requirements, and that nonconforming driveways do not need to be adjusted if not feasible within the project's scope.

Section G.1.b was revised to emphasize the need to request interim approval from FHWA if Rectangular Rapid Flashing Beacons (RRFB) will be used.

The following revisions were suggested for further discussion in the chapter breakout session:

- Determine needs for further guidance on the design of sidewalk at driveways and turnouts.
- Whether clarification is needed for the design of blended transitions at median refuge islands.
- Revise definition of Shared Use Path or Multi-Use Trail. Should an allowance for motorized vehicles (e.g., golf carts) be included? Options are to add “special designs are required when motorized vehicles or scooters will use the path” and add the word “easement.”
- Develop a revised definition for shared use paths and multi-use trails.

- **Chapter 4 – Roadside Design (Charles Ramdatt, Mary Anne)**

Charles Ramdatt and Mary Anne Koos presented the proposed changes for the 2018 Greenbook, as shown in the draft dated February 13, 2017. The chapter has been rewritten to provide an environment that will reduce the likelihood and consequences of crashes by vehicles that leave the traveled way. Information was added on the preferences for removing or shielding hazards and crash test data from the AASHTO Roadside Design Guide.

New sections have been added that address:

- roadside topography and drainage features,
- roadside safety features and crash test criteria,
- signs, signals, lighting supports, utility poles, trees and similar roadside features,
- barriers, end treatments and crash cushions,
- bridge rails, and
- updated references.

The revisions included the movement of criteria from Chapter 3 – Geometric Design to Chapter 4, including criteria addressing roadside slopes, clear zones, and lateral offsets. Table 4 – 1 Minimum Width of Clear Zone (feet) provides dimensions for clear zones for new construction or reconstruction of roadways. Table 4 – 2 Lateral Offset (feet) includes criteria for lateral offsets from above ground fixed objects, drop-off hazards, and water bodies.

The minimum offsets for canal hazards on flush shoulder and curbed roadways are found in Figure 4 – 6 Minimum Offsets for Canal Hazards Rural and Flush Shoulder Roadways and Figure 4 – 7 Minimum Offsets for Canal Hazards Urban Curb or Curb and Gutter. The following topics were suggested for further discussion in the chapter breakout session:

- Clarification of Figure 4 – 1 Clear Zone Plan View to better define where measurements are based on and also when to consider end treatments for opposing traffic.
- If there needs to be further guidance on the design of sidewalks at driveways and turnouts.
- Whether clarification is needed for the design of blended transitions at median refuge islands.

**** Lunch Break 12:15 – 1:30 PM ****

- **Chapter 3 – Geometric Design (Mary Anne Koos)**

Mary Anne Koos presented the proposed changes for the 2018 Greenbook, as shown in the draft dated February 14, 2017. The chapter has been revised to remove the topics now covered in Chapter 4 – Roadside Design. These include Section C.7.g (clear zone, lateral offset, roadside slopes and criteria for guardrail). References to Chapter 4 were added regarding cross section elements and curbs.

There were no further comments on the changes. The Subcommittees for Chapters 3 and 4 will meet together to develop the final language for Chapters 3 and 4.

LTAP Center Training (Maria Cahill, University of Florida)

Maria Cahill gave an overview of the University of Florida's LTAP Center and their past experience in providing training on the Florida Greenbook. Following is a summary of the Committee's questions on future training for the Greenbook:

- Who is the target audience? Local engineers, planners, technicians.
- Will there be AICP credits? T2 is working to become an approved AICP provider
- Will there be PE credits? Yes.
- Great idea for young engineers. His City is working to get people to be familiar with the Florida Greenbook.
- Would send staff and would prefer hands-on training.
- Thinks it's necessary; would like concurrence on the top 6 to 10 topics of interest; would like to develop a YouTube video on common issues.
- Beneficial for new engineers; young staff, including maintenance staff; can FDOT develop a case study for how Greenbook criteria has been incorporated into plans? Field review as part of the class?
- Training young staff would be beneficial; an in-person class is preferable to webinar.
- Good idea, especially with the FDOT Design Manual and Complete Streets effort; suggested the Mayors' Institute for training (each city brings an urban design issue to the training to workshop.
- Great idea; likes the idea of bringing a practical project to the class as a workshop
- Would like to see live training in each district.
- Case studies and lessons learned would be good additions.

Subcommittee Meetings for Final Drafting of Proposed 2018 Revisions

The Committee broke out into chapter subcommittee groups to discuss in more detail the revisions proposed in the meeting package and to follow up on the comments from the morning's presentations. The following subcommittees met:

- Chapter 3 – Geometric Design with Chapter 4 – Roadside Design
- Introduction and Chapter 8 – Pedestrian Facilities
- Chapter 14 – Design Exceptions and Variations
- Chapter 17 – Bridges and Other Structures

Chapter Reports and Approval of 2018 Greenbook Revisions

- **Introduction (Annette Brennan)**

Ms. Brennan presented a proposed revision to the draft Introduction following the Pedestrian Facilities subcommittee breakout meeting. The following revision was recommended:

- Shared Use Path definition revised to read “A facility with a firm, stable, slip-resistant surface physically separated from motorized vehicular traffic by an open space or barrier with minimal cross flow by motor vehicles. Users may include pedestrians, bicyclists, skaters, and others. Special design is needed when travelers use vehicles such as golf carts.”

Moved by Richard Baier to approve this change to the draft Introduction, along with revisions made earlier in the day; seconded by Richard Diaz. Unanimously approved, none opposed.

- **Chapter 4 – Roadside Design (Charles Ramdatt)**

Mr. Ramdatt presented an overview of the proposed revisions to the draft following the Roadside Design subcommittee breakout meeting. The following revisions were recommended:

- Section A Introduction – deleted the last sentence of the first paragraph of this chapter which reads “Design of roadside should be based upon reducing the consequences to errant vehicles and their occupants.” Also deleted the following bullet “Protection of pedestrians, workers, or other persons subjected to the hazard of errant vehicles.”
- Section B.2.c Canals and Water Bodies – revised second bullet (flush shoulder roadways) to match the figure (45 mph or less). Revised the third bullet to say “curbed roadways...”

- Section D.8.c Mailbox Supports – revised the criteria from “shall” to “should” for the offset criteria for the roadside face of the box on flush shoulder and curbed roadways on page 27. Delete the bullet “Mailbox supports should not be set in concrete unless ...” Revise the minimum spacing between the centers of support posts from “shall” to “should” in the last bullet.
- Section E.6.f.1 Barrier Offsets – revised Figure 4 – 8 Location of Guardrail shows the optional sidewalk at the back of curb, with a dimension of 4’ to 12’ offset for the guardrail. To minimize confusion that the 4’ dimension may imply that sidewalks located at the back of curb that are less than 6’ wide are acceptable. Update the figure to reference Chapters 8 & 9 for lateral offset requirements for sidewalks and shared use paths.

Moved by Richard Diaz to approve these revisions to the draft Chapter 4 – Roadside Design, along with revisions made earlier in the day; seconded by Richard Baier. Unanimously approved, none opposed.

- **Chapter 3 – Geometric Design (Charles Ramdatt)**

Mr. Ramdatt presented an overview of the proposed revisions to the draft Geometric Design chapter following the subcommittee breakout meeting. The following revisions were recommended:

- Section C.7.g Roadside Clear Zone - revised the title to match Chapter 4 (which now is “Roadside Slopes, Clear Zone, and Lateral Offset”) for consistency.
- Section C.7.h Curbs – deleted the sentence “Sloping curbs are used along the outside edge of the roadway to discourage vehicles from leaving the roadway.”
- Section C.8 Access Control - added a reference to F.A.C. 14-97 and the Departments Driveway Information Guide and Median Handbook for further information on designing for access management.
- Section C.8.b.1 Location of Access Points – revised the third sentence to read “Driveways should not be placed near the influence zone of intersections or other points...”

It was also suggested that the guidance for roundabout design be worked on in the upcoming year. Moved by Gaspar Miranda to approve these revisions to the draft Chapter 3 – Geometric Design, seconded by Annette Brennan. Unanimously approved, none opposed.

- **Chapter 14 – Design Exceptions and Variations (Richard Moss)**

Mr. Moss presented an overview of the proposed revisions to the draft Design Exceptions and Variations chapter following the subcommittee breakout meeting. The following revisions were recommended:

- Sections C, G and Exhibit A – revised to identify the responsible party for the local government to be known as the “Maintaining Authority’s Professional Engineer or Designee.

Moved by Bernie Masing to approve these revisions to the draft Chapter 14 – Design Exceptions and Variations, seconded by Keith Bryant. Unanimously approved, none opposed.

- **Chapter 8 – Pedestrian Facilities (Annette Brennan)**

Ms. Brennan presented an overview of the proposed revisions to the draft Pedestrian Facilities chapter following the subcommittee breakout meeting. The following revisions were recommended:

- Sections B.1 Sidewalks – move the sentences “Evaluate existing driveways and turnouts for compliance with ADA requirements. Nonconforming driveways are not required to be upgraded if it is not feasible within the scope of the project.” To this section from Section G.2.
- Section B.2 Shared Use Paths – revised “road” to “roadway”.
- Figure 8 – 2 Sidewalk with Guardrail – harmonize with revisions to same figure in Chapter 4 regarding minimum sidewalk widths.
- Section G.3 Detectable Warnings – updated the dimension of detectable warnings to say “2 feet in length” instead of “deep.”
- Section G.5 Sight Distance – deleted the phrase “for at least 15 feet from the outside travel lane”.
- Section G.6 Rail Crossings – struck “surface commuter rail, conventional” from first sentence since passenger rail covers these and added “streetcar rail”.

Moved by Juvenal Santana to approve these revisions to the draft Chapter 8 – Pedestrian Facilities, seconded by Billy Hattaway. Unanimously approved, none opposed.

Continuing Education Credits

The Florida Board of Professional Engineers has agreed to provide 4 credits for our 2017 Greenbook meeting. They are revisiting the requirements for their continuing education program; so, it’s uncertain if our 2018 meeting will qualify for credits.

The Greenbook Committee adjourned for the day at 5:00 PM.

Friday, February 17, 2017

Future Greenbook Revisions (Mary Anne Koos)

The Committee discussed what topics they should consider for future improvements to the Greenbook for a 2018 edition. The following were suggested:

- **Chapter 3 – Geometric Design (Andres Garganta)**

While much progress has been made in updating the Florida Greenbook to be consistent with AASHTO's 2011 Greenbook, some work still needs to be done on updating figures and tables. The Committee also asked that additional information on the design of roundabouts be included.

- **Chapter 6 – Lighting (Bernie Masing)**

The subcommittees agreed to look at developing guidance for decorative lighting for bridges and also the illumination values of LED versus high pressure sodium. It was suggested that FDOT's Traffic Operations and Roadway Design Offices assist with revisions, along with support from Palm Beach County.

- **Chapter 18 – Signing and Marking (Gail Woods)**

The subcommittee agreed to continue to work with FDOT's Traffic Operations Office on the proposed revisions to the Department's Speed Zoning Manual and the signing and marking of school zones. The Committee asked to be informed when the Speed Zoning Manual would be available for public comment.

- **Chapter 19 – Traditional Neighborhood Design (Rick Hall)**

The Committee would like to work on developing more of a "Complete Streets" approach in the Greenbook. Michael Shepard provided a brief description of the Department's efforts with the FDOT Design Manual and Complete Streets Handbook. It was suggested that the Committee identify which chapters will likely be impacted by Complete Streets and have those chapter chairs coordinate with each other to update as appropriate. Documents from the National Association of Realtors: Walkable Communities will be distributed to members to begin this review.

- **Chapter 20 – Drainage (George Webb)**

The Department's Drainage Manual and Handbooks have recently been revised and consolidated. Tables for preferred inlet types that were in the Handbooks are now in the Manual. The drainage chapter should be revised to include these updates and also changes that have occurred in how stormwater can be managed and treated.

Training (Mary Anne Koos)

With so many changes to the 2016 Greenbook, there is a need for training. The preferences of the committee will be discussed later in a breakout session.

Strategic Highway Safety Plan (Joe Santos)

Mr. Santos gave an overview of FDOT's 2016 Strategic Highway Safety Plan which can be found at the Safety office web page:

<http://www.fdot.gov/safety/SHSP2016/SHSP-2012.shtm>

The update of the plan included an analysis of crash data and trends affecting fatalities and serious injuries and involved coordination with safety coalitions, MPOs, and other regional and local partners.

Group Photo

A group photo was taken of all Committee members, technical advisors, and support staff.

Speed Zoning Manual – School Zones (Alan El-Urfali)

Mr. El-Urfali gave an overview of FDOT's Traffic Operations Office's efforts in revising the Speed Zoning Manual to include criteria for the signing and marking of school zones. The Committee discussed the requirements for documenting existing school zones, the process for reimbursement and which items would be eligible. Additionally, discussed was how existing pavement markings should be addressed, and the timing of the rulemaking process.

Breakout Sessions for Future Greenbook Revisions

The Committee broke out into three smaller groups (Training, Lighting, and Complete Streets) to develop a work plan for future Chapter revisions.

Chapter Chair Reports for Future Greenbook Revisions and Discussion

In addition to the comments earlier in the morning regarding future efforts, below is a summary of the discussion from the breakout groups:

- Training (Mary Anne Koos)
 - Create a survey in Survey Monkey to determine the level of interest and the type of training desired. Include members of the Florida Association of County Engineers (FACERS) in the survey.

- Committee members should identify 3 to 4 issues that they frequently seek guidance on in the Greenbook as a starting point for training development.
- **Lighting (Bernie Masing)**
 - Add a subsection for aesthetic lighting to the chapter. Jeremy Fletcher agreed to assist with drafting language.
 - Review the LED Illumination Lighting Table and whether values should be adjusted for LED versus high-pressure sodium (HPS) lamps. Allan Shrumpf and Charles Ramdatt agreed to assist since they have photometric experts on their staff.
- **Complete Streets (Rick Hall)**
 - Beginning July 2017, make a collaborative effort between subcommittee chairs to assess the updates needed for Complete Streets. Eleven chapters are potentially impacted: 1, 2, 3, 4, 8, 9, 10, 13, 15, 16, and 19. Start by updating Chapter 19 (first step would be updating the name of the chapter to Complete Streets). Secondly, determine what can be incorporated into the other chapters, and update those at a later time. Rick Hall will be the lead on this effort.
 - Update the Traditional Neighborhood Design (TND) Handbook, based on FDOT's Complete Streets Handbook.

Chapter Chair Opportunities (Mary Anne Koos)

Due to retirements and changes in positions at FDOT, there are several vacancies in the Chapter Chair positions. Members were asked to consider whether they would like to serve as chair for those chapters. These include Chapter 3 – Geometric Design, Chapter 4 – Roadside Design, Chapter 13 – Public Transit, and Chapter 15 – Traffic Calming.

Robert Behar agreed to serve as chair for Roadside Design, and suggested Andre Garganta would be an excellent choice for the Geometric Design chapter due to his extensive knowledge of roadway criteria. Milton Martinez agreed to serve as chair for the Transit chapter and Billy Hattaway agreed to serve as chair for the Traffic Calming chapter. (*Mr. Garganta, who was not at the meeting, later conformed he would be willing to serve as chair.*)

Tentative 2018 Florida Greenbook Meeting (Mary Anne Koos)

The logistics for next year's meeting was discussed. They preferred the meeting be scheduled for a Thursday and Friday, and that the District Design Engineer meeting be held the Wednesday before. The Committee prefers to keep the meeting in the Orlando area. Lynx has facilities that are available at no cost in downtown Orlando, and the committee is open to meeting there. However, they prefer to meet at the Florida Turnpike facilities.

Closing Remarks (Mary Anne Koos)

Ms. Koos thanked the group for their continued service on the Greenbook Committee and their work in developing transportation systems that serve all users and improve safety.

The Greenbook Committee adjourned at 12:00 PM.

FLORIDA GREENBOOK ADVISORY COMMITTEE MEMBERS 2016

DISTRICT 1

Bernie Masing, P.E.
District Design Engineer
FDOT - District 1
801 North Broadway Street
Bartow, Florida 33830-1249
(863) 519-2543
bernie.masing@dot.state.fl.us

Shane Parker, P.E.,
Public Works Director
Hendry County
P.O. Box 1607
La Belle, FL 33975
(863) 675-5222
sparker@hendryfla.net

Andy Tilton, P.E.
Water Resource Director
Johnson Engineering, Inc.
251 West Hickpochee Avenue
LaBelle, Florida 33935
(863) 612-0594
atilton@johnsoneng.com

Alexandrea Davis-Shaw, P.E.
City Engineer
City of Sarasota
1565 1st Street, Sarasota, FL 34236
(941) 365-2200 x 4181
Alexandrea.DavisShaw@sarasotagov.com

DISTRICT 2

Kathryn D. Thomas, P.E.
District Design Engineer
FDOT - District 2
1109 South Marion Avenue
Lake City, Florida 32025-5814
(386) 961-7533
kathy.thomas@dot.state.fl.us

Kenneth Dudley, P.E.
County Engineer
Taylor County
Board of County Commissioners
201 East Green Street
Perry, Florida 32347
(850) 838-3500x104
county.engineer@taylorcountygov.com

Gene Howerton, P.E.
Vice President
Arcadis U.S., Inc.
1650 Prudential Drive, Suite 400
Jacksonville, Florida 32207
(904) 721-2991
Gene.Howerton@arcadis-us.com

John Veilleux, P.E.
Supervising Engineer
City of Gainesville Public Works
P.O. Box 490, Mail Station 58
Gainesville, FL 32602
veilleuxj@cityofgainesville.org

DISTRICT 3

Rodney Chamberlain, P.E.
District Design Engineer
FDOT - District 3
Post Office Box 607
Chipley, Florida 32428
(850) 330-1492
rodney.chamberlain@dot.state.fl.us

Rick Hall, P.E.
Hall Planning and Engineering, Inc.
322 Beard Street
Tallahassee, Florida 32303
(850) 222-2277
rickhall@hpe-inc.com

Roger A. Blaylock, P.E.
County Engineer
Santa Rosa County
6051 Old Bagdad Highway, Suite 300
Milton, Florida 32583
(850) 981-7100
RogerB@santarosa.fl.gov

Keith Bryant, P.E., P.T.O.E.
Public Works Director
Bay County
840 West 11th Street, Suite 2400
Panama City, Florida 32401
(850) 248-8302
kbryant@baycountyfl.gov

DISTRICT 4

Steve Braun, P.E.
District Design Engineer
FDOT - District 4
3400 West Commercial Blvd
Ft. Lauderdale, Florida 33309
(954) 777-4439
Steve.braun@dot.state.fl.us

Robert Behar, P.E.
President
R.J. Behar and Company, Inc.
6861 SW 196 Avenue, Suite 302
Pembroke Pines, Florida 33332
(954) 680-7771
bbehar@rjbehar.com

Richard B. Szpyrka
Director of Public Works
1801 27th Street
Vero Beach, FL 32960-3388
(772) 226-1379
rszpyrka@ircgov.com

George T. Webb, P.E.
County Engineer
Palm Beach County
Post Office Box 21229
West Palm Beach, Florida 33416-1229
(561) 355-2006
GWebb@pbcgov.org

DISTRICT 5

Annette Brennan, P.E.
District Design Engineer
FDOT - District 5
719 South Woodland Boulevard
Deland, Florida 32720
(386) 943-5543
annette.brennan@dot.state.fl.us

Gail Woods, P.E.
Transportation Manager
WBQ Design and Engineering, Inc.
201 N. Magnolia Avenue, Suite 200
Orlando, Florida 32801
(407) 839-4300
Gwoods@wbq.com

Billy Hattaway, P.E.
Transportation Department Director
City of Orlando
400 South Orange Avenue
Orlando, Florida 32801
(407) 246-2266
billy.hattaway@cityoforlando.net

Richard Baier, P.E., LEED, AP
Sumter County Assistant County
Administrator and Public Works Director
319 East Anderson Avenue, Suite 111
Bushnell, Florida 33513
(352) 569-6700
richard.baier@sumtercountyfl.gov

DISTRICT 6

Daniel Iglesias, P.E.
District Design Engineer
FDOT - District 6
1000 NW 111th Avenue
Miami, Florida 33172
(305) 470-5103
daniel.iglesias@dot.state.fl.us

Andres Garganta, P.E.
Vice President
WGI
11401 S.W. 40th Street, Suite 455
Miami, Florida 33165
(305) 461-5484x7304
agarganta@csagroup.com

Gaspar Miranda, P.E.
Assistant Director, Highway Engineering
Miami-Dade County
Public Works Department
111 N.W. 1st Street, Suite 1510
Miami, Florida 33128
(305) 375-2130
GXM@miamidade.gov

Juvenal Santana, P.E.
Deputy Director
City of Miami Public Works Department
444 S.W. 2nd Avenue, 8th Floor
Miami, Florida 33130
(305) 416-1218
jsantana@miamigov.com

DISTRICT 7

Richard Moss, P.E.
District Design Engineer
FDOT - District 7
11201 N. McKinley Drive
Tampa, Florida 33612
(813) 975-6030
richard.moss@dot.state.fl.us

Richard Diaz, Jr., P.E.
President
Diaz Pearson & Associates, Inc.
4202 El Prado Blvd.
Tampa, Florida 33629
(813) 258-0444
richard@diazpearson.com

Milton J. Martinez, P.E.
Chief, Transportation Engineer,
Transportation and Stormwater Services
City of Tampa
306 E. Jackson Street, 4E
Tampa, Florida 33602
(813) 274-8998
milton.martinez@tampagov.net

Margaret W. Smith, P.E.
Engineering Services Director/
County Engineer
West Pasco Government Center
87313 Citizens Drive, Suite 321
New Port Richey, FL 34654
(727) 847-2411, ext. 7452
mwsmith@pascocountyfl.net

ASSOCIATE MEMBERS

Ramon D. Gavarrete, P.E.
County Engineer
Alachua County
Board of County Commissioners
5620 NW 120th Lane
Gainesville, Florida 32653
(352) 548-1214
rgavarrete@alchuacounty.us

David F. Kuhlman
Florida Power & Light Company
7200 NW 4th Street
Plantation, Florida 33317
(954) 321-2188
David.F.Kuhlman@fpl.com

Mark V. Massaro, P.E.
Director, Public Works Dept.
Orange County
4200 South John Young Parkway
Orlando, Florida 32839
(407) 836-7970
mark.massaro@ocfl.net

Charles Ramdatt, P.E., P.T.O.E., AICP
City of Orlando
400 South Orange Avenue
Orlando, Florida 32801
(407) 246-3186
Charles.Ramdatt@cityoforlando.net

Faith Alkhatib, P.E.
FACERS Representative
Public Works Director
Flagler County
1769 East Moody Blvd., Building 5
Bunnell, FL 32110
alkhatib@flaglercounty.org

ASSOCIATE MEMBERS (continued)

Allen W. Schrupf, P.E.
Senior Associate
DRMP, Inc.
941 Lake Baldwin Lane
Orlando, Florida 32814
(407) 897-0594
aschrumpf@drmp.com

COMMITTEE STAFF, FDOT

Tim Lattner, P.E.
Director, Office of Design
605 Suwannee St., MS 38
Tallahassee, FL 32399-0450
(850) 414-4175
tim.lattner@dot.state.fl.us

Michael Shepard, P.E., Chairperson
State Roadway Design Engineer
605 Suwannee St., MS 32
Tallahassee, Florida 32399-0450
(850) 414-4283
michael.shepard@dot.state.fl.us

Mary Anne Koos
Special Projects Coordinator
605 Suwannee St., MS 32
Tallahassee, Florida 32399-0450
(850) 414-4321
maryanne.koos@dot.state.fl.us

Paul Hiers, P.E.
Roadway Design Criteria Administrator
605 Suwannee St., MS 32
Tallahassee, Florida 32399-0450
(850) 414-4324
paul.hiers@dot.state.fl.us

Mary Jane Hayden, P.E.
Roadway Design Engineer
605 Suwannee St., MS 32
Tallahassee, Florida 32399-0450
(850) 414-4783
maryjane.hayden@dot.state.fl.us

CHAPTER TECHNICAL ADVISORS

Gabrielle (Gabe) Matthews
Transportation Modeler
605 Suwannee Street, MS 27
Tallahassee, Florida 32399-0450
(850)-414-4803
gabrielle.matthews@dot.state.fl.us

Regina Colson
605 Suwannee Street, MS 28
Tallahassee, Florida 32399-0450
850-414-4807
regina.colson@dot.state.fl.us

Christine Lofye, P.E.
Project Manager
Orange County Public Works Department
Traffic Engineering Division
4200 S. John Young Parkway
Orlando, Florida 32839
christine.lofye@ocfl.net

Gevin McDaniel, P.E.
Roadway Design Standards Administrator
605 Suwannee St., MS 32
Tallahassee, Florida 32399-0450
(850) 414-4284
gevin.mcdaniel@dot.state.fl.us

Derwood Sheppard, P.E.
Design Standards Publication Manager
605 Suwannee St. MS 32
Tallahassee, Florida 32399-0450
850-414-4334
derwood.sheppard@dot.state.fl.us

Chester Henson, P.E.
State Traffic Standards Engineer
605 Suwannee St., MS 32
Tallahassee, Florida 32399-0450
(850) 414-4117
chester.henson@dot.state.fl.us

Frank Kreis, P.E.
District Bituminous Engineer
1074 Highway 90 East
Chipley, Florida 32428
(850) 330-1634
frank.kreis@dot.state.fl.us

Amy Harris, P.E.
Special Projects Manager
Traffic Engineering
2300 North Jog Road, 3rd Floor
West Palm Beach, FL 33411-2745
(561)-684-4138
aharris@pbcgov.org

Ryan "Keith" Slater, P.E.
District Traffic Design Engineer
801 N. Broadway Ave.
Bartow, FL 33831
(863) 519-2498
keith.slater@dot.state.fl.us

Rochelle Garrett, P.E.
District 7 Traffic Design Engineer
11201 N. McKinley Drive
Tampa, FL 33612
(813) 975-6733
rochelle.garrett@dot.state.fl.us

Frank C. Yokiell, AICP
Orange County Public Works Department
Engineering Division
4200 S. John Young Parkway
Orlando, Florida 32839
(407)-836-8073
frank.yokiell@ocfl.net

**CHAPTER TECHNICAL ADVISORS
(continued)**

Luis A. Alván, Esq., P.E.
Senior Engineer
Orange County Public Works Department
Engineering Division
4200 S. John Young Parkway
Orlando, Florida 32839
(407)-836-8030
luis.alvan@ocfl.net

Andre Goins, P.E.
State Rail Operations and Programs
Administrator
605 Suwannee Street, MS-25
Tallahassee, Florida 32399-0450
(850) 414-4620
andre.goins@dot.state.fl.us

George Borchik, P.E.
District Roadway Design Engineer
719 South Woodland Blvd.
Deland, Florida 32720
386-943-5163
george.borchik@dot.state.fl.us

DeWayne Carver, AICP
State Bicycle/Pedestrian Coordinator
605 Suwannee Street MS 32
Tallahassee FL 32399
(850) 414-4322
dewayne.carver@dot.state.fl.us

Gary Sokolow
Systems Planning
605 Suwannee St – MS 32
Tallahassee, Florida 32399-0450
(850)-414-4912
gary.sokolow@dot.state.fl.us

Gina Bonyani
Systems Planning
605 Suwannee St – MS 32
Tallahassee, Florida 32399-0450
(850)-414-4707
gina.bonyani@dot.state.fl.us

Benjamin J. Gerrell, P.E.
Quality Assurance Engineer
605 Suwannee St. MS 32
Tallahassee, Florida 32399-0450
(850) 414-4318
benjamin.gerrell@dot.state.fl.us

Jeremy Fletcher, P.E., P.S.M.
Roadway Quality Assurance Administrator
605 Suwannee Street - MS 32
Tallahassee, Florida 32399-0450
(850) 414-4320
jeremy.fletcher@dot.state.fl.us

Andre Pavlov, P.E.
Assistant State Structures Design
Engineer
605 Suwannee St., MS 33
Tallahassee, Florida 32399-0450
(850) 414-4293
andre.pavlov@dot.state.fl.us

Alan S. El-Urfali, P.E.
State Traffic Services Program Manager
605 Suwannee St., MS 36
Tallahassee, Florida 32399-0450
(850) 410-5416
alan.el-urfali@dot.state.fl.us

Catherine (Katey) Earp, P.E.
Drainage Design Engineer
605 Suwannee St. MS 32
Tallahassee, Florida 32399-0450
850-414-4171
catherine.earp@dot.state.fl.us

**CHAPTER TECHNICAL ADVISORS
(continued)**

Chris A. Wiglesworth
Transit Planner
605 Suwannee St. MS 26
Tallahassee, Florida 32399-0450
850-414-4532
chris.wiglesworth@dot.state.fl.us

Brad Bradley II, P.E., C.P.M.
Quality Assurance Engineer
605 Suwannee St., MS 32
Tallahassee, FL 32399-0450
850-414-4295
brad.bradley@dot.state.fl.us

Florida Greenbook Chapter Subcommittees - 2016

<u>Chapter</u>	<u>Chair</u>
1. Planning	Rick Hall
2. Land Development.....	Margaret Smith
3. Geometric Design	Vacant Howard Webb
4. Roadside Design	Vacant Charles Ramdatt
5. Pavement Design and Construction	Richard Moss
6. Lighting.....	Bernie Masing
7. Rail-Highway Crossings	Daniel Iglesias
8. Pedestrian Facilities	Annette Brennan
9. Bicycle Facilities.....	Annette Brennan
10. Maintenance and Resurfacing.....	Richard Moss
11. Work Zone Safety	Daniel Iglesias
12. Construction.....	Richard Moss
13. Public Transit.....	Vacant Charles Ramdatt
14. Design Exceptions	Richard Moss
15. Traffic Calming.....	Vacant Steve Neff
16. Residential Street Design.....	Richard Baier
17. Bridges and Other Structures	Keith Bryant
18. Signing and Marking.....	Gail Woods
19. Traditional Neighborhood Development	Rick Hall
20. Drainage.....	George Webb

Chapter 1 - Planning

<i>Name</i>	<i>Involvement</i>	<i>Email</i>
Rick Hall	Chair	rickhall@hpe-inc.com
Charles Ramdatt	Member	Charles.Ramdatt@cityoforlando.net
Andy Tilton	Member	atilton@johnsoneng.com
Gabe Matthews	Technical Advisor	gabrielle.matthews@dot.state.fl.us
Regina Colson	Technical Advisor	regina.colson@dot.state.fl.us
Chris Wiglesworth	Technical Advisor	chris.wiglesworth@dot.state.fl.us

Chapter 2 - Land Development

<i>Name</i>	<i>Involvement</i>	<i>Email</i>
Margaret Smith	Chair	mwsmith@pascocountyfl.net
Roger Blaylock	Member	RogerB@santarosa.fl.gov
Richard Diaz	Member	richard@diazpearson.com
Rick Hall	Member	rickhall@hpe-inc.com
Mark Massaro	Member	mark.massaro@ocfl.net
George Webb	Member	GWebb@pbcgov.org
Gabe Matthews	Technical Advisor	gabrielle.matthews@dot.state.fl.us
Chris Wiglesworth	Technical Advisor	chris.wiglesworth@dot.state.fl.us

Chapter 3 - Geometric Design

<i>Name</i>	<i>Involvement</i>	<i>Email</i>
Vacant Howard Webb	Chair	howard.webb@dot.state.fl.us
Robert Behar	Member	bbeharr@rjbehar.com
Keith Bryant	Member	kbryant@baycountyfl.gov
Ken Dudley	Member	county.engineer@taylorcountygov.com
Andres Garganta	Member	andy.garganta@wantmangroup.com
Ramon Gavarrete	Member	rgavarrete@alachuacounty.us
Rick Hall	Member	rickhall@hpe-inc.com
Daniel Iglesias	Member	daniel.iglesias@dot.state.fl.us
Gaspar Miranda	Member	GXM@miamidade.gov

Allen Schrumpf	Member	aschrumpf@drmp.com
Fred Schneider	Member	fschneider@co.lake.fl.us
Mark Massaro	Member	mark.massaro@ocfl.net
Diana Almodovar	Technical Advisor	diana.almodovar@ocfl.net
Humberto Castellero	Technical Advisor	humberto.castillero@dot.state.fl.us
William Corbett	Technical Advisor	wcorbett@capecoral.net
Christine Lofye	Technical Advisor	christine.lofye@ocfl.net
Ghulam Qadir	Technical Advisor	ghulam.qadir@ocfl.net
Frank Yokiell	Technical Advisor	frank.yokiell@ocfl.net

Chapter 4 - Roadside Design

<i>Name</i>	<i>Involvement</i>	<i>Email</i>
Charles Ramdatt	Chair	Charles.Ramdatt@cityoforlando.net
Robert Behar	Member	bbeharr@rjbehar.com
Keith Bryant	Member	kbryant@baycountyfl.gov
Roger Blaylock	Member	RogerB@santarosa.fl.gov
Andres Garganta	Member	andy.garganta@wantmangroup.com
Ramon Gavarrete	Member	rgavarrete@alachuacounty.us
Gene Howerton	Member	Gene.Howerton@arcadis.com
Milton Martinez	Member	milton.martinez@tampagov.net
Gaspar Miranda	Member	GXM@miamidade.gov
David Kuhlman	Member	david.f.kuhlman@fpl.com
Charles Ramdatt	Member	Charles.Ramdatt@cityoforlando.net
Kathy Thomas	Member	kathy.thomas@dot.state.fl.us
Allen Schrumpf	Member	aschrumpf@drmp.com
William Corbett	Technical Advisor	wcorbett@capecoral.net
Jeremy Crowe	Technical Advisor	jeremy.crowe@cityoforlando.net
Gevin McDaniel	Technical Advisor	gevin.mcdaniel@dot.state.fl.us

Chapter 5 - Pavement Design and Construction

<i>Name</i>	<i>Involvement</i>	<i>Email</i>
Richard Moss	Chair	richard.moss@dot.state.fl.us
Robert Behar	Member	bbehar@rjbehar.com
Ken Dudley	Member	county.engineer@taylorcountygov.com
Andres Garganta	Member	andy.garganta@wantmangroup.com
Daniel Iglesias	Member	daniel.iglesias@dot.state.fl.us
Margaret Smith	Member	mwsmith@pascocountyfl.net
Gail Woods	Member	Gwoods@wbq.com
Frank Kreis	Technical Advisor	frank.kreis@dot.state.fl.us
Susan Ussach	Technical Adviosr	susan.ussach@cityoforlando.net

Chapter 6 - Lighting

<i>Name</i>	<i>Involvement</i>	<i>Email</i>
Bernie Masing	Chair	bernie.masing@dot.state.fl.us
Keith Bryant	Member	kbryant@baycountyfl.gov
Mark Massaro	Member	mark.massaro@ocfl.net
Juvenal Santana	Member	JSantana@miamigov.com
Allen Schruppf	Member	aschrumpf@drmp.com
George Webb	Member	GWebb@pbcgov.org
Luis Alvan	Technical Advisor	luis.alvan@ocfl.net
Rochelle Garrett	Technical Advisor	rochelle.garrett@dot.state.fl.us
Amy Harris	Technical Advisor	aharris@pbcgov.org
Chester Henson	Technical Advisor	chester.henson@dot.state.fl.us
Keith Slater	Technical Advisor	keith.slater@dot.state.fl.us
Frank Yokiell	Technical Advisor	frank.yokiell@ocfl.net

Chapter 7 - Rail Highway Crossings

<i>Name</i>	<i>Involvement</i>	<i>Email</i>
Daniel Iglesias	Chair	daniel.iglesias@dot.state.fl.us
Keith Bryant	Member	kbryant@baycountyfl.gov
Gene Howerton	Member	Gene.Howerton@arcadis.com
Mark Massaro	Member	mark.massaro@ocfl.net
Gaspar Miranda	Member	GXM@miamidade.gov
Richard Moss	Member	richard.moss@dot.state.fl.us
Charles Ramdatt	Member	Charles.Ramdatt@cityoforlando.net
Andy Tilton	Member	atilton@johnsoneng.com
George Webb	Member	GWebb@pbcgov.org
Emilio Corrales	Technical Advisor	emilio.corrales@dot.state.fl.us
Andre Goins	Technical Advisor	andre.goins@dot.state.fl.us

Chapter 8 - Pedestrian Facilities

<i>Name</i>	<i>Involvement</i>	<i>Email</i>
Annette Brennan	Chair	annette.brennan@dot.state.fl.us
Richard Baier	Member	richard.baier@sumtercountyfl.com
Robert Behar	Member	bbehar@rjbehar.com
Richard Diaz	Member	richard@diazpearson.com
Andres Garganta	Member	andy.garganta@wantmangroup.com
Rick Hall	Member	rickhall@hpe-inc.com
Gene Howerton	Member	Gene.Howerton@arcadis-us.com
Daniel Iglesias	Member	daniel.iglesias@dot.state.fl.us
Mark Massaro	Member	mark.massaro@ocfl.net
Milton Martinez	Member	milton.martinez@tampagov.net
Andy Tilton	Member	atilton@johnsoneng.com
Kathy Thomas	Member	kathy.thomas@dot.state.fl.us
George Webb	Member	gwebb@pbcgov.org
Gina Bonyani	Technical Advisor	gina.bonyani@dot.state.fl.us
George Borchik	Technical Advisor	george.borchik@dot.state.fl.us
Mary O'Brien	Technical Advisor	mary.obrien@dot.state.fl.us

Christine Lofye	Technical Advisor	christine.lofye@ocfl.net
Gary Sokolow	Technical Advisor	gary.sokolow@dot.state.fl.us
Alan El-Urfali	Technical Advisor	alan.el-urfali@dot.state.fl.us

Chapter 9 - Bicycle Facilities

<i>Name</i>	<i>Involvement</i>	<i>Email</i>
Annette Brennan	Chair	annette.brennan@dot.state.fl.us
Robert Behar	Member	bbeharr@rjbehar.com
Rodney Chamberlain	Member	rodney.chamberlain@dot.state.fl.us
Andres Garganta	Member	andy.garganta@wantmangroup.com
Gene Howerton	Member	Gene.Howerton@arcadis-us.com
Daniel Iglesias	Member	daniel.iglesias@dot.state.fl.us
Milton Martinez	Member	milton.martinez@tampagov.net
Mark Massaro	Member	mark.massaro@ocfl.net
Bernie Masing	Member	bernie.masing@dot.state.fl.us
Kathy Thomas	Member	kathy.thomas@dot.state.fl.us
Andy Tilton	Member	atilton@johnsoneng.com
George Webb	Member	GWebb@pbcgov.org
Gail Woods	Member	gwoods@wbq.com
George Borchik	Technical Advisor	george.borchik@dot.state.fl.us
Christine Lofye	Technical Advisor	christine.lofye@ocfl.net
Mary O'Brien	Technical Advisor	mary.obrien@dot.state.fl.us
Gary Sokolow	Technical Advisor	gary.sokolow@dot.state.fl.us

Chapter 10 – Maintenance and Resurfacing

<i>Name</i>	<i>Involvement</i>	<i>Email</i>
Richard Moss	Chair	richard.moss@dot.state.fl.us
Ramon Gavarrete	Member	rgavarrete@alachuacounty.us
Gene Howerton	Member	Gene.Howerton@arcadis.com
Bernie Masing	Member	bernie.masing@dot.state.fl.us
Allen Schruppf	Member	aschrumpf@drmp.com
Ben Gerrell	Technical Advisor	benjamin.gerrell@dot.state.fl.us

Chapter 11 - Work Zone Safety

<i>Name</i>	<i>Involvement</i>	<i>Email</i>
Daniel Iglesias	Chair	daniel.iglesias@dot.state.fl.us
Richard Baier	Member	richard.baier@sumtercountyfl.com
Robert Behar	Member	bbehar@rjbehar.com
Keith Bryant	Member	kbryant@baycountyfl.gov
Andres Garganta	Member	andy.garganta@wantmangroup.com
David Kuhlman	Member	david.f.kuhlman@fpl.com
Juvenal Santana	Member	JSantana@miamigov.com
John Veilleux	Member	veilleuxj@cityofgainesville.org
Gail Woods	Member	gwoods@wbq.com
Gevin McDaniel	Technical Advisor	gevin.mcdaniel@dot.state.fl.us

Chapter 12 - Construction

<i>Name</i>	<i>Involvement</i>	<i>Email</i>
Richard Moss	Chair	richard.moss@dot.state.fl.us
Ramon Gavarrete	Member	rgavarrete@alachuacounty.us
Bernie Masing	Member	bernie.masing@dot.state.fl.us
Andy Tilton	Member	atilton@johnsoneng.com
Vacant	Technical Advisor	

Chapter 13 - Public Transit

<i>Name</i>	<i>Involvement</i>	<i>Email</i>
<u>Vacant</u> Charles Ramdatt		Chair Charles.Ramdatt@cityoforlando.net
Annette Brennan	Member	Annette.Brennan@dot.state.fl.us
Richard Diaz	Member	richard@diazpearson.com
Charles Ramdatt	Member	Charles.Ramdatt@cityoforlando.net
Chris Wiglesworth	Technical Advisor	chris.wiglesworth@dot.state.fl.us

Chapter 14 - Design Exceptions

<i>Name</i>	<i>Involvement</i>	<i>Email</i>
Richard Moss	Chair	richard.moss@dot.state.fl.us
Richard Baier	Member	richard.baier@sumtercountyfl.com
Robert Behar	Member	bbeharr@rjbehar.com
Roger Blaylock	Member	RogerB@santarosa.fl.gov
Andres Garganta	Member	andy.garganta@wantmangroup.com
Ramon Gavarrete	Member	rgavarrete@alachuacounty.us
Daniel Iglesias	Member	daniel.iglesias@dot.state.fl.us
Bernie Masing	Member	bernie.masing@dot.state.fl.us
Milton Martinez	Member	milton.martinez@tampagov.net
Gaspar Miranda	Member	GXM@miamidade.gov
Margaret Smith	Member	mwsmith@pascocountyfl.net
Gail Woods	Member	gwoods@wbq.com
David Kuhlman	Member	david.f.kuhlman@fpl.com
Brad Bradley	Technical Advisor	brad.bradley@dot.state.fl.us
Jeremy Fletcher	Technical Advisor	jeremy.fletcher@dot.state.fl.us
John Fowler	Technical Advisor	john.fowler@dot.state.fl.us

Chapter 15 - Traffic Calming

<i>Name</i>	<i>Involvement</i>	<i>Email</i>
Vacant Steve Neff	Chair	sneff@capecoral.net
Andres Garganta	Member	andy.garganta@wantmangroup.com
Ramon Gavarrete	Member	rgavarre@hcbcc.org
Mark Massaro	Member	mark.massaro@ocfl.net
Gaspar Miranda	Member	GXM@miamidade.gov
Margaret Smith	Member	mwsmith@pascocountyfl.net
Kathy Thomas	Member	kathy.thomas@dot.state.fl.us
William Corbett	Technical Advisor	wcorbett@capecoral.net
Gary Sokolow	Technical Advisor	gary.sokolow@dot.state.fl.us
Jeremy Crowe	Technical Advisor	jeremy.crowe@cityoforlando.net
Frank Yokiel	Technical Advisor	frank.yokiel@ocfl.net

Chapter 16 - Residential Street Design

<i>Name</i>	<i>Involvement</i>	<i>Email</i>
Richard Baier	Chair	richard.baier@sumtercountyfl.com
Robert Behar	Member	bbehar@rjbehar.com
Bernie Masing	Member	bernie.masing@dot.state.fl.us
Mark Massaro	Member	mark.massaro@ocfl.net
Ramon Gavarrete	Member	rgavarrete@alachuacounty.us
Juvenal Santana	Member	JSantana@miamigov.com
Andy Tilton	Member	atilton@johnsoneng.com
John Veilleux	Member	veilleuxj@cityofgainesville.org
Jeremy Crowe	Technical Advisor	jeremy.crowe@cityoforlando.net

Chapter 17 - Bridges and Other Structures

<i>Name</i>	<i>Involvement</i>	<i>Email</i>
Keith Bryant	Chair	kbryant@baycountyfl.gov
Annette Brennan	Member	Annette.Brennan@dot.state.fl.us
Rodney Chamberlain	Member	rodney.chamberlain@dot.state.fl.us
Mark Massaro	Member	mark.massaro@ocfl.net
Andre Pavlov	Technical Advisor	andre.pavlov@dot.state.fl.us

Chapter 18 – Signing and Marking

<i>Name</i>	<i>Involvement</i>	<i>Email</i>
Gail Woods	Chair	Gwoods@wbq.com
Robert Behar	Member	bbehar@rjbehar.com
Daniel Iglesias	Member	daniel.iglesias@dot.state.fl.us
Milton Martinez	Member	milton.martinez@tampagov.net
Gaspar Miranda	Member	GXM@miamidade.gov
George Webb	Member	GWebb@pbcgov.org
William Corbett	Technical Advisor	wcorbett@capecoral.net
Jeremy Crowe	Technical Advisor	jeremy.crowe@cityoforlando.net
Chester Henson	Technical Advisor	chester.henson@dot.state.fl.us
Gail Holley	Technical Advisor	gail.holley@dot.state.fl.us
Christine Lofye	Technical Advisor	christine.lofye@ocfl.net
Alan El-Urfali	Technical Advisor	alan.el-urfali@dot.state.fl.us

Chapter 19 - Traditional Neighborhood Development (TND) Subcommittee

<i>Name</i>	<i>Involvement</i>	<i>Email</i>
Rick Hall	Chair	rickhall@hpe-inc.com
Richard Baier	Member	richard.baier@sumtercountyfl.com
Andres Garganta	Member	andy.garganta@wantmangroup.com
Billy Hattaway	Member	billy.hattaway@cityoforlando.net
Bernie Masing	Member	bernie.masing@dot.state.fl.us
Mark Massaro	Member	mark.massaro@ocfl.net
Andy Tilton	Member	atilton@johnsoneng.com
John Veilleux	Member	veilleuxj@cityofgainesville.org
Jeremy Crowe	Technical Advisor	jeremy.crowe@cityoforlando.net

Chapter 20 - Drainage

<i>Name</i>	<i>Involvement</i>	<i>Email</i>
George Webb	Chair	GWebb@pbcgov.org
Robert Behar	Member	bbehar@rjbehar.com
Andres Garganta	Member	andy.garganta@wantmangroup.com
Gene Howerton	Member	Gene.Howerton@arcadis.com
Gaspar Miranda	Member	GXM@miamidade.gov
Andy Tilton	Member	atilton@johnsoneng.com
Alex Barrios	Technical Advisor	barria@miamidade.gov
Katey Earp	Technical Advisor	catherine.earp@dot.state.fl.us
Omelio Fernandez	Technical Advisor	OFernand@pbcgov.org
Jim Hunt	Technical Advisor	Jim.Hunt@Cityoforlando.net
Ken Todd	Technical Advisor	Ktodd@pbcgov.org

Minutes (Draft)

FLORIDA GREENBOOK ADVISORY COMMITTEE MEETING

Wednesday, April 13, 2016, 8:00 AM – 4:30 PM

Thursday, April 14, 2016, 8:30 AM – 11:30 PM

FDOT's Deland Operations Center, Sailfish Meeting Room
1650 N. Kepler Road
Deland, Florida 32724

Wednesday, April 13, 2016

Attendance

The following members, associate members, Department staff, technical advisors and public were in attendance, either in-person or remotely via Go-To-Meeting.

- **Members**

Milton Martinez, John Veilleux, Kathy Thomas, Howard Webb, Robert Behar, Charles Ramdatt, Gail Woods, Annette Brennan, George Webb, Ramon Gavarrete, Chris Tavella, Andy Tilton, Jared Perdue, Andy Garganta, Gaspar Miranda, Juvenal Santana, Richard Moss, Bernie Masing, Richard Baier, Steve Neff, Margaret Smith, Rick Hall; Gene Howerton, Richard Diaz

- **Associate Members**

Fred Schneider, Mark Massaro, David F. Kuhlman

- **FDOT Staff, Technical Advisors and Public**

Tim Lattner, Michael Shepard, Mary Anne Koos, Mary Jane Hayden, Paul Hiers, Alan El-Urfali, Gail Holley, Frank Yokiell, Susan Ussach, Jeremy Crowe, Christine Lofye, Kevin Miller, Jeremy Fletcher, Gabe Matthews, Regina Colson, Maria Cahill

General Information

- **Welcome and Introductions (Michael Shepard & Mary Anne Koos)**

Florida Greenbook Committee and Associate Member Changes - Changes in membership for the Greenbook Committee were discussed and a new member, John Veilleux, City of Gainesville (urban local government for District 2) was introduced. Mr. Veilleux replaces Dave Cerlanek, who is now working for FDOT. Ramon Gavarrete will be leaving Highlands County in May to join Alachua County's Public Works Department, and will

transition from a voting Committee member to an Associate member. He was thanked for his leadership as chair of Chapter 14 – Design Exceptions and for his years of service.

Regina Colson joined as the Technical Advisor for Chapter 1 – Planning. Maria Cahill, the Technical Advisor for Chapter 2 – Land Development, is now the Director, Florida Transportation Technology Transfer Center at the University of Florida Transportation Institute. Ms. Cahill will continue supporting the work of the Florida Greenbook Committee.

- **Review Contact Information (Mary Anne Koos)**

The Committee Membership list was circulated for everyone to update their contact information.

- **Update Subcommittee Assignments (Mary Anne Koos)**

The list of current chairs for the chapter subcommittees was reviewed, and chair assignments updated. Richard Moss indicated an interest in serving as the chair of Chapter 14 when it becomes vacant. Members also updated their subcommittee membership preferences.

- **Review January 2016 Meeting Minutes (Mary Anne Koos)**

The draft minutes were sent electronically on March 31, 2016 to all members for comment. No revisions were requested and the minutes are considered approved.

- **Rulemaking**

The 2016 Florida Greenbook (Draft) has been submitted for rulemaking to FDOT's General Counsel Office. The version in the green 3-ring binder that committee members received in January has been updated slightly. The revised version was e-mailed in conjunction with the draft minutes. In addition, a modification is proposed for the 2016 draft regarding Design Speed and will be discussed later in the morning.

- **Sunshine Law**

Ms. Koos reminded the committee that we are required to follow Florida's Sunshine law requirements. All discussion between voting members must be conducted in a public meeting.

Presentation of Proposed Revisions for 2018 Florida Greenbook

All revisions shown today, except for the table on design speed in Chapter 3, are for revisions to the 2018 Greenbook Edition. The meeting package includes the revisions that will be discussed today and can be added to the ring binders as an update to the chapters. Ms. Koos reviewed the color-coding of the text for the group. Green-highlighted text has already been approved by the Committee in previous meetings. Yellow are notes that will be deleted in the final format or are areas that need follow up discussion.

- **Chapter 1 – Planning (Rick Hall)**

Mary Anne Koos presented the proposed changes to the chapter, as shown in the draft dated April 6, 2016.

- Section B.2.a Basic Classification was edited to be based on land use, and a reference to FHWA’s Highway Functional Classification Concepts, Criteria and Procedures, 2013 Edition was added. The terminology was updated to match the Introduction definitions and there was agreement to reorganize as Arterial, Collector and Local subsections to follow the same order used in tables elsewhere.
- Section B.2.b Classification Modifications was updated to reflect land use and context and a reference to the 21st Century Land Development Code, which links land use to transportation corridors, was added. Table 1-1 Functional Classification Modifications was added as an example of how functional classification and land use can be linked. A narrative was added to define rural versus urban in terms of land use, not presence of curb and gutter. References to other Greenbook chapters that support context-based design were added.
- References section was updated.

- **Chapter 2 – Land Development (Margaret Smith)**

Mary Anne Koos presented the proposed changes to the chapter, as shown in the draft dated April 6, 2016.

- Section A Introduction was edited to update language and be more positive. Context-based street design was introduced: streets are sized and scaled to accurately serve all road users. The first sentence of page 2-2 was revised to read “creation of high quality networks.”
- Section B Objectives was updated to be more grammatically correct and current. George Webb questioned what the bullet on “economic design” means. This bullet will be edited in the breakout session.

- Section C 1 Development Types and Area Types was added to describe the following development patterns – Conventional Suburban, Traditional Neighborhood Design (TND), Transit-Oriented Design (TOD). References to APA’s 21st Century Land Development Code and the Department’s Traditional Neighborhood Development Handbook were added. The term “rethinks” was revised to “examines”.
- Section C.2 Network Design will be reviewed in the breakout section to review the 6th bullet, which addresses posted speed. A suggestion was made for the bullet on roundabouts to add the full reference for NCHRP 672 and include a reference to Chapter 15 – Traffic Calming. The bullet on one-way streets was revised to remove “local” and add “highways”. The bullet on vehicle speeds was revised to remove “local” and to replace “limit” with “promote safe”.
- Section D Coordination was edited to remove “Conflict” from the title. A paragraph was added to provide information on the Florida Metropolitan Planning Organization Advisory Council since they can be a valuable resource in managing land development.
- Section E.2 was revised from “Police Power” to “Regulatory Authority”.
- Section F References was added to the Chapter.
- Mark Massaro asked whether language regarding Road Diets was needed. Committee will consider discussing tomorrow when they talk about future revisions.

- **Introduction – (Howard Webb)**

Howard Webb and Mary Anne Koos presented the proposed changes to the Introduction, as shown in the draft dated April 7, 2016.

- Section 336.045(2), F.S. was added to the narrative to clarify how membership is established.
- Information on the how the Greenbook criteria apply to the National Highway System was added, along with a link to maps showing the system.
- Paragraph describing how the standards in the Greenbook are applied to different types of projects, new construction, reconstruction, and resurfacing was revised. Guidance on Chapter 10 – Maintenance and Resurfacing and Chapter 14 – Design Exceptions apply was added. The Committee requested that a definition for “reconstruction” be developed for the Definition of Terms section.
- Clear Zone – the definition was revised to be consistent with AASHTO.
- The term Horizontal Clearance was revised to Lateral Offset, and the definition revised to be consistent with AASHTO.

- **Chapter 3 – Geometric Design (Howard Webb)**

Mary Anne Koos requested the Committee review two proposed changes for the **2016 Greenbook**, as shown in the draft dated April 7, 2016. The changes affect Table 3 – 1 Recommended Design Speed and Table 3 – 5 Horizontal Curvature.

- Table 3 – 1 Recommended Design Speed - Ms. Koos explained that the revisions made during the January 2016 meeting by the Committee fall outside the limits suggested by AASHTO. A revised Table 3 – 1 was presented that includes terrain as a factor to be considered when selecting design speed and is consistent with the limits in the AASHTO Greenbook. The Committee voted unanimously to accept the revised table.
- Table 3 – 5 Horizontal Curvature - Ms. Hayden explained the values have been added for 20 and 25 mph for HSO, which had been requested at the January meeting. These values are based on 2004 AASHTO friction values (to match the rest of the table). This table, and the associated figures, will need to be updated for 2018 since the friction factors changed in 2011 AASHTO. The Committee agreed with this revision.

Howard Webb and Mary Anne Koos then presented the proposed revisions for the **2018 Greenbook**, as shown in the draft dated April 7, 2016.

- Section C.7.d Sidewalks was revised to include references to additional design criteria found in Section C.10.a.3 – Sidewalks and Curb Ramps of this chapter, Chapter 8 - Pedestrian Facilities, AASHTO’s Guide for the Planning, Design and Operation of Pedestrian Facilities (2004), and Section 4.17.1 Sidewalks of AASHTO’s Policy on Geometric Design of Highways and Streets (2011).
- Section C.7.f Islands was added. It includes criteria for three types of islands – Channelizing, Divisional, and Refuge. Information on the purpose, location, and dimensions is included. References to the AASHTO Greenbook, AASHTO Roadside Design Guide, MUTCD, and Design Standards were included.
- Figure 3-9 General Types and Shapes of Islands and Medians has an arrow pointing in the wrong direction and will need to be revised.
- Figure 3-13 Pedestrian Refuge Island shows the pedestrian crossing warning sign on the far side of the crosswalk and should be replaced.
- Section C.7.g. Roadside Clear Zone and Lateral Offset was revised to include two sub sections, Clear Zone and Lateral Offset.
- Section C.7.g.1 Clear Zone was rewritten to clarify the purpose, location, and width of clear zones. The type of slopes were classified, and references to when additional clear zone width or protection should be included in the design.

- Table 3 – 15 Minimum Width of Clear Zone was added, with values consistent with AASHTO criteria. The footnotes in the Table apply to very low volume roads and may be developed as their own section or table for discussion at the 2017 meeting of the Greenbook Committee.
- Figure 3 – 14 Clear Zone Plan View, Figure 3 – 15 Basic Clear Zone Concept and Figure 3 – 16 Adjusted Clear Zone Concept were added.
- Figure 3 – 17 Roadside Ditches – Bottom Width 0 to 4 feet and Figure 3 – 18 Roadside Ditches Bottom Width \geq 4 Feet were added.
- Section C.7.g.2 Lateral Offset was added. This is a new section that provides lateral offset requirements for roadside features and fixed objects.
- Table 3 – 16 Lateral Offset was added, and provides offset values for above ground fixed objects and drop off hazards, consistent with AASHTO criteria. For water bodies and canal hazards, the table references Chapter 4 – Roadside Design of the Florida Greenbook for criteria.
- Section C.7.g.3 Roadside Slopes was revised to encourage flatter slopes (1:6) but continues to allow for a 1:4 slope. Conditions were included for slopes as steep as 1:3, and references made to Figures 3 – 17 and 3 – 18.

Subcommittee Meetings for Final Drafting of 2018 Revisions

Rather than breaking out into subcommittees to address comments from the morning's chapter presentations on Chapters 1 and 2, the full committee decided to work together on finalizing the Introduction and Chapter 3 – Geometric Design.

- **Introduction (Howard Webb)**

- Reconstruction – The definition was revised, based upon FHWA's definition. It now reads "Reconstruction is defined as streets and highways that are rebuilt primarily along existing alignment. Reconstruction normally involves full-depth pavement replacement. Other work that would fall into the category of reconstruction would be adding lanes adjacent to an existing alignment, changing the fundamental character of the roadway (e.g., converting a two-lane highway to a multi-lane divided arterial) or reconfiguring intersections and interchanges."
- Border Area – The committee requested a definition for border area be added that would identify all the elements that are part of the "border".

- **Chapter 3 – Geometric Design (Howard Webb)**
 - Section C.7.f Islands was revised regarding the placement of mast arms in islands and medians. The third sentence in the second paragraph was revised to read “While mast arms are discouraged in channelizing islands, when they are used the minimum lateral offset as shown in Table 3 – 16 Lateral Offset shall be provided.” The last sentence “Mast arms shall not be placed in medians.” was moved to C.7.e Medians. The final placement will be worked out for 2018.
 - Section C.7.f.1 was revised to move a portion of the fourth paragraph regarding lateral offset to Section C.7.f. The remainder was deleted. The last sentence of second paragraph was updated to use correct terminology (flush shoulder, not rural, and streets and highways, not area).
 - Figure 3 – 13 should be revised to use either photos or drawings which correctly illustrate the pavement markings and signage to be included at pedestrian crossings in conjunction with a refuge island. Examples of both yield and stop conditions should be included. The revised Figure should be brought back to the Committee for approval in 2017.
 - Table 3 – 5 Horizontal Curves is based on $e_{max} = 0.10$, which doesn’t seem to make sense and also doesn’t appear to match Figure 3 – 4 Stopping Sight Distance on Curves. Committee decided to review all of the tables, figures, and calculations for 2018 to ensure consistency with the 2011 AASHTO Greenbook.
 - Section C.7.g.1 should include information on what is considered to be an “obstruction” for lateral clearance and clear zone. Provide guidance on acceptable curb heights.
 - The illustrations accompanying Table 3 – 22 Minimum Acceleration Lengths for Entrance Terminals, as an example, should be reviewed to remove specific lane width callouts. This would be proactive in supporting Complete Streets and allow flexibility. All the figures and tables should be reviewed for lane width and other unintended dimensions.

Chapter Report and Vote on 2018 Chapter Revisions

The Committee reconvened for a final review and adoption of the proposed revisions to the Introduction and Chapter 3 – Geometric Design.

- **Introduction**
 - Mr. Webb gave a summary of the proposed changes, including the revised definitions for Clear Zone, Lateral Offset, and Reconstruction.

- A motion was made by Howard Webb to approve the changes, seconded by Richard Baier. The changes were approved unanimously.

- **Chapter 3 – Geometric Design**

- Mr. Webb gave a summary of the proposed changes, including the expanded references to sidewalk design criteria, new sections for islands, roadside clear zone and lateral offset, and revised section for roadside slopes. The entire Greenbook should be reviewed for consistency with 2011 AASHTO Greenbook values. Existing figures and illustrations will be reviewed to remove unnecessary geometric design requirements such as lane width to ensure flexibility.
- Moved by Howard Webb to approve the changes, seconded by Richard Baier. The changes were approved unanimously.

Chapter Report and Vote on 2018 Chapter Revisions

The Committee reconvened after lunch for a final review and adoption of the proposed revisions to Chapter 1 – Planning and Chapter 2 – Land Development.

- **Chapter 1 – Planning**

- Rick Hall and Ms. Koos gave a summary of the proposed changes, including update of Classification Modifications to reflect land use and context, and new references to FHWA’s Highway Functional Classification Concepts, Criteria and Procedures, 2013 Edition and APA’s 21st Century Land Development Code.
- Moved by Andy Tilton to approve the changes, seconded by Gail Woods. The changes were approved unanimously.

- **Chapter 2 – Land Development**

- Margaret Smith and Ms. Koos gave a summary of the proposed changes, including an introduction of Context-based street design. A section describing a variety of development patterns was added, and included Conventional Suburban, Traditional Neighborhood Design (TND), and Transit-Oriented Design (TOD). Information on the Florida Metropolitan Planning Organization Advisory Council (MPOAC) was added, along with a new reference section.
- Moved by Rick Hall to approve the changes, seconded by Andy Garganta. The changes were approved unanimously.

Presentation of Proposed Revisions for 2018 Florida Greenbook and Vote on Chapter Revisions (continued)

Ramon Gavarrete and Mary Anne Koos presented the proposed changes to Chapter 14 – Design Exceptions, as shown in the draft dated April 7, 2016.

- **Chapter 14 – Design Exceptions (Ramon Gavarrete)**
 - Section A General and Section B Design Exceptions (old numbering) were merged to highlight the 13 AASHTO controlling elements and streamline the information. A fourth paragraph was added regarding the documentation needed when proposed design elements, other than the 13 controlling elements do not meet the criteria contained in the Florida Greenbook.
 - Section B Recommendations for Approval of Design Exceptions was revised to clarify that processing of exceptions that involve a state or federal facility must be processed through the Department’s district office and follow the process given in Chapter 23 of the PPM, Volume 1.
 - Section C Coordination of Design Exceptions was expanded to clarify that the Department will only be involved if the proposed project on a local road is part of a Department project.
 - Section D Justification and Documentation of Design Exceptions added a reference to FHWA’s Mitigation Strategies for Design Exceptions and Chapter 23 of the PPM, Volume 1 for information on benefit/cost analysis.
 - The committee discussed whether further guidance is needed for documentation of deviations from criteria other than the 13 controlling elements identified by AASHTO. Do engineering ethics and professional standards guide engineers sufficiently? Some members felt that it was beneficial to clarify expectations of documentation. The committee agreed the chapter will need further work once FHWA revises its guidance on the 13 controlling elements.
 - The committee agreed that a consistent term (maintaining agency or authority) should be used to describe who is the responsible party for developing, approving and retaining the Design Exception. The term should be included in the Introduction.

The following revisions were then made to the draft chapter:

- Revise the title to Design Exceptions and Variations.
- Section A General was revised to move the fourth paragraph regarding documentation for design elements other than the 13 controlling elements to a new section called F Design Variations.

- Section F Design Variations was added and reads “When proposed design elements other than the 13 controlling Design Elements do not meet the criteria contained in this Manual, sufficient detail and justification of such deviations documented by the Responsible Professional Engineer shall be provided to the responsible agency.
- Moved by Andy Garganta to approve the changes, seconded by Ramon Gavarrete. The changes were approved unanimously.

FDOT Complete Streets Update (Michael Shepard)

Michael Shepard provided an overview of FDOT’s Complete Streets progress. The Department has a web page at <http://www.flcompletestreets.com>. George Webb asked if FDOT has considered midblock crossing criteria with the Complete Streets initiative. Annette Brennan, Michael Shepard, Jared Perdue, and Mary Anne Koos responded that the FDOT Traffic Engineering Manual (TEM) provides guidance on midblock crossings. Christine Lofye explained that the TEM provides some reduced requirements for installation of midblock crossings (require fewer pedestrian crossings/hour than MUTCD).

Andy Garganta asked if the PPM had been updated with the vertical curve criteria for a 2.5-ft object height (per AASHTO). Michael Shepard answered that the PPM will keep the 6”-in object height for new construction criteria, but changed the RRR criteria to be less conservative and use the 2.5-ft object height.

Future Greenbook Revisions (Mary Anne Koos)

Mary Anne Koos presented options for the Committee’s future work. The entire Greenbook needs to be reviewed to be consistent with the 2011 AASHTO Greenbook.

- Chapter 3 – Geometric Design needs to be updated for consistent use of the term “lateral offset” and review of the horizontal curve tables/figures.
- Chapter 4 – Roadside Design also needs to be revised for the changes to clear zone & lateral offset.
- Chapter 14 – Design Exceptions will need to be revised to reflect changes FHWA may make regarding the 13 controlling elements.
- Chapter 17 – Bridges and Other Structures should be updated to reflect changes in Florida Statutes and the Structures Design Guidelines. Andre Pavlov has already drafted some revisions.
- Chapter 18 – Signing and Marking will need to be revised to include the reference to the Speed Zoning Manual for reduced speeds in school zones.
- Chapter 19 – Traditional Neighborhood Development could be updated to reflect Complete Streets. Rick Hall suggested this chapter also include sight distance criteria, rather than continue to refer to Chapter 3.

The Greenbook Committee adjourned for the day at 4:30 PM.

Thursday, April 14, 2016

Continuing Education Credits for PE and AICP Certification (Mark Massaro)

Mark Massaro contacted Nancy Wilkins, Florida Board of Professional Engineers yesterday and asked whether participation in Florida Greenbook Committee activities would qualify for professional development hours (PDHs). Her response was positive since the Committee works to establish engineering criteria. Ms. Koos asked the group if they would like FDOT to follow up with the Board on obtaining credits, which they agreed with. Charles Ramdatt also asked if credits for AICP certification could be provided. Ms. Koos circulated the sign in sheets where members added their PE and AICP numbers.

Future Greenbook Revisions (Mary Anne Koos)

Ms. Koos provided a refresher of which chapters were identified for revisions during the next year (2017): Chapter 3 – Geometric Design, Chapter 4 – Roadside Design, Chapter 14 – Design Exceptions, Chapter 17 – Bridges and Other Structures, Chapter 18 – Signing and Marking, and Chapter 19 – Traditional Neighborhood Development. The group was still in agreement with these chapters, except for Chapter 17. The Chapter Chair, Keith Bryant was not able to join the meeting. Ms. Koos will follow up with him later. It was noted that Chapters 3 and 18 will probably not be large efforts.

Presentation on Reduced Speed Zone Criteria (Alan El-Urfali and Gail Holley)

Alan El-Urfali and Gail Holley, FDOT Traffic Operations Office, presented on the need to include further guidance for posting of reduced speeds in school zones via GoToMeeting. They felt the best fit for this topic is in the [Manual on Speed Zoning for Highways, Roads and Streets in Florida](#), which is adopted by rule (Rule 14-15.012 F.A.C). This Manual provides guidelines and recommended procedures for establishing uniform speed zones on State, Municipal and County roadways throughout the state of Florida.

The Manual on Speed Zoning already has language for school zones in Section 15.1 Time Period Speed (Regulatory). FDOT Traffic Operations Office proposes to create a stand-alone section for school zones and add to it. These proposed revisions will need to be adopted through rulemaking, planned for later in 2016. Once adopted, Chapter 18 of the Greenbook could be revised in 2017 to reference the Manual and be included in the 2018 Greenbook.

Breakout Sessions for Future Greenbook Revisions

The Committee broke out into smaller groups by Chapter to develop a work plan for future Chapter revisions.

Chapter Chair Reports for Future Greenbook Revisions and Discussion

- **Chapter 3 – Geometric Design (Mary Anne Koos)**
 - Housekeeping for clear zone & lateral offset, in this Chapter and the entire Florida Greenbook.
 - Develop definition for “maintaining agency” for the Introduction and use in Chapter 14 – Design Exceptions. Subcommittee will review entire FGB for consistent use of this term.
 - Review for and update outdated criteria within figures and tables.
 - Review for consistency with 2011 AASHTO Greenbook.

- **Chapter 4 – Roadside Design (Charles Ramdatt)**
 - Review revisions made to the Plans Preparation Manual (PPM), Chapter 4 – Roadside Design and determine what should be included in criteria for local roads.
 - Consider reformatting the Greenbook chapter to be organized similar to the PPM’s chapter.
 - Consider moving Chapter 3, C.7.g Roadside Clear Zone and Lateral Offset to Chapter 4. Everything “shoulders-in” would be in Chapter 3, and everything “shoulders-out” would be in Chapter 4. Include Chapter 3 subcommittee when discussing merging sections of Chapter 3 with Chapter 4.
 - Charles Ramdatt asked that David Kuhlman be included on subcommittee to ensure utilities can participate in the discussion. (Mr. Kuhlman is already a member of this subcommittee).
 - The subcommittee would also like to have additional technical advisors (possibly Tom Bane, Derwood Sheppard, or Jeremy Fletcher).
 - Follow legislation called “Chloe’s Law”, HB 7061, 2016 and how it may ultimately impact local roads. Chloe’s law addresses the protection of water bodies near roadways.
 - Review Utility Accommodation Manual (UAM) for consistency/best practices.
 - Would like to start subcommittee meetings in May/June. FDOT to provide subcommittee with PPM Chapter 4, and Greenbook Chapters 3 and 4.

- **Chapter 18 – Signing and Marking (Gail Woods)**
 - No proposed changes to Chapter other than reference to the Speed Zoning Manual. The materials presented earlier today were a draft, with more changes to come.
 - The subcommittee would like to reconvene in May to review the updated Speed Zoning Manual draft to be provided by Gail Holley.

- **Chapter 19 – Traditional Neighborhood Development (Rick Hall)**
 - This chapter is directly impacted by the Complete Streets revisions proposed for FDOT's other manuals.
 - Section C Planning Criteria should be updated to include the new Context Zones that are currently being finalized for Complete Streets.

Future Meetings (Mary Anne Koos)

Ms. Koos presented the tentative date for the next full Greenbook Committee meeting, scheduled for Wednesday and Thursday, February 22 – 23, 2017 at the Florida Turnpike offices. This date did not work for everyone. The committee preferred to meet a full day Thursday, half day Friday, in February. Ms. Koos agreed to search for an alternative date at the Turnpike. The committee agreed that if needed, the Deland Operations Center is an agreeable alternative. *(Note: The next Florida Greenbook meeting will be February 16 – 17, 2017 at the Florida Turnpike Headquarters. The meeting will be a full day Thursday, 1/2 day Friday).*

The Greenbook Committee adjourned at 11:30 AM.

INTRODUCTION

The purpose of this Manual is to provide uniform minimum standards and criteria for the design, construction, and maintenance of all public streets, roads, highways, bridges, sidewalks, curbs and curb ramps, crosswalks ~~(where feasible)~~, bicycle facilities, underpasses, and overpasses used by the public for vehicular and pedestrian traffic as directed by Sections 20.23(4)(a), 334.044(10)(a), and 336.045, F.S.

In the following statutory excerpts, the term "Department" refers to the Florida Department of Transportation.

Section 20.23, F.S. Department of Transportation. There is created a Department of Transportation which shall be a decentralized agency.

(3)(a) The central office shall establish departmental policies, rules, procedures, and standards and shall monitor the implementation of such policies, rules, procedures, and standards in order to ensure uniform compliance and quality performance by the districts and central office units that implement transportation programs. Major transportation policy initiatives or revisions shall be submitted to the commission for review.

Section 334.044, F.S. Department; powers and duties. The department shall have the following general powers and duties:

(10)(a) To develop and adopt uniform minimum standards and criteria for the design, construction, maintenance, and operation of public roads pursuant to the provisions of Section, 336.045, **F.S.**

Section 336.045, F.S. Uniform minimum standards for design, construction, and maintenance; advisory committees.

(1) The department shall develop and adopt uniform minimum standards and criteria for the design, construction, and maintenance of all public streets, roads, highways, bridges, sidewalks, curbs and curb ramps, crosswalks, where feasible, bicycle ways, underpasses and overpasses used by the public for vehicular and pedestrian traffic. In developing such standards and criteria, the department shall consider design approaches which provide for the compatibility of such facilities with the surrounding natural or manmade environment; the safety and security of public spaces; and the appropriate aesthetics based upon scale, color, architectural style, materials used to construct the facilities, and the landscape

design and landscape materials around the facilities.

(2) An advisory committee of professional engineers employed by any city or any county in each transportation district to aid in the development of such standards shall be appointed by the head of the department. Such committee shall be composed of: one member representing an urban center within each district; one member representing a rural area within each district; one member within each district who is a professional engineer and who is not employed by any governmental agency; and one member employed by the department for each district.

(4) All design and construction plans for projects that are to become part of the county road system and are required to conform with the design and construction standards established pursuant to subsection (1) must be certified to be in substantial conformance with the standards established pursuant to subsection (1) that are then in effect by a professional engineer who is registered in this state.

These standards are intended to provide basic guidance for developing and maintaining a highway system with reasonable operating characteristics and a minimum number of hazards.

Standards established by this Manual are intended for use on all streets and highways off the State Highway System (SHS). Certain projects off the SHS but on the National Highway System (NHS) utilizing federal funds may be required to follow additional design criteria. Please see **Chapter 19** of the Department's **Local Agency Program Manual** for further information. Information on roadways included in the NHS is found at the Department's Transportation Statistics Office website: **National Highway System Maps.**

Standards are provided for the design of new and resurfacing construction and reconstruction projects as well as maintenance and resurfacing projects. off the state highway and federal aid systems. Unless specified otherwise herein, It is understood that existing streets and highways may not conform to all minimum standards applicable to the design of new and standards herein cannot be applied completely to all reconstruction and maintenance type projects. For existing roads not being replaced or reconstructed, it is intended that the requirements provided in **Chapter 10 – Maintenance and Resurfacing** are applied. For all projects, there may be practical reasons a certain standard is not met. A process is provided in **Chapter 14 – Design Exceptions** to address those situations. However, the standards shall be applied to reconstruction and maintenance projects to the extent state or federal statute requires and that economic and environmental considerations and existing development will allow.

When this Manual refers to guidelines and design standards given by current American Association of State Highway and Transportation Officials (AASHTO) publications, these guidelines and standards shall generally be considered as minimum criteria. The Department may have standards and criteria that differ from the minimum presented in this Manual or by AASHTO for streets and highways under its jurisdiction. A county or municipality may substitute standards and criteria adopted by the Department for some or all portions of design, construction, and maintenance of their facilities. Department standards, criteria, and manuals must be used when preparing projects on the state highway system or the national highway system.

Criteria and standards set forth in other manuals, which have been incorporated by reference, shall be considered as requirements within the authority of this Manual.

This Manual is intended for use by qualified engineering practitioners for the communication of standards and criteria (including various numerical design values and use conditions). The design, construction, and maintenance references for the infrastructure features contained in this Manual recognize many variable and often complex process considerations. The engineering design process, and associated use of this Manual, incorporates aspects of engineering judgment, design principles, science, and recognized standards towards matters involving roadway infrastructure.

Users of this Manual are cautioned that the strict application of exact numerical values, conditions or use information taken from portions of the text may not be appropriate for all circumstances. Individual references to design values or concepts should not be used out of context or without supporting engineering judgment.

The contents of this Manual are reviewed annually by the Florida "Greenbook" Advisory Committee. Membership of this committee is established by the above referenced Section 336.045(2), F.S. Comments, suggestions, or questions may be directed to any committee member.

THIS PAGE INTENTIONALLY LEFT BLANK

POLICY

Specific policies governing the activities of planning, design, construction, reconstruction, maintenance, or operation of streets and highways are listed throughout this Manual. All agencies and individuals involved in these activities shall be governed by the following general policies:

- Each public street and highway, and all activities thereon, shall be assigned to the jurisdiction of some highway agency. Each highway agency should establish and maintain a program to promote safety in all activities on streets and highways under its jurisdiction.
- Highway safety shall be considered and given a high priority in order to promote the achievement of the maximum safety benefits for given expenditures and efforts.
- The provision for safe, high-quality streets and highways, and maximum transit opportunities should take priority over the provision for the maximum highway mileage obtainable for the available funds.

OBJECTIVES

The planning, design, construction, reconstruction, maintenance, and operation of streets and highways should be predicated upon meeting the following objectives:

- Develop and maintain a highway system that provides the safest practicable environment for motorists, cyclists, pedestrians, and workers.
- Establish and maintain procedures for construction, maintenance, utility, and emergency operations that provide for safe highway and transit operating conditions during these activities.
- Provide streets and highways with operating characteristics that allow for reasonable limitations upon the capabilities of vehicles, drivers, cyclists, pedestrians, and workers.
- Provide uniformity and consistency in the design and operation of streets and highways.

- Provide for satisfactory resolution of conflicts between the surface transportation system and social and environmental considerations to aid neighborhood integrity.
- Reconstruct or modify existing facilities to reduce the hazard to the highway users.
- Reduce the deaths, injuries, and damage due to highway crashes.

Additional general and specific objectives related to various topics and activities are listed throughout this Manual. Where specific standards or recommendations are not available or applicable, the related objectives shall be utilized as general guidelines.

DEFINITIONS OF TERMS

The following terms shall, for the purpose of this Manual, have the meanings respectively ascribed to them, except instances where the context clearly indicates a different meaning. The [Manual of Uniform Traffic Control Devices \(2009 Edition with Revision Numbers 1 and 2, May 2012, MUTCD\)](#) includes additional information on terms used in conjunction with the application of the **MUTCD**.

Alley	A narrow right of way to provide access to the side or rear of individual land parcels.
Annual Average Daily Traffic (AADT)	The total volume of traffic on a highway segment for one year, divided by the number of days in the year. This volume is usually estimated by adjusting a short-term traffic count with weekly and monthly factors.
Average Daily Traffic (ADT)	The total traffic volume during a given time period (more than a day, less than a year) divided by the number of days in that time period.
Auxiliary Lane	A designated width of roadway pavement marked to separate speed change, turning, passing, and climbing maneuvers from through traffic.
Average Running Speed	For all traffic, or component thereof, the summation of distances divided by the summation of running times.
Bicycle Lane (Bike Lane)	A portion of a roadway that has been designated for preferential use by bicyclists by pavement markings, and if used, signs. They are one-way facilities that typically carry traffic in the same direction as adjacent motor vehicle traffic.

**Boarding And Alighting (B&A)
Area**

A Firm, Stable, Slip Resistant Surface That accommodates passenger movement on or off a transit vehicle.

Border Area^[KM2]

The border area provides space for roadside design components (e.g., signing, drainage features, sidewalks, and traffic control devices), a buffer between vehicles and pedestrians, and permitted public utilities. It also provides space for construction and maintenance of the facility.

Clear Zone

The unobstructed, traversable area beyond the edge of the traveled way for the recovery of errant vehicles. The clear zone includes shoulders and bicycle lanes. The roadside border area, starting at the edge of the traveled way, available for safe use by errant vehicles. This area may consist of a shoulder, recoverable slope, non-recoverable slope, clear runoff area, or combination thereof. The desired width is dependent upon the traffic volumes and speeds, and on the roadside geometry. Note: The aforementioned "border area" is not the same as "border width". Also, see Horizontal Clearance.

Corridor

A strip of land between two termini within which traffic, topography, environment, population, access management, and other characteristics are evaluated for transportation purposes.

Crosswalk

Portion of the roadway at an intersection included within the connections of lateral lines of the sidewalks on opposite sides of the highway, measured from the curbs or in the absence of curbs from the traversable roadway. Crosswalks may also occur at an intersection or elsewhere distinctly indicated for pedestrian crossing.

Design Hour Volume (DHV)

Traffic volume expected to use a highway segment during the design hour of the design year. The DHV is related to the AADT by the “K” factor. It includes total traffic in both directions of travel.

Directional Design Hour Volume (DDHV)

Traffic volume expected to use a highway segment during the design hour of the design year in the peak direction.

Design Speed

A selected speed used to determine the various geometric design features of the roadway. The selected design speed should be a logical one with respect to the topography, anticipated operating speed, adjacent land use, and functional classification of the highway.

Design Vehicle

A vehicle, with representative weight, dimensions, and operating characteristics, used to establish highway design controls for accommodating vehicles of designated classes.

Driveway

An access from a public way to adjacent property.

Expressway

A divided arterial highway for through traffic with full or partial control of access and generally with grade separations at major intersections.

Federal Aid Highway

A highway eligible for assistance under the United States Code Title 23 other than a highway classified as a local road or rural minor collector.

Freeway or Limited Access Highway

An expressway with full control of access.

Frontage Road or Street

A street or highway constructed adjacent to a higher classification street or other roadway network for the purpose of serving adjacent property or control access.

Grade Separation

A crossing of two roadways or a roadway and a railroad or pedestrian pathway at different levels.

High Speed

Speeds of 50 mph or greater.

High-Speed Rail

Intercity passenger rail service that is reasonably expected to reach speeds of at least 110 miles per hour.

Highway, Street, or Road

General terms, denoting a public way for purposes of traffic, both vehicular and pedestrian, including the entire area within the right of way. The term street is generally used for urban or suburban areas.

~~**Horizontal Clearance**~~

~~Lateral distance from edge of motor vehicle travel lane to a roadside object or feature.~~

Intersection

The general area where two or more streets or highways join or cross.

Lateral Offset

The lateral distance from the edge of the traveled way or when applicable, face of curb, to a roadside object or feature.

May

A permissive condition. Where "may" is used, it is considered to denote permissive usage.

Maintenance

A strategy of treatments to an existing roadway system that preserves it, retards future deterioration, and maintains or improves the functional condition.

New Construction

The construction of any public way (paved or unpaved) where none previously existed, or the act of paving any previously unpaved road, except as provided in Chapter 3, Section A of these standards.

Operating Speed

The rate of travel at which vehicles are observed traveling during free-flow conditions.

Paratransit

Comparable transportation service required by the ADA for individuals with disabilities who are unable to use fixed route transportation systems.

Pedestrian Access Route

A continuous and unobstructed path of travel provided for pedestrians with disabilities within or coinciding with a pedestrian circulation path.

Pedestrian Circulation Path

A prepared exterior or interior surface provided for pedestrian travel in the public right-of-way.

Preferential Lane

A street or highway lane reserved for the exclusive use of one or more specific types of vehicles or vehicles with at least a specific number of occupants.

Public Way

All public streets, roads, highways, bridges, sidewalks, curbs and curb ramps, crosswalks (where feasible), bicycle facilities, underpasses, and overpasses used by the public for vehicular and pedestrian traffic.

Ramp

1) Includes all types, arrangements, and sizes of turning roadways that connect two or more legs at an interchange. 2) A combined ramp and landing to accomplish a change in level at a curb (curb ramp).

Reconstruction

~~Any road construction other than new construction.~~ Reconstruction is defined as streets and highways that are rebuilt primarily along existing alignment. Reconstruction normally involves full-depth pavement replacement. Other work that would fall into the category of reconstruction would be adding lanes adjacent to an existing alignment, changing the fundamental character of the roadway (e.g., converting a two-lane highway to a multi-lane divided arterial) or reconfiguring intersections and interchanges.

Recovery Area

A clear zone that includes the total roadside border area, starting at the edge of the traveled way, available for safe use by errant vehicles.

Residential Streets

Streets primarily serving residential access to the commercial, social, and recreational needs of the community. These are generally lower volume and lower speed facilities than the primary arterial and collector routes of the local system "or as adopted by local government ordinance".

Resurfacing

Work to place additional layers of surfacing on highway pavement, shoulders, bridge decks, and necessary incidental work to extend the structural integrity of these features for a substantial time period.

Right of Way

A general term denoting land, property or interest therein, usually in a strip, acquired or donated for transportation purposes. More specifically, land in which the State, the Department, a county, a transit authority, municipality, or special district owns the fee or has an easement devoted to or required for use as a public road.

Roadway	The portion of a street or highway, including shoulders, for vehicular use. A divided highway has two or more roadways.
Rural Areas	Those areas outside of urban boundaries. Urban area boundary maps based upon the 2010 Census are located on the Department's Urban Area 1-Mile Buffer Maps .
Shall or Must	A mandatory condition. (When certain requirements are described with the "shall" or "must" stipulation, it is mandatory these requirements be met.)
Shared Street	Specially designed residential or commercial street where space is shared by all users and alignment supports slower vehicle speeds and the perception of shared space.
Shared Roadway	A roadway that is open to both bicycle and motor vehicle travel. This may be an existing roadway, street with wide curb lanes, or road with paved shoulders.
Shared Use Path <u>or Multi - Use Trail</u>	Paved facilities physically separated from motorized vehicular traffic by an open space or barrier. May be within the highway right of way or an independent right of way, with minimal cross flow by motor vehicles. Users are non-motorized and may include: pedestrians, bicyclists, skaters, people with disabilities, and others.
Should	An advisory condition. Where the word "should" is used, it is considered to denote advisable usage, recommended but not mandatory.

Slope

The relative steepness of the terrain, expressed as a ratio or percentage. Slopes may be categorized as positive (backslopes) or negative (foreslopes) and as parallel or cross slopes in relation to the direction of traffic. In this manual slope is expressed as a ratio of vertical to horizontal (V:H).

Surface Transportation System

Network of highways, streets, and/or roads. Term can be applied to local system or expanded to desired limits of influence.

Traditional Neighborhood Development (TND)

TND refers to the development or redevelopment of a neighborhood or town using traditional town planning principles. Projects should include a range of housing types and commercial establishments, a network of well-connected streets and blocks, civic buildings and public spaces, and include other uses such as stores, schools, and places of worship within walking distances of residences.

Traffic

Pedestrians, bicyclists, motor vehicles, streetcars and other conveyances either singularly or together while using for purposes of travel any highway or private road open to public travel.

Traffic Lane

Includes travel lanes, auxiliary lanes, turn lanes, weaving, passing, and climbing lanes.

Travel Lane

A designated width of roadway pavement marked to carry through traffic and to separate it from opposing traffic or traffic occupying other traffic lanes. Generally, travel lanes equate to the basic number of lanes for a facility.

Traveled Way

The portion of the roadway for the movement of vehicles, exclusive of shoulders, berms, sidewalks and parking lanes.

Turning Roadway

A connecting roadway for traffic turning between two intersection legs.

Urban Area

A geographic region comprising as a minimum the area inside the United States Bureau of the Census boundary of an urban place with a population of 5,000 or more persons, expanded to include adjacent developed areas as provided for by Federal Highway Administration ([FHWA](#)) regulations. Urban area boundary maps based upon the 2010 Census are located on the [Department's Urban Area 1-Mile Buffer Maps](#).

Urbanized Area

A geographic region comprising as a minimum the area inside an urban place of 50,000 or more persons, as designated by the United States Bureau of the Census, expanded to include adjacent developed areas as provided for by Federal Highway Administration ([FHWA](#)) regulations. Urban areas with a population of fewer than 50,000 persons which are located within the expanded boundary of an urbanized area are not separately recognized.

Vehicle

Every device upon, or by which any person or property is or may be transported or drawn upon a traveled way, excepting devices used exclusively upon stationary rails or tracks. Bicycles are defined as vehicles per Section 316.003, Florida Statutes.

Vertical Clearance

Minimum unobstructed vertical passage space.

Very Low-Volume Road

A road that is functionally classified as a local road and has a design average daily traffic volume of 400 vehicles per day or less.

Wide Outside Lane

Through lanes that provide a minimum of 14' in width. This lane should always be the through lane closest to the curb or shoulder of the road when a curb is not provided.

CHAPTER 4

ROADSIDE DESIGN

A	INTRODUCTION	4-1
B	ROADSIDE TOPOGRAPHY AND DRAINAGE FEATURES	4-3
B.1	Roadside Slopes, Clear Zone and Lateral Offset	4-3
B.1.a	Roadside Slopes and Clear Zone	4-3
B.1.b	Lateral Offset	4-8
B.2	Drainage Features	4-10
B.2.a	Roadside Ditches	4-11
B.2.b	Drainage Structures	4-11
B.2.c	Canals and Water Bodies	4-11
B.2.d	Curb	4-15
C	ROADSIDE SAFETY FEATURES AND CRASH TEST CRITERIA	4-17
C.1	Crash Test Criteria	4-17
C.2	Safety Hardware Upgrades	4-21
D	SIGNS, SIGNALS, LIGHTING SUPPORTS, UTILITY POLES, TREES AND SIMILAR ROADSIDE FEATURES	4-23
D.1	General	4-23
D.2	Performance Requirements for Breakaway Devices	4-23
D.3	Sign Supports	4-23
D.4	Traffic Signal Supports	4-24
D.5	Lighting Supports	4-24
D.5.a	Conventional Lighting	4-24
D.5.b	High Mast Lighting	4-25
D.6	Utility Poles	4-25
D.7	Trees	4-26
D.8	Miscellaneous	4-26
D.8.a	Fire Hydrants	4-26
D.8.b	Railroad Crossing Warning Devices	4-26
D.8.c	Mailbox Supports	4-26

	<u>D.8.d</u>	<u>Bus Benches and Shelters.....</u>	<u>4-29</u>		
<u>E</u>		<u>BARRIERS, END TREATMENTS AND CRASH CUSHIONS.....</u>	<u>4-37</u>		
	<u>E.1</u>	<u>Roadside Barriers</u>	<u>4-37</u>		
	<u>E.2</u>	<u>End Treatments</u>	<u>4-40</u>		
	<u>E.3</u>	<u>Crash Cushions</u>	<u>4-42</u>		
	<u>E.4</u>	<u>Performance Requirements</u>	<u>4-42</u>		
	<u>E.5</u>	<u>Warrants</u>	<u>4-42</u>		
		<u>E.5.a</u>	<u>Above Ground Hazards</u>	<u>4-43</u>	
		<u>E.5.b</u>	<u>Drop-Off Hazards.....</u>	<u>4-43</u>	
		<u>E.5.c</u>	<u>Canals and Water Bodies</u>	<u>4-43</u>	
		<u>E.5.d</u>	<u>Medians</u>	<u>4-43</u>	
		<u>E.5.e</u>	<u>Work Zones.....</u>	<u>4-43</u>	
	<u>E.6</u>	<u>Barrier Types</u>	<u>4-45</u>		
		<u>E.6.a</u>	<u>Guardrail</u>	<u>4-45</u>	
		<u>E.6.b</u>	<u>Concrete Barrier.....</u>	<u>4-46</u>	
		<u>E.6.c</u>	<u>High Tension Cable Barrier.....</u>	<u>4-47</u>	
		<u>E.6.d</u>	<u>Temporary Barrier</u>	<u>4-48</u>	
		<u>E.6.e</u>	<u>Selection Guidelines</u>	<u>4-49</u>	
		<u>E.6.f</u>	<u>Placement.....</u>	<u>4-49</u>	
			<u>E.6.f.1</u>	<u>Barrier Offsets</u>	<u>4-49</u>
			<u>E.6.f.2</u>	<u>Deflection Space and Zone of Intrusion</u>	<u>4-51</u>
			<u>E.6.f.3</u>	<u>Grading</u>	<u>4-53</u>
			<u>E.6.f.4</u>	<u>Curbs.....</u>	<u>4-54</u>
			<u>E.6.f.5</u>	<u>Flare Rate</u>	<u>4-54</u>
			<u>E.6.f.6</u>	<u>Length of Need.....</u>	<u>4-55</u>
		<u>E.6.g</u>	<u>Barrier Transitions.....</u>	<u>4-55</u>	
		<u>E.6.h</u>	<u>Attachments to Barriers</u>	<u>4-55</u>	
	<u>E.7</u>	<u>End Treatments and Crash Cushions</u>	<u>4-56</u>		
		<u>E.7.a</u>	<u>End Treatments for Guardrail.....</u>	<u>4-56</u>	
		<u>E.7.b</u>	<u>End Treatments for Rigid Barrier</u>	<u>4-57</u>	
		<u>E.7.c</u>	<u>End Treatments for High Tension Cable Barrier</u>	<u>4-57</u>	
		<u>E.7.d</u>	<u>End Treatments for Temporary Barrier</u>	<u>4-57</u>	
		<u>E.7.e</u>	<u>Crash Cushions</u>	<u>4-57</u>	

F	BRIDGE RAILS	4-58
G	REFERENCES	4-59
A	INTRODUCTION	4-1
B	POLICY 4-1	
C	OBJECTIVES	4-2
D	ROADSIDE DESIGN	4-3
D.1	Geometric Changes	4-3
D.1.a	Horizontal Curves	4-3
D.1.b	Vertical Curves	4-4
D.1.c	Changes in Cross Section	4-4
D.1.d	Decision or Conflict Points	4-4
D.2	Fills	4-4
D.3	Cuts	4-4
D.4	Roadside Canals	4-5
D.5	Vegetation	4-5
D.5.a	Stability	4-6
D.5.b	Drainage	4-6
D.5.c	Environmental and Aesthetic Considerations	4-6
D.5.d	Landscaping – Design Considerations	4-6
D.6	Drainage	4-7
D.6.a	Inlets	4-7
D.6.b	Ditches	4-7
D.6.c	Culverts	4-8
D.7	Curbs	4-8
D.8	Poles and Support Structures	4-9
D.9	Intersections	4-10
D.10	Underpasses	4-10
D.11	Bridges and Overpasses	4-10
D.12	Mailboxes	4-11
D.13	Bus Shelters	4-11
E	PROTECTIVE DEVICES	4-12

E.1	Redirection Devices	4-12
E.1.a	Function	4-12
E.1.b	Warranting Conditions	4-12
E.1.c	Location	4-13
E.1.d	Length	4-13
E.1.e	Vehicle Containment	4-13
E.1.f	Barrier Types	4-13
E.1.g	Transitions	4-14
E.1.h	Terminations	4-14
E.2	Energy Absorbing Devices	4-14
E.2.a	Function	4-14
E.2.b	Warranting Conditions	4-15
E.2.c	Design Criteria	4-15
E.2.d	Design Details	4-15
F	REFERENCES FOR INFORMATIONAL PURPOSES	4-17

TABLES

Table 4 – 1	Minimum Width of Clear Zone (feet)	4-5
Table 4 – 2	Lateral Offset (feet)	4-10
Table 4 – 3	Test Levels for Barriers, End Terminals, Crash Cushions.....	4-19
Table 4 – 4	Test Levels for Breakaway Devices, Work Zone Traffic Control Devices	4-20
Table 4 – 5	Clear Zone Width Requirements for Work Zones	4-44
Table 4 – 6	Minimum Barrier Setback (Measured from the face of the barrier)	4-52

FIGURES

Figure 4 – 1	Clear Zone Plan View	4-6
Figure 4 – 2	Basic Clear Zone Concept	4-6

<u>Figure 4 – 3</u>	<u>Adjusted Clear Zone Concept.....</u>	<u>4-6</u>
<u>Figure 4 – 4</u>	<u>Roadside Ditches – Bottom Width 0 to < 4 Feet</u>	<u>4-7</u>
<u>Figure 4 – 5</u>	<u>Roadside Ditches – Bottom Width ≥ 4 Feet</u>	<u>4-8</u>
<u>Figure 4 – 6</u>	<u>Minimum Offsets for Canal Hazards Rural and Urban Flush Shoulders</u>	<u>4-14</u>
<u>Figure 4 – 7</u>	<u>Minimum Offsets for Canal Hazards Urban Curb or Curb and Gutter</u>	<u>4-15</u>
<u>Figure 4 – 8</u>	<u>Sidewalk with Guardrail.....</u>	<u>4-50</u>
<u>Figure 4 – 9</u>	<u>Setback Distances for Discontinuous Elements.....</u>	<u>4-53</u>

CHAPTER 4

ROADSIDE DESIGN

A INTRODUCTION

This chapter presents guidelines and standards for roadside designs intended to reduce the likelihood and/or consequences of roadside crashes. Due to the variety of causative factors, the designer should review crash reports for vehicles leaving the traveled way at any location. Between 2011 and 2015, lane departure crashes in Florida represented approximately 35 percent of all crashes and approximately 44 percent of all highway fatalities. Construction and maintenance of safe medians and roadsides are of vital importance in the development of safe streets and highways. Design of the roadside should be based upon reducing the consequences to errant vehicles and their occupants.

Many of the standards presented in **Chapter 3 - Geometric Design** are predicated to a large extent upon reducing the probability of vehicles leaving the proper travel path. Other standards in that chapter are directed toward a reduction in the likelihood and/or consequences of crashes by vehicles leaving the roadway—, such as shoulders and medians. These standards contain requirements for the design of shoulders, medians, and roadsides including requirements for the use of longitudinal barriers. The dDesign of the roadside beyond the shoulder should also be considered and conducted as an integral part of the total highway design.

~~Due to the variety of causative factors, the designer should consider a vehicle leaving the traveled way at any location. Design of the roadside should be based upon reducing the consequences to errant vehicles and their occupants.~~

The general objective of roadside design is to provide an environment that will reduce the likelihood and/or consequences of crashes by vehicles that have left the traveled way. The achievement of this general objective will be aided by the following:

- Roadside areas adequate to allow reasonable space and time for a driver to regain or retain control of the vehicle and stop or return to the traveled way safely.
- Shoulders, medians, and roadsides that may be traversed safely without vehicle vaulting or overturning.
- Location of roadside fixed objects and hazards as far from the travel lane as is economically feasible.

- Roadsides that accommodate necessary maintenance vehicles, emergency maneuvers and emergency parking.
- Protection of pedestrians, workers, or other persons subjected to the hazard of errant vehicles.
- Provide adequate shielding of hazards where appropriate and compatible with vehicle speeds and other design variables.

Prior to any other consideration, the designer should, in order of preference, attempt to:

1. Eliminate the hazard
 - a. Remove the hazard
 - b. Redesign the hazard so it can be safely traversed
 - c. Relocate the hazard outside the clear zone
2. Make the hazard crashworthy
3. Shield the hazard with a longitudinal barrier or crash cushion.
4. Delineate the hazard and leave the hazard unshielded. This treatment is taken only when the barrier or crash cushion is more hazardous than the hazard. See Section E.5 for information on making this determination.

This chapter contains standards and general guidelines for particular situations encountered in roadside design due to the variety and complexity of possible situations encountered. In addressing roadside hazards, the designer should utilize the following as basic guidelines to develop a safe roadside design.

B **ROADSIDE TOPOGRAPHY AND DRAINAGE FEATURES** **POLICY**

B.1 Roadside Slopes, Clear Zone and Lateral Offset

Providing a sufficient amount of recoverable slope or clear zone adjacent to the roadway, free of obstacles and hazards provides an opportunity for an errant vehicle to safely recover. Minimum standards for roadside slopes, clear zone and lateral offsets to hazards are provided as follows.

B.1.a Roadside Slopes and Clear Zone

The slopes of all roadsides should be as flat as possible to allow for safe traversal by out of control vehicles. A slope of 1:4 or flatter should be used, desirably 1:6 or flatter. The transition between the shoulder and adjacent side slope should be rounded and free from discontinuities. A slope as steep as 1:3 may be used within the clear zone if the clear zone width is adjusted to provide a clear runout area as described below. If sufficient right of way exists, use flatter side slopes on the outside of horizontal curves.

Clear zone is the unobstructed, traversable area beyond the edge of the traveled way for the recovery of errant vehicles. The clear zone includes shoulders and bicycle lanes. The clear zone must be free of aboveground fixed objects, water bodies and non-traversable or critical slopes. Clear zone width requirements are dependent on AADT, design speed, and roadside slope conditions. With regard to the ability of an errant vehicle to traverse a roadside slope, slopes are classified as follows:

1. Recoverable Slope – Traversable Slope 1:4 or flatter. Motorists who encroach on recoverable foreslopes generally can stop their vehicles or slow them enough to return to the roadway safely.
2. Non-Recoverable Slope – Traversable Slope steeper than 1:4 and flatter than 1:3. Non-recoverable foreslopes are traversable but most vehicles will not be able to stop or return to the roadway easily. Vehicles on such slopes typically can be expected to reach the bottom.
3. Critical Slope – Non-Traversable Slope steeper than 1:3. A critical foreslope is one on which an errant vehicle has a higher propensity to overturn.

Clear zone widths for recoverable foreslopes 1V:4H and flatter are provided in Table 4 – 1 Minimum Width of Clear Zone. Clear zone is applied as shown in Figures 4 – 1 Clear Zone Plan View and 4 – 2 Basic Clear Zone Concept^(KM1).

On non-recoverable slopes steeper than 1:4 and flatter than 1:3, a high percentage of encroaching vehicles will reach the toe of these slopes. Therefore, the clear zone distance cannot logically end at the toe of a non-recoverable slope. When such non-recoverable slopes are present within the clear zone width provided in Table 4 – 1, additional clear zone width is required. The minimum amount of additional width provided must equal the width of the non-recoverable slope with no less than 10 feet of recoverable slope provided at the toe of the non-recoverable slope. See Figure 4 – 3 Adjusted Clear Zone Concept.

When clear zone requirements cannot be met, see Sections C, D and E for requirements for roadside barriers and other treatments for safe roadside design. In addition, the Department's *Plans Preparation Manual (PPM)*, *AASHTO Roadside Design Guide (2011)*, and *AASHTO Guidelines for Geometric Design of Very Low Volume Local Roads (ADT ≤ 400) (2001)* may be referenced for a more thorough discussion of roadside design.

Table 4 – 1 Minimum Width of Clear Zone^{[KM2][KM3]} (feet)

Design Speed mph	AADT ≥ 1500			AADT < 1500 ¹		
	Travel Lanes & Multilane Ramps		Aux Lanes and Single Lane Ramps	Travel Lanes & Multilane Ramps		Aux Lanes and Single Lane Ramps
	1V:6H or flatter	1V:5H to 1V:4H	1V:4H or flatter	1V:6H or flatter	1V:5H to 1V:4H	1V:4H or flatter
≤ 40	14	16	10	10 ²	12 ²	10 ²
45 – 50	20	24	14	14	16	14
55	22	26	18	16	20	14
60	30	30 ³	24	20	26	18
65 – 70	30	30 ³	24	24	28	18

1. Clear Zone for roads functionally classified as Local Roads with a design AADT ≤ 400 vehicles per day^{[KM4][KM5]}:
 - a. A clear zone of 6 feet or more in width must be provided if it can be done so with minimum social/environmental impacts.
 - b. Where constraints of cost, terrain, right of way, or potential social/environmental impacts make the provision of a 6 feet clear zone impractical, clear zones less than 6 feet in width may be used, including designs with 0 feet clear zone.
 - c. In all cases, clear zone must be tailored to site-specific conditions, considering cost-effectiveness and safety tradeoffs. The use of adjustable clear zone widths, such as wider clear zone dimensions at sharp horizontal curves where there is a history of run-off-road crashes, or where there is evidence of vehicle encroachments such as scarring of trees or utility poles, may be appropriate. Lesser values of clear zone width may be appropriate on tangent sections of the same roadway.
 - d. Other factors for consideration in analyzing the need for providing clear zones include the crash history, the expectation for future traffic volume growth on the facility, and the presence of vehicles wider than 8.5 feet and vehicles with wide loads, such as farm equipment.
2. May be reduced to 7 feet for a design AADT < 750 vehicles per day.
3. Greater clear zone widths provide additional safety for higher speed and volume roads. See Section 3.1 of the AASHTO Roadside Design Guide for further information.

The roadside, which includes the median, shall be considered as the total environment adjacent to the roadway. The design of the roadside shall be considered as an integral part of the total highway design.

Figure 4 – 1 Clear Zone Plan View

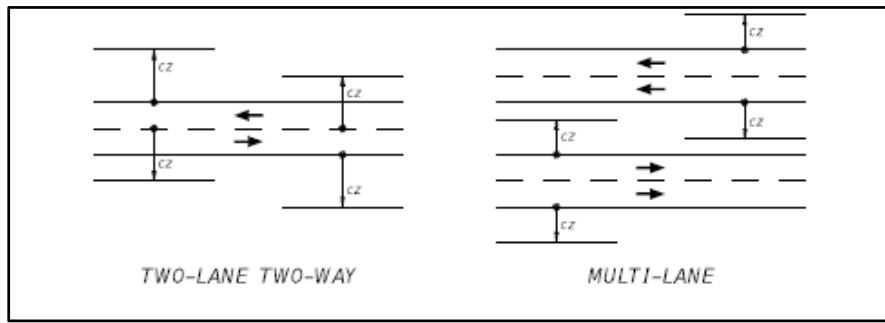

Figure 4 – 2 Basic Clear Zone Concept

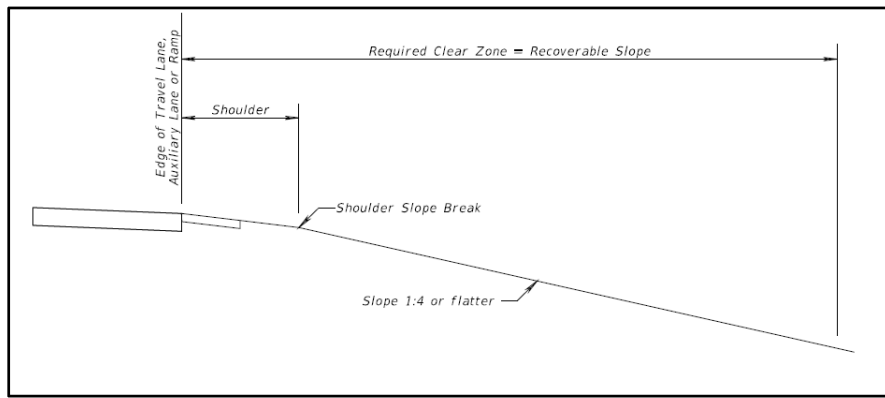
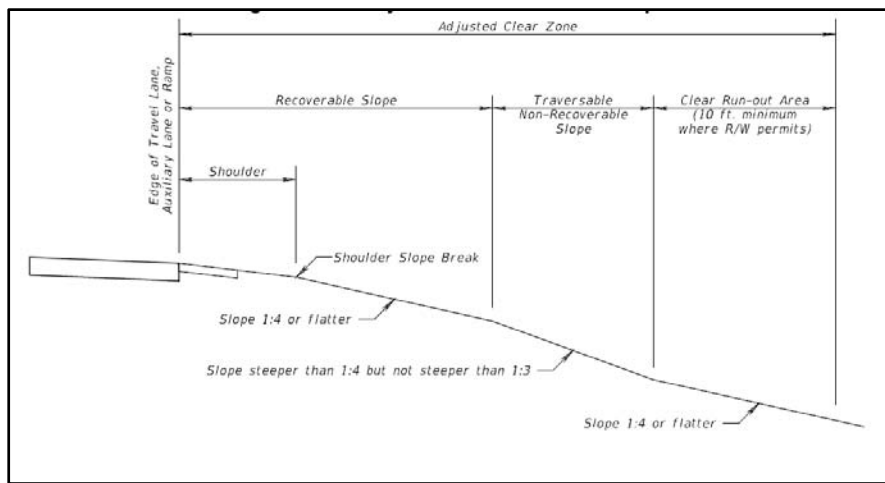
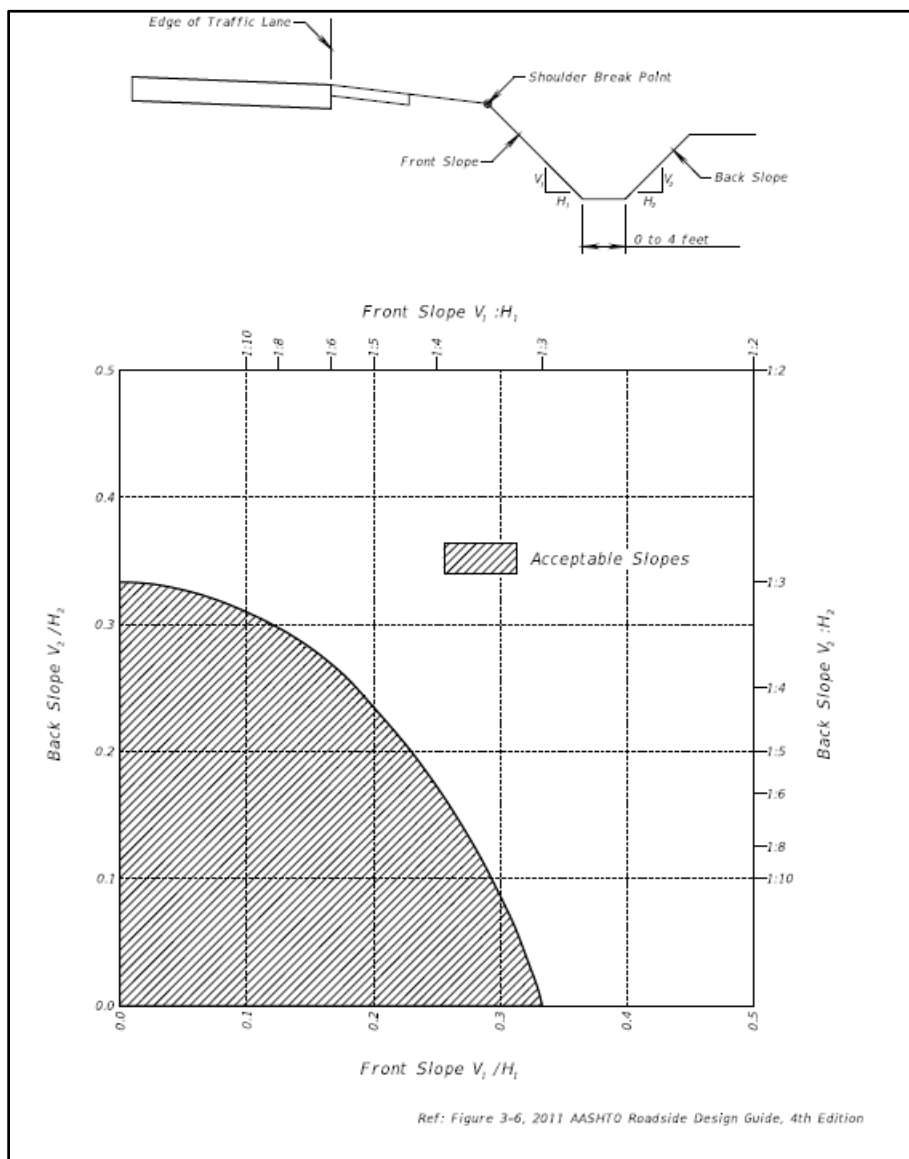

Figure 4 – 3 Adjusted Clear Zone Concept



Roadside ditches may be included within the clear zone if properly designed to be traversable. Acceptable cross section slope criteria for roadside ditches within the clear zone is provided in Figure 4 – 4 Roadside Ditches – Bottom Width 0 to < 4 Feet and Figure 4 – 5 Roadside Ditches – Bottom Width \geq 4 Feet. These roadside ditch configurations are considered traversable.

Figure 4 – 4 Roadside Ditches – Bottom Width 0 to < 4 Feet (KM6)



- Design speed,
- Location; i.e. rural areas or within urban boundary,
- Flush shoulder or with curb,
- Traffic volumes, and
- Lane type; e.g. travel lanes, auxiliary lanes, and ramps.

Lateral Offset requirements are provided in Table 4 – 2.

Flush shoulder roadways typically have sufficient right of way to provide the required clear zone widths. Therefore, lateral offset requirements for these type roadway are based on providing the clear zone widths provided in Table 4 – 1.

On urban curbed roadways with design speeds \leq 45 mph, lateral offsets based on Table 4 – 1 clear zone requirements should be provided where practical. However, these urban low speed roads are typically located in areas where right of way is restricted (characterized by more dense abutting development, presence of parking, closer spaced intersections and accesses to property, and more bicyclists and pedestrians). The available right of way is typically insufficient to provide the required clear zone widths. Therefore, lateral offset requirements for above ground objects on these roadways are based on offsets needed for normal operation and not on maintaining a clear roadside for errant vehicles.

Table 4 – 2 Lateral Offset (feet)

<u>Roadside Feature</u>	<u>Urban Curbed Roadways Design Speed ≤ 45 (mph)</u>	<u>All Other</u>
<u>Above Ground Objects¹</u>	<u>4 ft. from Face of Curb²[KM7]</u>	<u>Clear Zone Width</u>
<u>Drop Off Hazards³</u>	<u>Clear Zone Width</u>	<u>Clear Zone Width</u>
<u>Water Bodies</u>	<u>Clear Zone Width</u>	<u>Clear Zone [Width][KM8]</u>
<u>Canal Hazards</u>	<u>See Section B.2.c</u>	<u>See Section B.2.c</u>

1. Above ground objects are anything greater than 4 inches in height and are firm and unyielding or do not meet crashworthy or breakaway criteria. For urban curbed areas ≤ 45 mph this also includes crashworthy or breakaway objects except those necessary for the safe operation of the roadway.

2. May be reduced to 1.5 ft. from Face of Curb on roads functionally classified as Local Streets and on all roads where the 4 ft. minimum offset cannot be reasonably obtained and other alternatives are deemed impractical.

3. Drop off hazards are:

- a. Any vertical faced structure with a drop off (e.g. retaining wall, wing-wall, etc.) located within the Clear Zone.
- b. Slopes steeper than 1:3 located within the Clear Zone.
- c. Drop-offs with significant crash history.

B.2 Drainage Features

Drainage design is an important aspect of the long-term performance of a roadway, and to achieve an effective design, drainage features are necessary in close proximity to travel lanes. These features include ditches, curbs, and drainage structures (e.g. transverse/parallel pipes, culverts, endwalls, wingwalls, and inlets). The placement of these features are to be evaluated as part of roadside safety design. Refer to **Chapter 20 – Drainage** for information regarding proper hydraulic design.

When evaluating the design of roadside topography and drainage features, consider the future maintenance implications of the facility. Routine maintenance or repairs needed to ensure the continued function of the roadway slopes or

drainage may lead to long-term expenses and activities, which disrupts traffic flow and exposes maintenance personnel to traffic conditions.

B.2.a Roadside Ditches

Minimum standards for side slopes and bottom widths of roadside ditches and channels within the clear zone are provided in Section B.1.a.

B.2.b Drainage Structures^[KM9]

Drainage structures and their associated end treatments located along the roadside should be implemented using either a traversable design or located outside the required clear zone. The various drainage inlets and pipe end treatments needed for an efficient drainage design typically contain curb inlets, ditch bottom inlets, endwalls, wingwalls, headwalls, flared end sections and/or mitered end sections. If not adequately designed or properly located, these features can create hazardous conditions (e.g. abrupt deceleration or rollovers) for vehicles. For detailed background information concerning traversable designs, refer to the ***AASHTO Roadside Design Guide***.

Standard details for drainage structures and end treatments commonly used in Florida are provided the in the Department's ***Design Standards Index 200 Series***. Drainage features shown in the Department's ***Design Standards*** have the potential for conflict with a vehicle either departing the roadway or within a commonly traversed section of a roadway. The department's ***Drainage Manual*** identifies those standard drainage structures which are acceptable for use within the clear zone.

B.2.c Canals and Water Bodies

Wording as currently written in 2016 rule making:

~~Roadside canals or other bodies of water close to the roadway should be eliminated wherever feasible. A canal is defined as an open ditch parallel to the roadway for a minimum distance of 1000 ft. and with a seasonal water depth in excess of 3 ft. for extended periods of time (24 hours or more).~~

~~Where roadside bodies of water (with seasonal water depth in excess of 3 feet for 24 hours or longer) lie within the roadside clear zone, they shall be shielded using guardrail or another longitudinal barrier.~~

~~For rural and urban flush shoulder highways, the distance from the outside edge of the through travel lane to the top of the canal side slope nearest the road will be no less than 60 ft. for highways with design speeds of 50 mph or greater. For highways with design speeds less than 50 mph this minimum distance shall not be less than 50 ft. for rural and urban flush shoulder highways or 40 ft. for urban curb or curb and gutter highways. When new canal or roadway alignment is required, distances greater than those above should be provided, if possible, to accommodate possible future improvements to the roadway (widening, etc.). If the minimum standards for canal hazards cannot be met, then shielding should be considered.~~

Suggested Wording:

Roadside canals and other bodies of water close to the roadway should be eliminated wherever feasible. Roadside water bodies that do not meet the definition of a canal hazard shall be located outside the clear zone shown in Table 4 – 1. For canal hazards on arterial or collector roadways, ^[KM10] additional lateral offset is required. A canal hazard is defined as an open ditch parallel to the roadway for a minimum distance of 1,000 feet and with a seasonal water depth in excess of 3 feet for extended periods of time (24 hours or ^[KM11] ^[KM12] ^[KM13] more).

Canal hazard lateral offset is the distance from the edge of travel lane, auxiliary lane or ramp to the top of the canal side slope nearest the road. Minimum required lateral offset distances are as follows (also see Figure 4 – 6 Minimum Offsets for Canal Hazards Rural and Urban Flush Shoulders and Figure 4 – 7 Minimum Offsets for Canal Hazards):

- Not less than 60 feet for flush shoulder and curbed roadways with design speeds of 50 mph or ^[KM14] greater.
- Not less than 50 feet for flush shoulder roadways with design speeds less than 50 mph.
- Not less than 40 feet for curb or curb and gutter roadways with design speeds 45 mph and less.

On new alignments and/or for new canals, greater distances should be provided to accommodate future widening of the roadway.

On fill sections, a flat berm (maximum 1:10 slope) no less than 20 feet in width between the toe of the roadway front slope and the top of the canal side slope nearest the roadway should be provided.

When the slope between the roadway and the "extended period of time" water surface is 1:6 or flatter, the minimum distance can be measured from the edge of the travel lane, auxiliary lane, or ramp to the "extended period of time" water surface and a berm is not required.

On sections with ditch cuts, a minimum of 20 feet between the toe of the front slope and the top of the canal side slope nearest the roadway should be provided.

When the required minimum lateral offset cannot be met, the canal hazard shall be shielded with a crashworthy roadside barrier. Barriers shall be located as far from the travel way as practical. When shielding canal hazards the barrier shall be located outside the clear zone where possible. Guardrail shall be located no closer than 6 feet from the canal front slope and high tension cable barrier shall be no closer than 15 feet from the canal front slope.

**Figure 4 – 6 Minimum Offsets for Canal Hazards
Rural and Urban Flush Shoulders**

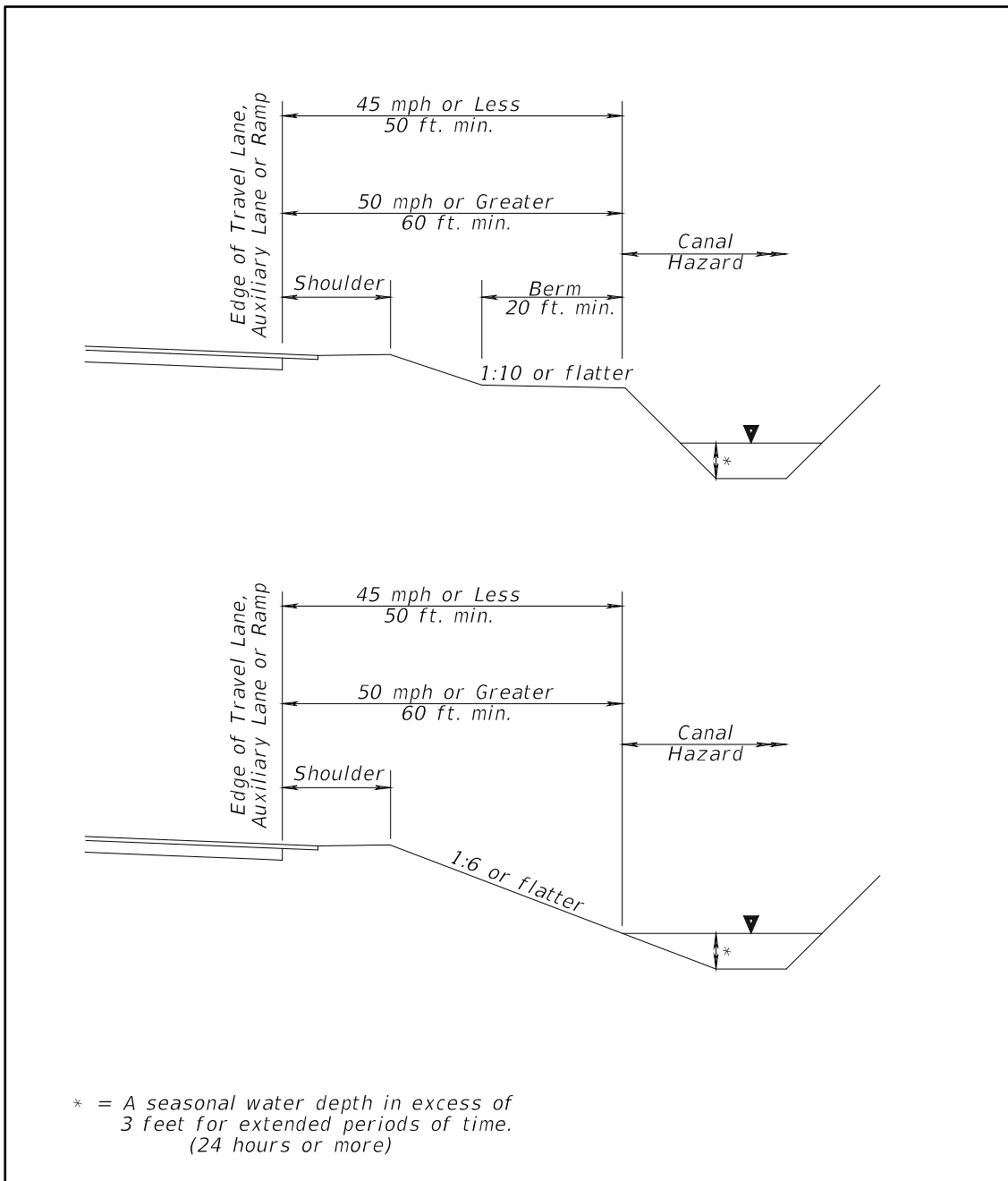
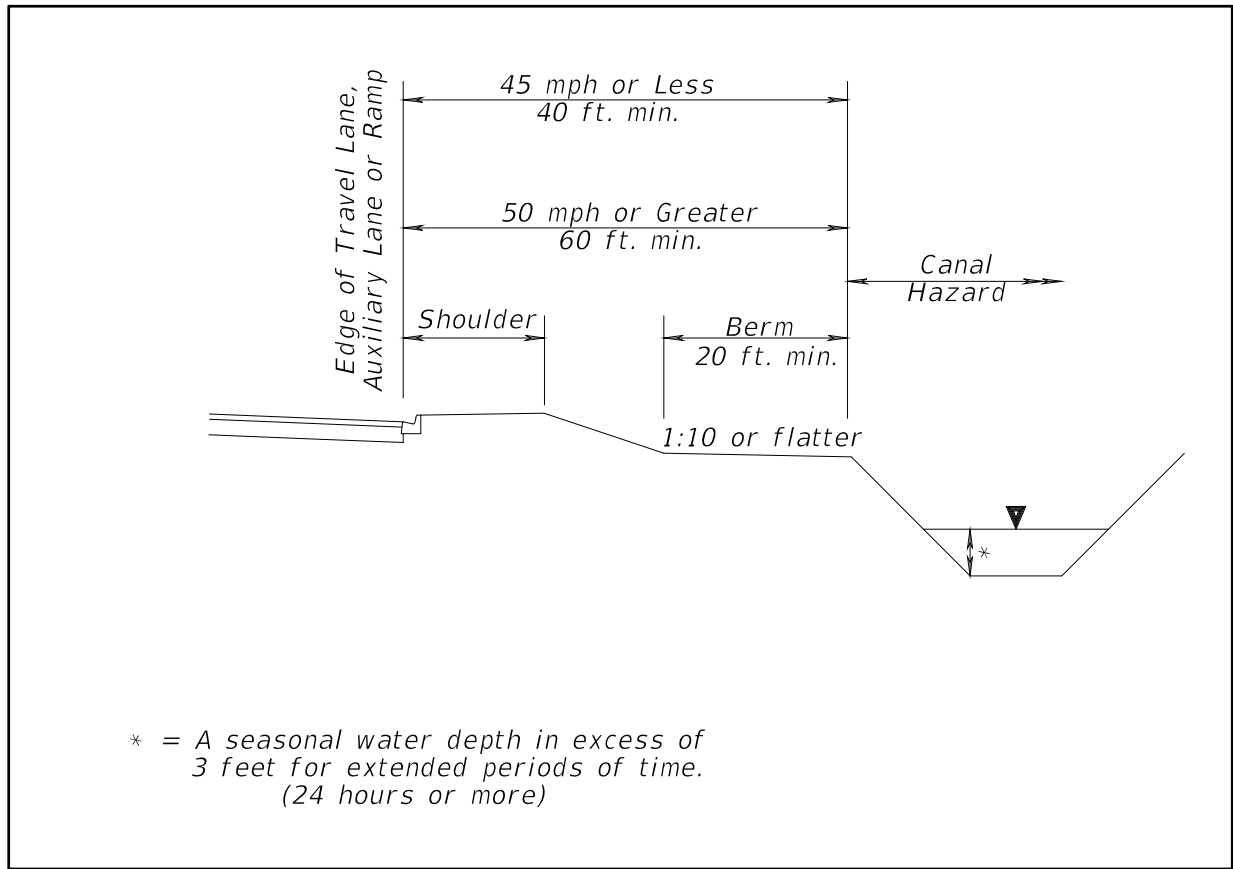

Figure 4 – 7 Minimum Offsets for Canal Hazards
Urban Curb or Curb and Gutter [KM15]



B.2.d Curb

Curbs with closed drainage systems are typically used in urban areas to minimize the amount of right of way needed. Curbs also provide a tangible definition of the roadway limits and delineation of access points. These functions are important in urban areas because of the following typical characteristics:

- Low design speed (Design Speed \leq 45 mph);
- Dense abutting development;
- Closely spaced intersections and accesses to property;

- Higher number of motorized vehicles, bicyclists and pedestrian volumes, and;
- Restricted right of way.

Chapter 3 – Geometric Design provides criteria on the use of curbs. It should be noted that curbs have no redirection capabilities except at very low speeds; less than the lowest design speeds typically used for urban streets. Therefore, curb should not be considered effective in shielding a hazard and is not to be used to reduce lateral offset requirements.

The Department's **Design Standards Index 300** provides standard details for curb shapes commonly used in Florida. Typical applications for urban roadways include Type E and Type F curbs. Both curb types have a sloped face; however, the Type E has a flatter face to allow vehicles to traverse it more easily. Shoulder gutter is also frequently used along roadway fill sections and bridge approaches to prevent excessive runoff down embankment slopes. The Department's **Drainage Manual** may be referenced for direction on the use of shoulder gutter.

Curbs types such as Type E (height 5" or less with a sloping face equal to or flatter than the Type E) may be used in the following cases on high speed roadways. The face of the curb shall be placed no closer to the edge of the traveled way than the required shoulder width.

- High speed multilane divided highways with design speeds 55 mph and less. For examples see the Department's **Plans Preparation Manual**.
- Directional Median Openings. For examples see the Department's **Design Standards Index 527**^[KM16].
- Transit Stops (harmonize with flush shoulder accessible transit stops).

C ROADSIDE SAFETY FEATURES AND CRASH TEST CRITERIA OBJECTIVES

While a traversable and unobstructed roadside is highly desirable from a safety standpoint, some appurtenances near the traveled way are necessary. Man-made fixed objects that frequently occupy road rights-of-way include traffic signs, traffic signals, roadway lighting, railroad warning devices, intelligent transportation systems (ITS), utility poles, mailboxes. Other features include safety hardware such as barriers, end treatments and crash cushions which are often necessary to shield errant motorists from a variety of roadside hazards.

These features are in addition to trees and other vegetation often present, either naturally occurring or as part of landscaping. Applicable criteria for each of these features is presented in the following sections. Certain features are required to meet specific crash test criteria involving full scale crash testing.

C.1 Crash Test Criteria

Crash test criteria for roadside safety features has been in existence since 1962, but has changed over time as the vehicle fleet changes, and crash characteristics and hardware performance becomes better understood. ***NCHRP Report 350, Recommended Procedures for the Safety Performance Evaluation of Highway Features***, published in 1993, has been the accepted criteria for safety hardware device testing for many years.

More recently, the ***AASHTO Manual for Assessing Safety Hardware (MASH)*** was published and has superseded ***NCHRP Report 350*** as the most current criteria. To allow adequate time for the testing and development of features under MASH criteria, safety hardware installed on new and reconstruction projects shall meet ***NCHRP Report 350*** crash test criteria as a minimum. For projects on the National Highway System, a schedule has been established for implementing requirements for devices meeting MASH criteria. For more information see FHWA's Web Site for ***Roadway Departure Safety***. New and reconstruction projects not on the National Highway System are not required to conform to this implementation schedule, but should comply to the extent practical.

The Department maintains standard details, specifications and approved products for all types of roadside devices commonly used in Florida that meet the required crash test criteria, and are acceptable for use on all public roadways. Non-

proprietary, standardized devices are detailed in the Departments **Design Standards**. Proprietary products are included on the Department's **Approved Product List (APL)**. These devices address the majority of roadside needs for all roads in Florida. The most current version of the **Design Standards** and **APL** should be used as the Department maintains and updates these publications as necessary to comply with required implementation dates for changes in crash test criteria.

For cases where a device may be needed that is not covered by the Department's standards and approved products, the Federal Highway Administration (FHWA) maintains lists of eligible crashworthy devices, which can found on their website for **Roadway Departure Safety**. In addition, the AASHTO-Associated General Contractors of America (AGC)-American Road and Transportation Builders Association (ARTBA) Joint Committee Task Force 13 report, *A Guide to Standardized Highway Barrier Hardware*, provides engineering drawings for a multitude of barrier components and systems.

The criteria for crash testing specified in **NCHRP Report 350** and **AASHTO MASH** provides six Test Levels (TL-1 thru TL-6) for the evaluation of roadside hardware suitability. A test level is defined by impact speed and angle of approach, and the type of test vehicle. Test vehicles range in size from a small car to a loaded tractor trailer truck. Each Test Level provides an increasing level of service in ascending numerical order.

Tables 4 – 3 Test Levels for Barriers, End Terminals, Crash Cushions and 4 – 4 Test Levels for Breakaway Devices, Work Zone Traffic Control Devices summarize the vehicle types, vehicle mass, test speeds and impact angles used in testing for each test level. Tables 4 – 3 and 4 – 4 also show the differences in vehicle mass between MASH and **NCHRP Report 350** criteria for the small car, pickup and single unit truck test vehicles.

In addition to differences in vehicle mass, MASH test criteria incorporated several other changes that differ from **NCHRP Report 350**. For additional information on crash test criteria, refer to the **AASHTO MASH**, **NCHRP Report 350**, the **AASHTO Roadside Design Guide**, and the FHWA web site for **Roadway Departure Safety**.

Table 4 – 3 Test Levels for Barriers, End Terminals, Crash Cushions

<u>Test Level</u>	<u>Test Vehicle Type</u>	<u>Vehicle Designation and Mass</u>		<u>Test Conditions MASH</u>	
		<u>NCHRP 350 (lbs.)</u>	<u>MASH (lbs.)</u>	<u>Impact Speed (mph)</u>	<u>Impact Angle (for Barriers) (degrees)</u>
<u>1</u>	<u>Passenger Car Pickup Truck</u>	<u>820C 1800 2000P 4400</u>	<u>1100C 2420 2270P 5000</u>	<u>31 31</u>	<u>25 25</u>
<u>2</u>	<u>Passenger Car Pickup Truck</u>	<u>820C 1800 2000P 4400</u>	<u>1100C 2420 2270P 5000</u>	<u>44 44</u>	<u>25 25</u>
<u>3</u>	<u>Passenger Car Pickup Truck</u>	<u>820C 1800 2000P 4400</u>	<u>1100C 2420 2270P 5000</u>	<u>62 62</u>	<u>25 25</u>
<u>4</u>	<u>Passenger Car Pickup Truck Single-Unit Truck</u>	<u>820C 1800 2000P 4400 8000S 17640</u>	<u>1100C 2420 2270P 5000 10000S 22000</u>	<u>62 62 56</u>	<u>25 25 15</u>
<u>5</u>	<u>Passenger Car Pickup Truck Tractor-Van Trailer</u>	<u>820C 1800 2000P 4400 36000V 79300</u>	<u>1100C 2420 2270P 5000 36000V 79300</u>	<u>62 62 50</u>	<u>25 25 15</u>
<u>6</u>	<u>Passenger Car Pickup Truck Tractor-Tank Trailer</u>	<u>820C 1800 2000P 4400 36000V 79300</u>	<u>1100C 2420 2270P 5000 36000V 79300</u>	<u>62 62 50</u>	<u>25 25 15</u>
<u>Note: Test Levels 1, 2 and 3 apply to end terminals and crash cushions, while all 6 Test Levels apply to barriers.</u>					

Table 4 – 4 Test Levels for Breakaway Devices, Work Zone Traffic Control Devices

<u>Test Level</u>	<u>Feature</u>	<u>Test Vehicle Type</u>	<u>Vehicle Designation and Mass</u>		<u>Impact Speeds</u>		<u>Impact Angle (degrees)</u>
			<u>NCHRP 350 (lbs.)</u>	<u>MASH (lbs.)</u>	<u>Low Speed (mph)</u>	<u>High Speed (mph)</u>	
2	<u>Support Structures and Work Zone Traffic Control Devices</u>	<u>Passenger Car Pickup Truck</u>	<u>820C 1800 Not Required</u>	<u>1100C 2420 2270P 5000</u>	<u>19</u> <u>19</u>	<u>44</u> <u>44</u>	<u>0 – 20</u> <u>0 – 20</u>
	<u>Breakaway Utility Poles</u>	<u>Passenger Car Pickup Truck</u>	<u>820C 1800 Not Required</u>	<u>1100C 2420 2270P 5000</u>	<u>31</u> <u>31</u>	<u>44</u> <u>44</u>	<u>0 – 20</u> <u>0 – 20</u>
3	<u>Support Structures and Work Zone Traffic Control Devices</u>	<u>Passenger Car Pickup Truck</u>	<u>820C 1800 Not Required</u>	<u>1100C 2420 2270P 5000</u>	<u>19</u> <u>19</u>	<u>62</u> <u>62</u>	<u>0 – 20</u> <u>0 – 20</u>
	<u>Breakaway Utility Poles</u>	<u>Passenger Car Pickup Truck</u>	<u>820C 1800 Not Required</u>	<u>1100C 2420 2270P 5000</u>	<u>31</u> <u>31</u>	<u>62</u> <u>62</u>	<u>0 – 20</u> <u>0 – 20</u>

Note: Criteria for Test Levels 2 and 3 are provided for support structures, work zone traffic control devices and breakaway utility poles. Test Level 3 is the basic test level used for most devices.

As noted in Tables 4 – 3 and 4 – 4, Test Levels 1 through 3 are limited to passenger vehicles while Test Levels 4 through 6 incorporate heavy trucks. The test speeds and impact angles used for testing represent approximately 92.5% of real word crashes. As implied by the information in Tables 4 – 3 and 4 – 4:

1. Test Level 1 devices should be used only on facilities with design speeds 30 mph and less.

2. Test Level 2 devices should be used only on facilities with design speeds 45 mph and less.
3. Test Level 3 through Test Level 6 devices are considered acceptable for all design speeds.
4. Test Level 3 devices are generally considered acceptable for facilities of all types and most roadside conditions.
5. Test Levels 4 through 6 should be considered on facilities with high volumes of heavy trucks and/or where penetration beyond the barrier would result in high risk to the public or surrounding facilities.

For additional information regarding appropriate application of Test Levels refer to the **AASHTO Roadside Design Guide**.

C.2 Safety Hardware Upgrades

On new construction and reconstruction projects existing obsolete safety hardware shall be upgraded or replaced with hardware meeting crash test criteria as described above.

For existing roadways, highway agencies should upgrade existing highway safety hardware to comply with current crash test criteria either when it becomes damaged beyond repair, or when an individual agency's maintenance policies require an upgrade to the safety hardware.

The Department's **Plans Preparation Manual** provides a list of considerations when investigating the need for upgrading barriers and other hardware. The Department's Design Standards provide standard details for transitioning new barriers to existing barriers. The **AASHTO Roadside Design Guide** also provides guidelines for upgrading hardware.

~~General objectives to be followed in roadside design are to provide an environment that will reduce the likelihood and/or consequences of crashes by vehicles that have left the traveled way. The achievement of this general objective will be aided by the following:~~

- ~~• Roadside areas adequate to allow reasonable space and time for a driver to regain or retain control of the vehicle and stop or return to the traveled way safely.~~
- ~~• Shoulders, medians, and roadsides that may be traversed safely without vehicle vaulting or overturning.~~

- ~~Location of roadside fixed objects and hazards as far from the travel lane as is economically feasible.~~
- ~~Roadsides that accommodate necessary maintenance vehicles, emergency maneuvers and emergency parking.~~
- ~~Protection of pedestrians, workers, or other persons subjected to the hazard of errant vehicles.~~
- ~~Adequate protective devices (where hazards are unavoidable) compatible with vehicle speeds and other design variables.~~

D **SIGNS, SIGNALS, LIGHTING SUPPORTS, UTILITY POLES, TREES AND SIMILAR ROADSIDE FEATURES** **ROADSIDE DESIGN**

D.1 General

This section provides criteria for traffic sign supports, signal supports, lighting supports, utility poles, trees and similar roadside features.

Generally, those roadside appurtenances and features that cannot be removed or located outside the clear zone must meet breakaway criteria to reduce impact severity. For those features located within the clear zone where it is not practical to meet breakaway criteria, shielding may be warranted and shall be considered.

D.2 Performance Requirements for Breakaway Devices

The term breakaway support refers to traffic sign, highway lighting, and other supports that are designed to yield, fracture, or separate when impacted by a vehicle. The release mechanism may be a slip plane, plastic hinge, fracture element, or combination thereof. Crash test criteria applicable to breakaway devices are presented in Section C. Additional requirements for breakaway supports are provided in the ***AASHTO Standard Specifications for Structural Supports for Highway Signs, Luminaries, and Traffic Signals***. For a more detailed discussion on breakaway supports, refer to the ***AASHTO Roadside Design Guide***.

See Section C for references that provide additional information and details on crash tested breakaway supports.

D.3 Sign Supports

Traffic signs and sign supports shall meet the requirements provided in the ***Manual on Uniform Traffic Control Devices (MUTCD)*** as stated in ***Chapter 18 – Signing and Marking***. The ***MUTCD*** requires all sign supports within the clear zone to be shielded or breakaway. See Section B for clear zone requirements. Only when the use of breakaway supports is not practicable should a traffic barrier or crash cushion be used exclusively to shield sign supports. In addition, sign supports should be located where they are least likely to be hit. Where possible, signs should be placed behind existing roadside barriers beyond the design deflection distance or on existing structures.

The Department's **Design Standards** Index 11000 Series provides details for breakaway supports for single and multi-post ground mounted signs that are acceptable for use within the clear zone. The most current version of these **Design Standard** details should be used as the Department maintains and updates these details as necessary to comply with required implementation dates for changes in crash test criteria.

Overhead signs and cantilever signs require relatively large size support systems. The potential safety consequences of these systems falling necessitate a fixed-base design that cannot be made breakaway. Overhead sign and cantilever sign supports therefore are required to be located outside the clear zone (Section B) or be shielded with a crashworthy barrier (Section E). Where possible, these supports should be located behind traffic barriers shielding nearby overpasses or other existing structures, or the signs should be mounted on the nearby structure. The Department's **Design Standards**^[KM18] **Indexes 11870** and **11871** provide details and instructions for the design of these systems.

D.4 Traffic Signal Supports

Traffic signal supports commonly used in Florida are fixed base and shall meet the required lateral offset and clear zone criteria provided in Section B. Traffic signal supports should not be located within medians. The Department's **Design Standards Indexes 17700 Series** provide details and instructions for the design of traffic signal supports.

D.5 Lighting Supports

Lateral offset criteria for lighting supports depend on whether the support is breakaway or fixed base as discussed below. See **Chapter 6 - Lighting** for additional design criteria for lighting.

D.5.a Conventional Lighting

Supports for conventional lighting (heights up to 60 feet) shall be breakaway which are typically frangible bases (cast aluminum transformer bases), slip bases, or frangible couplings (couplers). The Department's **Design Standards Indexes 17500** and **17515** provide further information for breakaway lighting supports which are acceptable for use. As a general rule, a breakaway lighting support will fall near the line of the path of an

impacting vehicle. The mast arm usually rotates and points away from the roadway when resting on the ground. For poles located on the outside of the roadway (not in medians), this action generally results in the pole not falling into other traffic lanes. However, the designer should remain aware that these falling poles may endanger other motorists or bystanders such as pedestrians and bicyclists. The **AASHTO Roadside Design Guide** may be referenced for additional discussion on breakaway lighting supports.

On curbed roadways with design speeds 45 mph or less, breakaway lighting supports shall be located to meet lateral offset requirements provided in Section B, Table 4 – 2.

On flush shoulder roadways, breakaway lighting supports shall be located a minimum of 20 feet from the nearest travel lane, 14 feet from the nearest auxiliary lane or outside the clear zone provided in Section B, Table 4 – 1, whichever is less. The foreslope shall be 6:1 ^[KM19] or flatter in cases where supports are located within the clear zone.

Lighting should not be located in medians, except in conjunction with barriers that are justified for other reasons.

D.5.b High Mast Lighting

High mast or high-level lighting supports are fixed-base support systems that do not yield or break away on impact. High mast lighting supports shall be located outside the clear zone provided in Section B, Table 4 – 1. High mast lighting shall not be located in medians except in conjunction with barriers that are justified for other reasons. **Design Standards Index 17502** provides additional information.

D.6 Utility Poles

Utility poles shall be located to meet lateral offset and clear zone requirements provided in Section B and be located as close as practical to the right of way line. They should be installed per the permitting agent's requirements. ~~For roads on the State Highway System, utility poles shall conform to the requirements of the Department's. For all other roadways, the UAM applies only when adopted by the local agency.~~ The **AASHTO Roadside Design Guide** provides additional discussion and guidance on utility poles.

D.7 Trees

Trees with a diameter greater than 4 inches measured 6 inches above grade shall be located to meet lateral offset and clear zone requirements in Section B, Tables 4 – 1 and 4 – 2. The *AASHTO Roadside Design Guide* provides additional discussion and guidance on trees.

D.8 Miscellaneous

D.8.a Fire Hydrants

Most fire hydrants are made of cast iron and are expected to fracture upon impact, however, crash testing meeting current criteria has not been done to verify that designs meet breakaway criteria. For this reason, fire hydrants should be located as far from the travel way as practical and preferably outside lateral offset/clear zone requirements in Section B, yet where they are still readily accessible to and usable by emergency personnel. Any portion of the hydrant not designed to break away should be within 4 inches of the ground.

D.8.b Railroad Crossing Warning Devices

See *Chapter 7 - Rail-Highway Crossings* for location requirements for railroad crossing warning devices.

D.8.c Mailbox Supports

Mailboxes and their location are subject to US Postal Service requirements. They are often located within the clear zone and pose a potential hazard. However, with proper design and placement, the severity of impacts with mailboxes can be reduced. To achieve consistency, it is recommended each highway agency adopt regulations for the design and placement of mail boxes within the right of way of public highways. The *AASHTO Roadside Design Guide* provides a model regulation that is compatible with US Postal Service requirements.

The following requirements apply to mailbox installations on public roadways:

No mailbox will be permitted where access is obtained from a freeway or where access is otherwise prohibited by law or regulation. Mailboxes shall be located as follows:

- On the right-hand side of the roadway in the carrier's direction of travel except on one-way streets, where they may be placed on the left-hand side.
- Where a mailbox is located at a driveway entrance, it shall be placed on the far side of the driveway in the carrier's direction of travel.
- Where a mailbox is located at an intersecting road, it shall be located a minimum of 200 feet beyond the center of the intersecting road in the carrier's direction of travel. This distance may be decreased to 100 feet on very low volume roads.
- When a mailbox is installed in the vicinity of an existing guardrail, it should, when practical, be placed behind the guardrail.

The bottom of the box shall be set at a height established by the U. S. Postal Service, usually from 41 to 45 inches above the roadway surface [KM20].

On flush shoulder roadways, the roadside face of the box shall be offset from the edge of the traveled way a distance no less than the greater of the following:

- 8 feet (where no paved shoulder exists and shoulder cross slope is 10 percent or flatter), or
- width of the shoulder present plus 6 to 8 inches, or
- width of a turnout specified by the jurisdiction plus 6 to 8 inches [KM21].

On very low volume flush shoulder roads with low operating speeds the offset may be reduced to 6 feet from the traveled way. On very low volume roads with low operating speeds the offset may be reduced to as low as 32 inches when approved by the maintaining agency.

On curbed streets, the roadside face of the mailbox shall be set back from the face of the curb at a distance of between 6 and 8 inches. On residential streets without curbs or all-weather shoulders that carry low traffic volumes operating at low speeds, the roadside face of the mailbox shall be offset between 8 inches and 12 inches behind the edge of the pavement.

Design criteria for the mailbox support structure when located within the clear zone should consist of the following:

- Mailboxes shall be of light sheet metal or plastic construction conforming to the requirements of the U. S. Postal Service. Newspaper delivery boxes shall be of light metal or plastic construction of minimum dimensions suitable for holding a newspaper.
- No more than two mailboxes may be mounted on a support structure unless crash tests have shown the support structure and mailbox arrangement to be safe. However, light-weight newspaper boxes may be mounted below the mailbox on the side of the mailbox support.
- Mailbox supports shall not be set in concrete unless crash tests have shown the support design to be safe.
- A single 4 inch by 4 inch square or 4 inch diameter wooden post; or metal post, Schedule 40, 2 inch (normal size IPS (external diameter 2-3/8 inch) (wall thickness 0.154 inches) or smaller), embedded no more than 24 inches into the ground, shall be acceptable as a mailbox support. A metal post shall not be fitted with an anchor plate, but it may have an anti-twist device that extends no more than 10 inches below the ground surface.
- Unyielding supports such as heavy metal pipes, concrete posts, brick, stone or other rigid foundation structure or encasement should be avoided.
- The post-to-box attachment details should be of sufficient strength to prevent the box from separating from the post top if the installation is struck by a vehicle. The exact support hardware dimension and design may vary, such as having a two-piece platform bracket or alternative slot-and-hole locations. The product must result in a satisfactory attachment of the mailbox to the post, and all components must fit together properly.
- The minimum spacing between the centers of support posts shall be the height of the posts above the ground line. Mailbox support designs not described in this regulation are acceptable if approved by the jurisdiction.

The FDOT Design Standards and the AASHTO Roadside Design Guide provides details on hardware, supports and attachment details acceptable for mailboxes located within the clear zone which conform to

the above requirements.

D.8.d Bus Benches and Shelters

See **Chapter 3 - Geometric Design** for location criteria for bus benches and shelters. Additional criteria is provided in **Chapter 13 - Public Transit**.

~~The basic requirements and standards for the design of shoulders, medians, and roadsides are given in **Chapter 3 - Geometric Design**. This includes specific requirements regarding widths, slopes, and changes in grade. General requirements for drainage facilities, utilities, transit, and pedestrian facilities are also included.~~

~~This chapter contains general guidelines for particular situations encountered in roadside design due to the variety and complexity of possible situations encountered. The designer should utilize the following as basic guidelines to develop a safe roadside design.~~

~~Prior to any other consideration, the designer should attempt to:~~

- ~~1. Eliminate the hazard;
 - ~~a. Remove the hazard;~~
 - ~~b. Relocate the hazard outside of the clear zone;~~
 - ~~c. Make the hazard traversable or crashworthy.~~~~
- ~~2. Shield the hazard with a longitudinal barrier or crash cushion.~~
- ~~3. Leave the hazard unshielded. This treatment is taken only when the barrier or crash cushion is more hazardous than the hazard.~~

~~The AASHTO Roadside Safety Analysis Program (RSAP) is the recommended tool for evaluating the cost effectiveness of shielding roadside hazards.~~

D.1 Geometric Changes

D.1.a Horizontal Curves

~~On horizontal curves, consideration should be given to increasing the clear zone above the minimum requirements due to the increased likelihood of vehicles leaving the traveled way. Increasing clear zone widths and~~

~~decreasing roadside slopes on curves is also important since a vehicle will probably leave the traveled way at a steeper exit angle. Increasing clear zone widths on curves is also beneficial in improving the available sight distance. Proper signage should be part of every roadside design. For proper signage to inform drivers of approaching curves, refer to the MUTCD~~

D.1.b — Vertical Curves

~~As a vehicle comes over the crest of a vertical curve, the driver may suddenly be presented with a situation requiring an emergency maneuver. The provision of adequate clear zones is particularly important where available stopping sight distance may not be adequate or where driver expectancy may be violated. High traffic volumes (i.e., urban areas) may result in rapidly forming traffic queues, thus tending to cause rear end collisions. Vertical curves with inadequate stopping sight distance may be mitigated with appropriate advanced signage and other warning devices, or can be reconstructed.~~

D.1.c — Changes in Cross Section

~~The provision of adequate clear zone is very important at exits, entrances, lane drops, or other changes in the roadway cross section. The exterior boundaries of the clear zone should extend well beyond any reductions in roadway width and then gradually reduce to provide design width for the new roadway cross section.~~

D.1.d — Decision or Conflict Points

~~Adequate clear zones should be provided at any point of traffic merging or conflicts, and at locations where the driver is confronted with making a decision regarding vehicle maneuvers.~~

D.2 — Fills

~~Many roadways, for drainage purposes, are elevated somewhat above the surrounding terrain. Where feasible, the side slopes should not exceed a ratio of 1:4. On flatter slopes (1:6 or greater), care should be exercised to eliminate sharp changes in grade or other discontinuities.~~

If the side slope is steeper than 1:3, longitudinal barriers should be considered.

D.3—Cuts

A primary objective of roadside design in cut sections is to prevent conditions tending to cause rollovers or serious collisions with the cut slopes. When the material (soils) in the cut is smooth and stable, the use of an increasing backslope is a reasonable solution. The technique is also acceptable in stable rock cuts, provided that smooth fill material is utilized to affect the backslope.

The use of a rigid barrier incorporated into the cut slope is also satisfactory for rock slopes. Where the material in the cut is irregular or unstable, a longitudinal barrier offset from the cut face should be utilized.

D.4—Roadside Canals

Roadside canals or other bodies of water close to the roadway should be eliminated wherever feasible. A canal is defined as an open ditch parallel to the roadway for a minimum distance of 1000 ft. and with a seasonal water depth in excess of 3 ft. for extended periods of time (24 hours or more).

Where roadside bodies of water (with seasonal water depth in excess of 3 feet for 24 hours or longer) lie within the roadside clear zone, they shall be shielded using guardrail or another longitudinal barrier.

For rural and urban flush shoulder highways, the distance from the outside edge of the through travel lane to the top of the canal side slope nearest the road will be no less than 60 ft. for highways with design speeds of 50 mph or greater. For highways with design speeds less than 50 mph this minimum distance shall not be less than 50 ft. for rural and urban flush shoulder highways or 40 ft. for urban curb or curb and gutter highways. When new canal or roadway alignment is required, distances greater than those above should be provided, if possible, to accommodate possible future improvements to the roadway (widening, etc.). If the minimum standards for canal hazards cannot be met, then shielding should be considered.

The RSAP is the recommended tool for evaluating the cost effectiveness of shielding roadside hazards.

D.5—Vegetation

~~The proper use of natural vegetation can provide valuable and economical assistance in developing aesthetic and traversable roadsides.~~

D.5.a—Stability

~~The use of grass or other easily maintained, low-growing vegetation may be used on medians and roadsides. This vegetation should be carefully maintained so vehicles can safely traverse those areas.~~

D.5.b—Drainage

~~Drainage swales may be protected from hazardous scouring (alteration of safe ditch contour) by the appropriate vegetation. Grass, vines, or other plants can be beneficial in stabilizing embankments to prevent erosion of material onto adjacent roadways. The appropriate use of grass or shrubbery can also aid in retarding runoff in the vicinity of the roadway, thus benefiting the overall drainage pattern.~~

D.5.c—Environmental and Aesthetic Considerations

~~The use of natural grass and shrubbery for borders along roadways provides an important environmental asset. This border serves as a preserved green belt that minimizes the adverse impact (dirt, noise, etc.) of a street or highway. The use of a wide, gently flowing grassed roadside of varying width is generally an aesthetically pleasing design.~~

D.5.d—Landscaping—Design Considerations

~~The Department's *Design Standards (Index Numbers 544 – Landscape Installations, and 546 – Sight Distance at Intersections)*, contain information on landscaping that may be considered. *Index 544* provides landscape installation details. The Department also produces the "Florida Highway Landscaping Guide" which is an excellent landscaping information source.~~

~~*Standard Index 546* provides information on landscaping in vicinities of~~

~~conventional intersections. For roundabout landscape guidelines and related sight line requirements, refer to [NCHRP 672 "Roundabouts: An Informational Guide."](#)~~

D.6—Drainage

~~Proper drainage of the pavement, shoulders, median, and roadsides is important for maintaining a safe street or highway. Techniques utilized for providing drainage should result in safe vehicle operation on or off the roadway.~~

D.6.a—Inlets

~~Drainage inlets should not be placed in a bus bay, travel, or bike lane and should not be placed in a shoulder, except at the exterior edge, when drainage restrictions are severe. Drainage inlets within the median or roadside(s) shall be traversable. A small area around the inlet should be paved to improve drainage and to prevent localized erosion. Corner radii inlets should be avoided as they hinder pedestrians, create ponding, create maintenance problems, and complicate intersection design.~~

D.6.b—Ditches

~~Drainage ditches perpendicular to the roadway should not be used within the median or roadsides. All drainage ditches within the median or roadsides shall meet the requirements for slopes and changes in grade given in [Chapter 3 – Geometric Design](#).~~

D.6.c—Culverts

~~Where culverts are unavoidable at intersections, the entrance and exit should be flush with the adjacent ground or located beyond the clear zone. The slope and changes in grade at the structure should conform to minimum requirements for roadsides. Culvert terminations at median crossovers should be constructed in a similar fashion.~~

~~Where culverts are required perpendicular to the roadway, they should be extended to the roadsides as a minimum. Headwalls at the culvert terminations (within the clear zone) should not protrude above the ground surface in excess of 4 inches. Sloping entrances and exits generally flush~~

~~with side slopes should be used wherever possible (even outside the clear zone). Proper ground contouring of the roadside approach can provide a relatively smooth surface that can be traversed with reasonable safety by an errant vehicle.~~

~~Cross drains and side drains within the clear zone should be equipped with mitered end sections. *FDOT Standard Index Series 200* provides requirements for the proper use of flared and mitered end sections.~~

D.7—Curbs

~~The basic criteria for prohibiting or permitting the use of curbs are given in Chapter 3—Geometric Design. Curbs serve any or all of the following purposes: drainage control, roadway edge delineation, right of way reduction, aesthetics, delineation of pedestrian walkways, reduction of maintenance operations, and assistance in orderly roadside development.~~

~~Curbs should not be used along freeways or other high-speed arterials, but if a curb is needed, it should not be located closer to the traveled way than the outer edge of the shoulder. In addition, sloping end treatments should be provided.~~

D.8—Poles and Support Structures

~~The location and design of poles or support structures for signs, signals, lighting, or other purposes is an important aspect of safe roadside design. All poles and support structures should be located outside the required clear zone when practical unless their supports are of the frangible or breakaway type. Non-breakaway poles and sign support structures may be located behind a barrier that is present for another reason. For proper offset from rigid obstacles to barriers, see section "E" of this chapter.~~

~~The function of a breakaway support is to minimize the vehicle deceleration and the probability of injury to vehicle occupants. The design of the support should also be adequate to prevent portions of the structure from penetrating the vehicle interior.~~

~~Small signs should be designed to bend over flush with the ground upon impact. Larger signs should be designed with multiple posts with slip joints at the base and a weakened section and fuse plate intended to act as a hinge at the bottom of the~~

sign.

~~Utility poles and structures not related to highway operations, should be located outside the clear zone and as close as practical to the edge of right of way, without aerial encroachment, and without violating National Electric Safety Code (NESC) clearances. New utility poles not placed at the edge of the right of way, and falling within the limits of the clear zone dimensions defined in Table 3-12 should be approved through the exception process prescribed in **Chapter 14 - Design Exceptions**. Placement within sidewalk shall be such that a minimum unobstructed sidewalk width of 32" is provided.~~

~~In accordance with **Section 337.403, Florida Statutes**, existing utility poles must be relocated when **unreasonably** interfering with the "convenient, safe, or continuous use, or the maintenance, improvement, extension, or expansion" of public roads. Utility poles adjacent to road improvement projects, but not directly interfering with construction, should be considered for relocation, to the extent they can be relocated, to achieve the clear zone requirements of Table 3-12. Utility poles that cannot be relocated and will remain within the clear zone, should be approved through the exception process prescribed in **Chapter 14 - Design Exceptions**.~~

D.9 Intersections

~~All poles or other structures not absolutely essential should not be located in the vicinity of the intersection. When joint use agreements can be arranged, the various governmental agencies, transit authorities, and utilities should consider the use of joint purpose single poles as a replacement for all poles or structures serving a single purpose. Light poles, traffic signal supports and boxes, transit stop signs, and all other street furniture should be moved back as far as is practical from the boundary of the roadsides.~~

~~Energy absorbing devices should be considered for protection of lighting and traffic signal supports located within the roadsides.~~

D.10 Underpasses

~~The full median and roadside should be carried through underpasses without interruption. Where it is not feasible to eliminate the supports, guardrail or another longitudinal barrier should be used. The barrier may be a rigid barrier incorporated~~

~~into the support columns or a guardrail set out from the supports. The barrier should be extended well beyond the supports.~~

~~D.11 Bridges and Overpasses~~

~~The required lateral offset (*Chapter 3 – Geometric Design*) should be maintained on all bridges, overpasses, or other elevated roadways. The full roadway cross section, including shoulders, should be carried across without interruption. Bridge railings should be designed and constructed in compliance with the requirements for redirection barriers. Particular emphasis should be placed on the prevention of structural failure and vaulting of the railing by errant vehicles.~~

~~On all high-speed roadways (design speed 50 mph or greater), the bridge railing or other barriers should be extended sufficiently (and properly terminated) to prevent vehicles from passing behind the barrier and entering the hazardous location. The transition between the bridge railing and the approach barrier should be smooth and continuous. Barrier curbs should not be placed in front of bridge railings or other barriers. Pedestrian facilities should be placed outside of the bridge railing or longitudinal barrier on all high-speed roadways.~~

~~It is desirable that twin bridges for nominal-width median divided highways be filled in the dividing area, carrying the median across the bridge without interruption. The gore area between diverging elevated roadways should be bridged over for a sufficient distance to allow for the placement of any energy absorbing devices. If twin bridges are used, the median layout should conform to *Chapter 3 – Geometric Design*.~~

~~See *Chapter 17 – Bridges and Other Structures* for additional requirements for bridges and bridge railings.~~

~~D.12 Mailboxes~~

~~Guidelines for the location of mailboxes, type of support and turnout construction, given in the Department's *Design Standards, Index 532 – Mailboxes* or *AASHTO – "A Guide for Erecting Mailboxes on Highways"*, should be considered.~~

~~D.13 Bus Shelters~~

~~Bus shelters should be moved back as far as practical from the roadside with pedestrian access to the bus stop boarding and alighting area at the roadside.~~

E BARRIERS, END TREATMENTS AND CRASH CUSHIONS PROTECTIVE DEVICES

~~Protective devices for roadside design may be considered as highway safety features intended to reduce the severity of run-off the road crashes. In those situations where the minimum safety standards for median and roadside are not feasible, protective devices should be considered. Longitudinal barriers should not be used indiscriminately, for at least two reasons: they are expensive to install and maintain, and they are closer to the road than the obstacles they are shielding. They should be used when they are warranted by the reduction in crash severity.~~

~~Refer to the *Florida DOT Plans Preparation Manual, Chapter 4 Roadside Safety* for additional information on roadside and median barriers and crash cushions.~~

E.1 Roadside Barriers Redirection Devices

Roadside barriers are used to shield motorists from roadside hazards and in some cases are used to protect bystanders, pedestrians, cyclists and/or workers from vehicular traffic. In still other cases, roadside barriers are used to protect bridge piers from vehicle impacts. Median barriers are similar to roadside barriers but are designed for vehicles striking either side and are primarily used to separate opposing traffic on a divided highway. Median barriers also may be used on heavily traveled roadways to separate through traffic from local traffic or to separate high occupancy vehicle (HOV) and managed lanes from general-purpose lanes. Barriers are further classified as rigid, semi-rigid and flexible which are discussed in more detail below.

Barrier transition sections are used between adjoining barriers that have significantly different deflection characteristics. For example, a transition section is needed where a semi-rigid guardrail attaches to the approach end of a rigid concrete bridge rail, or when a barrier must be stiffened to shield fixed objects.

Requirements for bridge railings are provided in **Chapter 17 - Bridges and Other Structures.**

~~Redirection devices are longitudinal barriers, such as guardrails, median barriers, and bridge railings placed parallel to the roadway to contain and redirect errant vehicles.~~

E.1.a — Function

~~The primary function of a longitudinal barrier is to redirect an errant vehicle away from hazardous roadside obstacles. The barrier should be designed to produce a minimum of adverse impacts (lateral and longitudinal) to a vehicle.~~

E.1.b — Warranting Conditions

~~Warranting conditions for the use of longitudinal barriers are essentially those conditions in which the overall probability of injuries and fatalities would be reduced by the use of these redirection devices. AASHTO's Roadside Design Guide contains warrants related to roadside barrier selection and placement.~~

E.1.c — Location

~~Ideally, the barrier should be located to minimize the likelihood of being struck by an errant vehicle. The barrier should be located outside the normal shoulder width. The location and orientation of the barrier should also be selected to minimize the angle of impact and the resulting vehicle deceleration.~~

~~Barriers shall be offset from obstacles or other hazards a sufficient distance so the barrier may deflect without interference. The location of the barrier should be selected in close coordination with the design of its deflection characteristics.~~

E.1.d — Length

~~The length of a longitudinal barrier should be sufficient to prevent a~~

~~vehicle, traveling in either direction, from passing behind the barrier and striking the hazard being shielded.~~

~~E.1.e — Vehicle Containment~~

~~Longitudinal barriers should have sufficient strength to prevent a vehicle from penetrating the barrier. Structural continuity and smoothness is also required to prevent rapid deceleration or penetration of the vehicle by any of the barrier components. The shape and height of the barrier should be adequate to deter overturning or vaulting of the vehicle. The surface in front of the barrier should be approximately perpendicular to the barrier and should be free from barrier curbs or other discontinuities.~~

~~E.1.f — Barrier Types~~

~~Longitudinal barriers may be generally classified as rigid or flexible. The recommended barriers in the following sections are intended as general guidelines only. As new types of barriers are developed and tested successfully, they may be incorporated into roadside design. They should, however, conform with the requirements previously established.~~

- ~~• — Rigid Barrier – Rigid barriers are generally less effective in controlling lateral vehicle deceleration at locations subject to high-angle impacts. The use of this barrier is recommended for bridge railings and for use at retaining walls, rock cuts, or other rigid hazards where space limitations are constrained.~~

- ~~• — Flexible Barrier – Barriers which yield somewhat on impact are often more useful in limiting the rate of vehicle deceleration. Special care should be exercised to ensure they are structurally adequate and they maintain a smooth continuous surface.~~

~~This type of barrier can be expected to deflect 2 to 5 feet under impact. The post spacing may be increased when a stiffer rail is utilized. The weak post barrier and the cable barrier can be expected to deflect 8 to 12 feet or more and should be limited to locations with adequate clear~~

~~space.~~

~~E.1.g~~ — Transitions

~~Changes in barrier types should be kept to a minimum. Transitions between two types of barriers should be smooth and continuous with no protruding components that could snag or penetrate a vehicle striking the barrier from either direction of travel. The transition from a flexible to a rigid barrier should be stiffened gradually to prevent "pocketing" of an errant vehicle.~~

~~E.1.h~~ — Terminations

~~Barrier terminations or interruptions should be kept to a minimum. The barrier termination should be designed to allow for a reasonably safe traversal by a vehicle traveling in either direction.~~

~~Roadside guardrails should be flared away from the roadway. The use of energy absorbing devices as the termination of the longitudinal barrier is an effective and acceptable procedure for both roadsides and medians.~~

E.2 End Treatments ~~Energy Absorbing Devices~~

End treatments include end anchorages, end terminals, and crash cushions. End anchorages are used to anchor a flexible or semi-rigid barrier to the ground to develop its tensile strength during an impact. End anchorages are not designed to be crashworthy for end on impacts. They are typically used on the trailing end of a roadside barrier on one-way roadways, or on the approach or trailing end of a flexible or semi-rigid barrier that is located outside the clear zone or that is shielded by another barrier system. End anchorages are discussed in more detail below.

End terminals are basically crashworthy anchorages. End terminals are used to anchor a flexible or semi-rigid barrier to the ground at the end of a barrier exposed to approaching traffic. Most end terminals are designed for vehicular impacts from only one side of the barrier, however some are designed for median applications where there is potential for impact from either side. End terminals are discussed in more detail below.

E.2.a — Function

~~The primary function of an energy absorbing device or crash cushion is to reduce the severity of impacts with fixed objects. These are utilized at locations where impact with the roadside obstacle would produce a greater deceleration rate. The deceleration rate is controlled by providing a cushion which deforms and absorbs energy while bringing the vehicle gradually to a stop.~~

E.2.b — Warranting Conditions

~~Crash cushions are used for the protection of occupants of an errant vehicle which might strike obstacles within the median or roadside that would produce excessive vehicle deceleration.~~

~~Other locations or situations that should be considered for crash cushions include:~~

- ~~• — Gore areas on elevated roadways~~
- ~~• — Intersections~~
- ~~• — Barrier terminations~~
- ~~• — Bridge abutments and supports~~
- ~~• — Retaining walls~~
- ~~• — Any other roadside object subject to impact by an errant vehicle~~

E.2.c — Design Criteria

~~The primary design criteria are the limitation of vehicle deceleration which is a function of the vehicle speed and the total crash cushion deformation.~~

~~The crash cushion should be located as far from the roadway as is practicable to reduce the likelihood of impact. Special care should be exercised in the design to reduce the probability of a vehicle overturning or vaulting the crash cushion.~~

E.2.d — Design Details

~~The development and testing of crash cushions are both recent and rapid. The rapidly expanding technology in this field requires the most recent research and experience be utilized in selecting a particular type of crash cushion. AASHTO's Roadside Design Guide provides guidance for the selection of sacrificial, re-useable and low maintenance crash cushion types.~~

E.3 Crash Cushions

Crash cushions, sometimes referred to as impact attenuators, are crashworthy end treatments typically attached at the approach end of median barriers, roadside barriers, bridge railings or other rigid fixed objects, such as bridge piers. Crash cushions may be used in a median, a ramp terminal gore, or other roadside application. Crash cushions are discussed in more detail below.

E.4 Performance Requirements

Roadside barriers, transitions, end terminals, and crash cushions must be crashworthy as determined by full scale crash testing in accordance with specific crash test criteria discussed in Section C. Descriptions of commonly used devices in Florida are described below. Section C also provides references where more information can be found on crashworthy devices.

E.5 Warrants

The determination as to when shielding is warranted for given hazardous roadside feature must be made on a case-by-case basis, and generally requires engineering judgment. It should be noted that the installation of roadside barriers presents a hazard in and of itself, and as such, the designer must analyze whether or not the installation of a barrier presents a greater risk than the feature it is intended to shield. The analysis should be completed using the ***Roadside Safety Analysis Program (RSAP)*** or in accordance with the ***AASHTO Highway Safety Manual (HSM)***.

Please see Section A for the considerations to be included when determining when to shield a roadside hazard.

The following hazards located within the clear zone are normally considered more hazardous than a roadside barrier:

E.5.a Above Ground Hazards

Above ground hazards are defined in Section B, Table 4-2 Lateral Offset. They include but are not limited to:

1. Bridge piers, abutments and railing ends
2. Parallel retaining walls with protrusions or other potential snagging features
3. Non breakaway sign and lighting supports
4. Utility Poles
5. Trees greater than 4" in diameter measured 6" above ground.

E.5.b Drop-Off Hazards

Drop-off hazards are defined in Section B, Table 4-2 Lateral Offset.

E.5.c Canals and Water Bodies

Criteria for addressing canal and water body hazards is provided in Section B.2.c.

E.5.d Medians

See **Chapter 3 - Geometric Design** for criteria for median barriers. The **AASHTO Roadside Design Guide** provides additional information and guidelines on the use of median barriers.

E.5.e Work Zones^[KM22]

Clear zone widths for work zones, as a minimum, shall be the lessor of clear zone requirements provided in Table 4 – 1, Table 4 – 5, or existing clear zone width. Clear zone widths in work zones are measured from the edge of Traveled Way defined by the Temporary Traffic Control (TTC) Plan.

Table 4 – 5 Clear Zone Width Requirements for Work Zones

<u>WORK ZONE POSTED SPEED</u> (mph)	<u>TRAVEL LANES & MULTILANE RAMPS</u> (feet)	<u>AUXILIARY LANES & SINGLE LANE RAMPS</u> (feet)
<u>All Speeds w/Curb & Gutter</u>	<u>4' Behind Face of Curb</u>	<u>4' Behind Face of Curb</u>
<u>Flush Shoulder</u>		
<u>30 – 40^{[KM23][KM24]}</u>	<u>14</u>	<u>10</u>
<u>45 – 50</u>	<u>18</u>	<u>10</u>
<u>55</u>	<u>24</u>	<u>14</u>
<u>60 – 70</u>	<u>30</u>	<u>18</u>

When clear zone widths cannot be met, the use of temporary barriers shall be considered. Temporary barriers in work zones can serve several functions:

- Shield edge drop-offs, excavation, roadside structures, falsework for bridges, material storage sites and/or other exposed objects
- Provide protection for workers.
- Separate two-way traffic.
- Separate pedestrians from vehicular traffic

The decision to use temporary barriers in a work zone should be based on engineering judgement and analysis. There are a number of factors, including traffic volume, traffic operating speed, offset, and duration, that affect barrier needs within work zones. The Department's **Design Standards, MUTCD** and the **AASHTO Roadside Design Guide** provides additional information and guidance on the use of temporary barriers in work zones.

E.6 Barrier Types

Roadside barriers are classified as flexible, semi-rigid and rigid depending on their deflection characteristics when impacted. Flexible systems have the greatest deflection characteristics. Given much of the impact energy is dissipated by the deflection of the barrier and lower impact forces are imposed on the vehicle, flexible systems are generally more forgiving than rigid and semi-rigid systems. Rigid barriers, on the other hand, are assumed to exhibit no deflection under impact conditions so crash severity will likely be the highest of the three classifications.

In the following sections are a basic descriptions of the barrier types commonly used in Florida for each these classifications. These commonly used barriers are those that are addressed in the FDOT Design Standards and FDOT Plans Preparation Manual. Those documents should be referenced for additional details and discussion on the proper use of these systems.

The basis for the Department's systems and devices, as well as many other generic and proprietary guardrail systems meeting **NCHRP Report 350** and/or MASH criteria, can be found in the following documents:

- **AASHTO Roadside Design Guide**
- Federal Highway Administration (FHWA) web site listing of eligible devices http://safety.fhwa.dot.gov/roadway_dept/policy_guide/road_hardware
- AASHTO-Associated General Contractors of America (AGC)-American Road and Transportation Builders Association (ARTBA) Joint Committee Task Force 13 report, A Guide to Standardized Highway Barrier Hardware available at <http://www.aashtotf13.org>

E.6.a Guardrail

The most commonly used barrier on new construction projects in Florida is the w-beam guardrail system detailed in the Department's **Design Standards Index 400** referenced as "General TL-3 Guardrail". This w-beam guardrail system, sometimes referred to as a strong post guardrail system, is a semi-rigid system, uses posts at 6'-3" spacing, 8" offset blocks, and mid-span splices with a rail height of 2'-1" to center of the panel. This system was developed based on the 31" Midwest Guardrail System (MGS) and meets MASH Test Level 3 criteria. Compatible proprietary components

may be referenced by the 31" height. This system can be used as a roadside barrier or in a double face configuration as a median barrier. Deflection space requirements for this system are provided in the Department's **Plans Preparation Manual**.

The current 31" height system replaces the 27" height system (1'-9" to center of panel) that had been used for many years and still present on roadways throughout Florida. Section C.3 addresses requirements for upgrading existing 27" height systems.

The Department's Design Standards also provides details for a similar w-beam guardrail system referenced as "Low Speed, TL-2 Guardrail", with posts at 12'-6" spacing which meets MASH Test Level 2 criteria. While this TL 2 system may be used on low speed roadways 45 mph or less, it preferably should be used only on roadways with design speeds 35 mph and less to account for the potential for changes in posted speed limits and/or vehicles exceeding the design speed.

To achieve a minimum level of crash performance, guardrail installations shall have a minimum length of 75 feet with design speeds greater than 45 mph.

E.6.b Concrete Barrier

The most commonly used concrete barriers in Florida are detailed in the Department's **Design Standards Index 410**. Details are provided for median application, shoulder application and pier protection. Additional information on these barriers is provided in the Department's **Plans Preparation Manual**.

The Department's 32" height F-Shape concrete barrier wall system that has been in use for many years meets NCHRP Report 350 Test Level 4 criteria and MASH Test Level 3 criteria. The Department is replacing this 32" F-Shape system with a 38" height single slope concrete barrier system which meets MASH Test Level 4 criteria. In addition to improved crash test performance, the single slope face provides for simpler construction.

While shielding bridge piers to protect motorists from a hazard within the clear zone is often necessary, some bridge piers may need shielding for

protection from damage due to design limitations (i.e. piers not designed for vehicular collision forces). Coordination with the Structural Engineer of Record is required to determine if pier protection is warranted. The Department's *Design Standards Index 411* provides details for crashworthy Pier Protection barriers and the *Plans Preparation Manual* provides a process for determining the appropriate level of pier protection. As with median and shoulder concrete barrier walls, the Department is replacing the F-Shape pier protection barriers that have been in use for several years with single slope face systems.

E.6.c High Tension Cable Barrier

There are a variety of crash tested flexible barrier systems using w-beam and cable, but they historically have not been in common use in Florida. In recent years several proprietary high-tension cable barrier (HTCB) systems have been developed that meet NCHRP Report 350 and MASH criteria. These systems are installed with a significantly greater tension in the cables than the generic low-tension systems that have been used in some states for many years. High tension cable barrier systems may be used for both median and roadside application. Deflection space requirements are dependent on the system, system^[KM25] length and post spacing, and are significantly greater than semi-rigid systems.

High tension cable barrier has shown to have several advantages over other types of flexible barrier systems. One advantage is they tend to result in less damage when impacted. Another is that certain systems have been tested for use on slopes as steep as 1:4. Still another advantage is that in many cases, the cables remain at the proper height after an impact that damages several posts. While no manufacturer claims their barrier remains functional in this condition, there is the potential that this offers a residual safety value under certain crash conditions. Posts are typically lightweight and can be installed in cast or driven sockets in the ground to facilitate removal and replacement. One disadvantage is that each vendor uses a different post design and cable arrangement, and therefore posts are not interchangeable between systems manufactured by different vendors.

The Department has used High Tension Cable Barrier in selected locations and continues to install these systems using the Department's Developmental Design Standard and Developmental Specifications

process. Detailed information on the usage requirements and design criteria of HTCB can be found on the **Department's DDS** website

<http://www.dot.state.fl.us/rddesign/DS/Dev.shtm>.

It includes the following:

Instructions for Developmental Design Standards (IDDS), D450

Developmental Design Standards (DDS) Index D450

Developmental Specification, Dev540

When considering the use of a Developmental Design Standards device, review FDOT's Developmental Design Standards Usage Process included on the DDS Website (<http://www.dot.state.fl.us/rddesign/DS/Dev/Developmental-Design-Standards-Usage-Process.pdf>).

E.6.d Temporary Barrier

As stated in Section E.5.e, temporary barriers are used primarily in work zones for several purposes. The most commonly used temporary barriers in Florida are those adopted for use by FDOT. FDOT temporary barriers include:

Low Profile Barrier – Design Standards, Index 412 (TL-2, NCHRP 350)

Type K Barrier – Design Standards, Index 414 (TL-3, NCHRP 350)

Proprietary Temporary Barrier – Design Standards, Index 415 & APL (TL-2 & TL-3, NCHRP 350)

Additional information on the proper use of these barriers is provided in the FDOT Plans Preparation Manual and the Vendor drawings on the FDOT Approved Product List.

Additional information on temporary barrier systems meeting NCHRP Report 350 and/or MASH criteria can be found in the following documents:

E.6.e Selection Guidelines

The evaluation of numerous factors is required to ensure that the appropriate barrier type is selected for a given application. Consideration should be given to the following factors when evaluating each particular site:

- Barrier Placement requirements (see Section E.6.f)
- Traffic characteristics (e.g. vehicles types/percentages, volume, and growth)
- Site characteristics (e.g. terrain, alignment, geometry, access facility type, access locations, design speed, etc.)
- Expected frequency of impacts
- Initial and replacement/repair costs
- Ease of maintenance
- Exposure of workers when conducting repairs/maintenance
- Aesthetics

For additional information about considerations for barrier selections refer to the AASHTO RDG. Barrier type selection decisions and warrants should be documented.

E.6.f Placement

E.6.f.1 Barrier Offsets

Roadside barriers should be offset as far from the travel lanes as practical with consideration for maintaining the proper performance of the barrier. For FDOT barriers described above see the FDOT Plans Preparation Manual and Design Standards for proper barrier placement. **Figure 4 – 8 Sidewalk with Guardrail provides information on the offset of guardrail on curb and gutter and flush shoulder roadways.**

Figure 4 – 8 Sidewalk with Guardrail

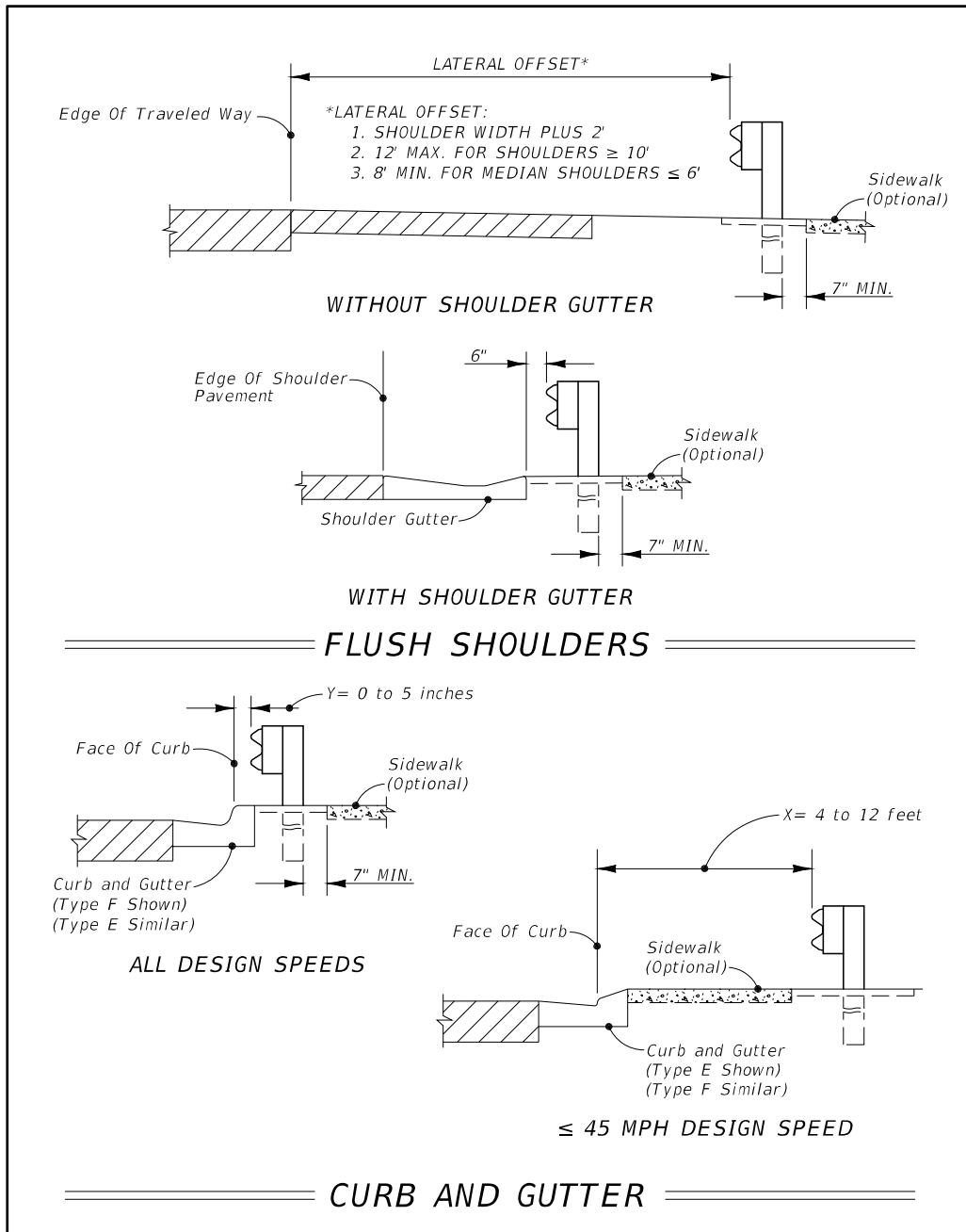

E.6.f.2 Deflection Space and Zone of Intrusion

In addition to travel lane lateral offset considerations, an adequate setback must be provided behind the barrier to ensure proper function. For flexible and semi-rigid barriers the setback is based on deflection tolerances and is required to prevent the barrier from contacting aboveground objects.

For rigid barriers the setback is required to keep the area above and behind the barrier face free of obstructions that could penetrate or damage the vehicle compartment. This requirement is based on the Zone of Intrusion (ZOI) concept as described in the **AASHTO Roadside Design Guide**.

Table 4 – 6 Minimum Barrier Setback provides the setback requirements for the Department’s standard barriers. Additionally, Figure 4 – 9 Setback Distances for Discontinuous Elements includes setback distances to rigid barriers for discontinuous elements. These requirements do not apply to devices located within the setback distance detailed in the Department’s **Design Standards** (e.g. pedestrian/bicycle railing, fencing, noise walls, etc.).

For Department barriers described above see the Department’s **Plans Preparation Manual** and **Design Standards** for proper barrier setback.

**Table 4 – 6 Minimum Barrier Setback
 (Measured from the face of the barrier)^(KM261)**

**Table 4.4.2 Minimum Barrier Setback
 (Measured from the face of the barrier)**

Barrier Type	Setback Distance
Flexible Barrier	
High Tension Cable Barrier (HTCB)	12'-0"
Semi-Rigid Barrier	
W-Beam with Post Spacing @ 6'-3" (TL-3)	5'-0"
W-Beam with Post Spacing @ 12'-6" (TL-2)	5'-0"
W-Beam with Post Spacing @ 3'-1½" (½ Spacing)	3'-10"
W-Beam with Post Spacing @ 1'-6¾" (¼ Spacing)	3'-2"
Nested W-Beams with Post Spacing @ 3'-1½" (½ Spacing)	3'-0"
Nested W-Beams with Post Spacing @ 1'-6¾" (¼ Spacing)	2'-8"
Deep Post W-Beam installed on 1:2 Slope Break with Post Spacing @ 6'-3" (TL-3)	5'-6"
Modified Thrie-Beam with Post Spacing @ 6'-3"	3'-0"
Rigid-Barrier	
Concrete Barrier < 40" Height Non-crash Tested Continuous or Discontinuous Items	1'-6"
Concrete Barrier ≥ 40" Height Non-crash Tested Continuous or Discontinuous Items	0'-0"
Bridge Traffic Railing < 40" Height Non-crash Tested Continuous Items	5'-0"
Non-crash Tested Discontinuous Items	See Figure 4.4.13
Temporary Barriers See "Deflection Space" of applicable <i>Design Standards, Index</i> or <i>APL</i> drawing.	

Figure 4 – 9 Setback Distances for Discontinuous Elements^[KM27]

Figure 4.4.13 Setback Distances for Discontinuous Elements

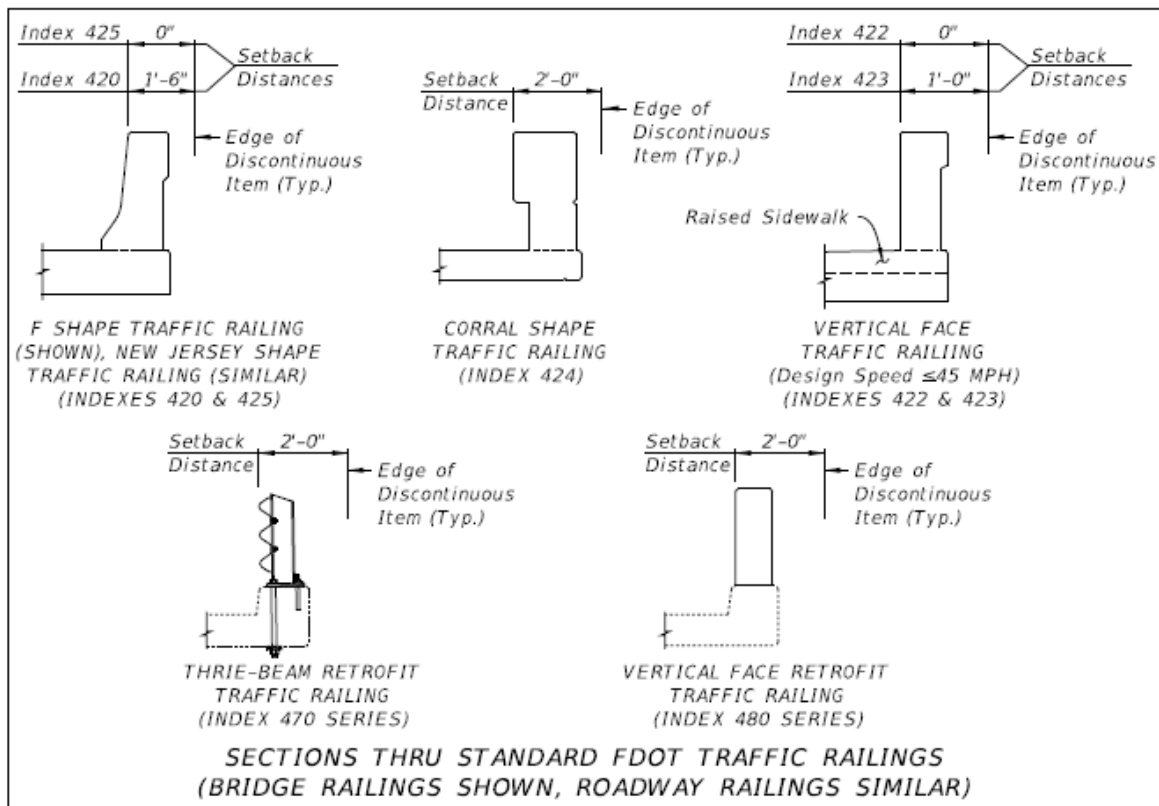

E.6.f.3 Grading

The terrain effects between the traveled way and a barrier can have a significant impact on whether or not a barrier will perform as intended. Proper grading around a barrier will ensure that as a vehicle approaches a barrier its suspension is not dramatically affected, causing the vehicle to underide or override a barrier.

For Department barriers described above see the Department's **Plans Preparation Manual** and **Design Standards** for grading requirements.

E.6.f.4 Curbs

As with grading, the presence of curb in combination with barriers deserves special attention. A vehicle which traverses a curb prior to impact may override the barrier if it is partially airborne at the moment of impact. Conversely, the vehicle may "submarine" under the rail element of a guardrail system and snag on the support posts if it strikes the barrier too low.

For the Department's barriers described above, see the Department's *Design Standards* and *Plans Preparation Manual* for proper placement with respect to curbs.

E.6.f.5 Flare Rate

A flared roadside barrier is when it is not parallel to the edge of the traveled way. A flared barrier may be necessary for several reasons:

- To locate the barrier terminal farther from the roadway
- To minimize a driver's reaction to an obstacle near the road by gradually introducing a parallel barrier installation
- To transition a roadside barrier to an obstacle nearer the roadway such as a bridge parapet or railing
- To reduce the total length barrier needed.
- To reduce the potential for barrier and terminal impacts and provide additional roadside space for an errant motorist to recover.

A concern with flaring a section of roadside barrier is that the greater the flare rate, the higher the angle at which the barrier can be hit. As the angle of impact increases, the crash severity increases, particularly for rigid and semi-rigid barrier systems. Another disadvantage to flaring a barrier installation is the increased likelihood that a vehicle will be redirected back into or across the roadway following an impact.

For the Department's barriers described above, see the Department's *Design Standards* and *Chapter 4* of the *Plans*

Preparation Manual for acceptable flare rates. Additional information on flare rates are provided in the **AASHTO Roadside Design Guide**.

E.6.f.6 Length of Need^[KM28]

The length of need for a particular barrier type is calculated based on a number of factors including the length of the hazard, the lateral area of concern, runout length and other factors. Length of need must consider traffic from both directions.

A spreadsheet tool for calculating length of need is provided on the Department's **Design Standards** web page, adjacent to Index 400 in the Design Tools column. Additional information on length of need is provided in the **Roadside Design Guide**.

E.6.g Barrier Transitions

Guardrail transitions are necessary whenever standard W-Beam guardrail converges with rigid barriers. The purpose of the transition is provide a gradual stiffening of the overall approach to a rigid barrier so that vehicular pocketing, snagging, or penetration is reduced or avoided at any position along the transition. Guardrail transitions must include sound structural connections, nested panels and additional posts for increased stiffness. The Department's **Design Standards** provide details for several transitions for both permanent and rigid barriers that meet MASH criteria. Additional information on transitions is provided in the Department's **Plans Preparation Manual** and the **AASHTO Roadside Design Guide**.

E.6.h Attachments to Barriers

Attachments to barriers such as signs, light poles, and other objects will affect crash performance and should be avoided where practical. Attachments not meeting the requirements discussed in E.6.f Placement, should meet crash test criteria. See the Department's **Plans Preparation Manual** for additional direction on attachments to barriers.

E.7 End Treatments and Crash Cushions

As previously discussed, end treatments include end anchorages, end terminals, and crash cushions. Details for end treatments for each barrier type described above are detailed in the Department's ***Design Standards*** and the Department's ***Approved Products List***.

E.7.a End Treatments for Guardrail

End treatments for guardrail are categorized as follows:

1. Approach end terminals – required for guardrail ends within the clear zone of approaching traffic. The Department's guardrail approach end terminals are proprietary devices listed on ***Approved Products List (APL)***. Approach end terminals are classified by Test Level (TL-2 for Design Speeds ≤ 45 mph or TL-3, which is acceptable for all Design Speeds) and as follows:
 - a. Flared – preferred terminal for locations where sufficient space is available to offset barrier end from approaching traffic.
 - b. Parallel – use only when sufficient space is not available for a flared terminal.
 - c. Double Face – preferred end treatment for double faced guardrail installations.
2. Crash Cushions – See Section E.7.e.
3. Trailing End Anchorages (Type II) – required for anchoring of the trailing ends of guardrail. Trailing End Anchorages are considered non-crashworthy as an approach end treatment, and are not permitted as a guardrail end treatments on the approach end within the Clear Zone, unless shielded by another run of barrier. The Department's Type II Trailing End Anchorage, is detailed in the ***Design Standards, Index 400***.

Additional information on guardrail end treatments is provided in the Department's ***Plans Preparation Manual***.

E.7.b End Treatments for Rigid Barrier

Rigid Barrier ends must be terminated by either transitioning into another barrier system (e.g. guardrail), or by shielding with a Crash Cushion. Details are provided in the Department's **Design Standards**. Treatment of the trailing end of rigid barriers is not required unless additional hazards exist beyond the rigid barrier or the barrier is within the clear zone of opposing traffic.

E.7.c End Treatments for High Tension Cable Barrier

End treatments for high tension cable barrier are vendor specific. For additional information regarding the end treatment of HTCB, refer to the Department's developmental design standards discussed above.

E.7.d End Treatments for Temporary Barrier

Details for end treatments for the Department's Temporary Barrier are provided in the Department's **Design Standards** and include:

1. Connecting to an existing barrier (Smooth, structural connections are required. Information on connections can be found in **Design Standards Indexes 410 and 414** and **APL**)
2. Shield end with a crash cushion as detailed in the **Design Standards** or **APL** for the specific type of Temporary Barrier (i.e. portable concrete barrier, Steel, or Water Filled)
3. Attaching or Transitioning to a crashworthy end treatment as described above
4. Flaring outside of the Work Zone Clear Zone

E.7.e Crash Cushions

Crash cushions are classified based on Test Level and Design Speed which is shown for each system on each vendor's respective drawings posted on the Department's **APL**.

The design of a crash cushion system must not create a hazard to opposing traffic. The APL drawings provide details for transitions for optional barrier types with and without bi-directional traffic.

An impacting vehicle should strike the systems at normal height, with the vehicle's suspension system neither collapsed nor extended. Therefore, the terrain surrounding crash cushions must be relatively flat (i.e. 1:10 or flatter) in advance of and along the entire design length of the system. Curbs should not be located within the approach area of a crash cushion.

The Department's *Plans Preparation Manual* provides additional information on permanent and temporary crash cushions.

F BRIDGE RAILS

See *Chapter 17 - Bridges and Other Structures* for requirements for bridge rails. The Department's *Plans Preparation Manual* may be referenced for additional information and typical applications.

GF REFERENCES FOR INFORMATIONAL PURPOSES

The following is a list of publications that may be referenced for further guidance:

- AASHTO Roadside Design Guide
<https://bookstore.transportation.org/>
- Task Force 13 Roadside Hardware Guide
<http://www.aashtotf13.org/>
- FHWA Web Site
http://safety.fhwa.dot.gov/roadway_dept/
- NCHRP Report 672 – Roundabouts: An Informational Guide, Second Edition
http://onlinepubs.trb.org/onlinepubs/nchrp/nchrp_rpt_672.pdf
- US Postal Service Mailbox Guidelines
<https://www.usps.com/manage/mailboxes.htm>
- Section 401, Florida Statutes
http://www.leg.state.fl.us/Statutes/index.cfm?App_mode=Display_Statute&Search_String=&URL=0300-0399/0337/Sections/0337.401.htm [KM29]
- FDOT Plans Preparation Manual
<http://www.fdot.gov/roadway/PPMManual/PPM.shtm>
- FDOT Design Standards
<http://www.fdot.gov/roadway/DesignStandards/Standards.shtm>
- FDOT Structures Design Guidelines
<http://www.fdot.gov/structures/StructuresManual/CurrentRelease/StructuresManual.shtm>
- FDOT Drainage Manual, January 2017
<http://www.fdot.gov/roadway/Drainage/ManualsandHandbooks.shtm>
- Florida Strategic Highway Safety Plan 2016 (Draft)
<http://www.fdot.gov/safety/SHSP2012/SHSP-2012.shtm>

CHAPTER 8

PEDESTRIAN FACILITIES

A	INTRODUCTION	8-1
B	TYPES OF PEDESTRIAN FACILITIES	8-1
	B.1 Sidewalks	8-1
	B.2 Shared Use Paths	8-3
	B.3 Shared Streets	8-3
	B.4 Shoulders	8-3
C	MINIMIZING CONFLICTS	8-4
	C.1 General Needs	8-4
	C.2 Horizontal Separation	8-4
	C.2.a General Criteria	8-4
	C.2.b Buffer Widths	8-5
	C.3 Other Considerations	8-6
D	BARRIER SEPARATION	8-7
	D.1 Longitudinal Barriers	8-7
	D.2 Fencing, Pedestrian Channelization Devices or Landscaping	8-9
E	GRADE SEPARATION	8-10
	E.1 Overpasses	8-11
	E.2 Underpasses	8-11
F	DROP-OFF HAZARDS FOR PEDESTRIANS	8-12
G	PEDESTRIAN CROSSINGS	8-14
	G.1 Crosswalks	8-14
	G.1.a Marked Crosswalks	8-14
	G.1.b Midblock Crosswalks	8-16
	G.2 Curb Ramps and Blended Transitions	8-19
	G.3 Detectable Warnings	8-20
	G.4 Controls	8-21
	G.5 Sight Distance	8-22

<u>G.6</u>	<u>Rail Crossings</u>	<u>8-22</u>
<u>H</u>	<u>LIGHTING</u>	<u>8-23</u>
<u>I</u>	<u>REFERENCES FOR INFORMATIONAL PURPOSES</u>	<u>8-25</u>
<u>A</u>	<u>INTRODUCTION</u>	<u>8-1</u>
<u>B</u>	<u>TYPES OF PEDESTRIAN FACILITIES</u>	<u>8-1</u>
B.1	Sidewalks	8-1
B.2	Shared Use Paths	8-3
B.3	Shared Streets	8-3
B.4	Shoulders	8-4
<u>C</u>	<u>MINIMIZING CONFLICTS</u>	<u>8-5</u>
C.1	General Needs	8-5
C.2	Horizontal Separation	8-6
C.2.a	General Criteria	8-6
C.2.b	Buffer Widths	8-7
C.3	Other Considerations	8-8
<u>D</u>	<u>BARRIER SEPARATION</u>	<u>8-9</u>
D.1	Longitudinal Barriers	8-9
D.2	Fencing, Pedestrian Channelization Devices or Landscaping	8-11
<u>E</u>	<u>GRADE SEPARATION</u>	<u>8-12</u>
E.1	Overpasses	8-13
E.2	Underpasses	8-13
<u>F</u>	<u>DROP-OFF HAZARDS FOR PEDESTRIANS</u>	<u>8-14</u>
<u>G</u>	<u>PEDESTRIAN CROSSINGS</u>	<u>8-16</u>
G.1	Crosswalks	8-16
G.1.a	Marked Crosswalks	8-16
G.1.b	Midblock Crosswalks	8-18
G.2	Curb Ramps	8-21
G.3	Controls	8-22
G.4	Sight Distance	8-22

G.5	Rail Crossings.....	8-23
H	LIGHTING.....	8-23
I	REFERENCES FOR INFORMATIONAL PURPOSES.....	8-25

FIGURES

Figure 8 – 1	Shoulder Point with Sidewalk.....	8-5
Figure 8 – 2	Sidewalk with Guardrail.....	8-8
Figure 8 – 3	Guardrail with Pipe Rail Detail	8-9
Figure 8 – 4	Pedestrian Bridge Typical Section	8-10
Figure 8 – 5	Drop-Off Hazards for Pedestrians and Bicyclists	8-13
Figure 8 – 6	Pedestrian Median Refuge with Curb Extension.....	8-15
Figure 8 – 7	Raised Midblock Crosswalk	8-17
Figure 8 – 8	Pedestrian Hybrid Beacon (PHB).....	8-18
Figure 8 – 9	Pedestrian Median Refuge with Rectangular Rapid Flashing Beacons	8-19
Figure 8 – 1	Shoulder Point with Sidewalk.....	8-7
Figure 8 – 2	Sidewalk with Guardrail.....	8-10
Figure 8 – 3	Guardrail with Pipe Rail Detail	8-11
Figure 8 – 4	Pedestrian Bridge Typical Section	8-12
Figure 8 – 5	Drop-Off Hazards for Pedestrians and Bicyclists	8-15
Figure 8 – 6	Pedestrian Median Refuge with Curb Extension.....	8-17
Figure 8 – 7	Raised Midblock Crosswalk	8-19
Figure 8 – 8	Pedestrian Hybrid Beacon (PHB).....	8-20

~~Figure 8-9~~ ⁹ ~~Pedestrian Median Refuge with Rectangular Rapid Flashing~~
~~Beacons~~ ~~8-21~~ ⁸⁻²¹

CHAPTER 8

PEDESTRIAN FACILITIES

A INTRODUCTION

Pedestrian facilities shall be given full consideration in the planning and development of transportation facilities, including the incorporation of such facilities into state, regional, and local transportation plans and programs under the assumption that transportation facilities will be used by pedestrians. Pedestrian facilities should be considered in conjunction with the construction, reconstruction, or other significant improvement of any transportation facility. Special emphasis should be given to projects in or within 1 mile of an urban area.

In addition to the design criteria provided in this chapter, the [2006 Americans with Disabilities Act Standards for Transportation Facilities](#) as required by [49 C.F.R 37.41 or 37.43](#) and the [2012 Florida Accessibility Code for Building Construction](#) as required by [61G20-4.002](#) impose additional requirements for the design and construction of pedestrian facilities. Examples of pedestrian facilities include sidewalks, shared use paths, over and under passes, curb ramps, median refuges, and crosswalks.

Each highway agency responsible for a system of streets and highways should establish and maintain a program for implementing pedestrian facilities, and for maintaining existing pedestrian facilities.

B TYPES OF PEDESTRIAN FACILITIES

There are several ways in which pedestrians can be accommodated in the public right of way

B.1 Sidewalks

Sidewalks are walkways parallel to the roadway and designed for use by pedestrians. Sidewalks should be provided along both sides of roadways that are in or within one mile of an urban area. If sidewalks are constructed on the approaches to bridges, they should be continued across the structure. If continuous sidewalks are constructed on only one side of the street, pedestrians should be provided access to facilities and services located on the opposite side

of the street. Newly constructed, reconstructed, or altered sidewalks shall be accessible to and usable by persons with disabilities.

The minimum width of a sidewalk shall be 5 feet on both curb and gutter and flush shoulder roadways. The minimum separation for a 5-foot sidewalk from the back of curb is 2 feet. If the sidewalk is located adjacent to the curb, the minimum width of sidewalk is 6 feet. For sidewalks not adjacent to the curb, at least a 1-foot wide graded area should be provided on both sides, flush with the sidewalk and having a maximum 1:6 slope. Wider sidewalks should be considered in Central Business Districts and in areas where heavy two-way pedestrian traffic is expected.

A 5-foot wide (minimum) sidewalk that connects a transit stop or facility with an existing sidewalk or shared use path shall be included to comply with ADA accessibility standards. **Chapter 13 – Transit** provides illustrations of the connection between the sidewalk and transit facility.

Particular attention shall be given to pedestrian accommodations at the termini of each project. If full accommodations cannot be provided due to the limited scope or phasing of a roadway project or an existing sidewalk is not present at the termini, an extension of the sidewalk to the next appropriate pedestrian crossing or access point should be considered. If pedestrian facilities are provided, they shall be connected with facilities (e.g. sidewalks, shared use path, and crosswalks on the adjoining projects).

For new construction and reconstructed roadways, grades on sidewalks or shared use paths shall not exceed 5%, unless accessible ramps and landings are provided. However, in a roadway right of way, the grade of sidewalks or shared use paths is permitted to equal the general grade established for the adjacent street or highway. There should be enough sidewalk or path cross slope to allow for adequate drainage, however the maximum shall be no more than 2% to comply with ADA requirements.

Where existing physical constraints make it impracticable for altered elements, spaces, or facilities to fully comply with the requirements for new construction, compliance is required to the extent practicable within the scope of the project. Existing physical constraints include, but are not limited to, underlying terrain, right-of-way availability, underground structures, adjacent developed facilities, drainage, or the presence of a notable natural or historic feature.

Additional information on designing accessible pedestrian facilities is provided by the United States Access Board at the following web site:

<http://www.access-board.gov/guidelines-and-standards/streets-sidewalks/public-rights-of-way/proposed-rights-of-way-guidelines/major-issues>

Edge drop-offs should be avoided. When drop-offs cannot be avoided, they should be shielded as discussed in Section F, Drop-Off Hazards for Pedestrians.

For additional information concerning the design of sidewalks, refer to **Section C.7.d of Chapter 3 – Geometric Design**.

B.2 Shared Use Paths

Paths are usually set back from the road and separated by a green area, ditch, swales or trees. Shared use paths are intended for the use by both pedestrians and bicyclists and shall be accessible. For additional information concerning the design of shared-use paths, refer to **Chapter 9 - Bicycle Facilities**.

B.3 Shared Streets

Shared uses of a street for people walking, bicycling and driving are referred to as shared streets. These are usually specially designed spaces such as pedestrian streets which are local urban streets with extremely low vehicle speed.

B.4 Shoulders

Highway shoulders are –not intended for frequent use by pedestrians, but do accommodate occasional pedestrian traffic. Highway shoulders often have cross slopes which exceed 2%; consequently they are not considered or expected to fully meet ADA criteria.

C MINIMIZING CONFLICTS

The planning and design of new streets and highways shall include provisions that support pedestrian travel and minimize vehicle-pedestrian conflicts. These may include:

- Sidewalks and/or shared use paths parallel to the roadway
- Marked pedestrian crossings
- Raised median or refuge islands
- Pedestrian signal features such as pedestrian signal heads and detectors
- Transit stops and shelters

In some situations it may be possible to eliminate a vehicle-pedestrian conflict through close coordination with the planning of pedestrian facilities and activity outside of the highway right of way. Care should be exercised to ensure the elimination of a given conflict point does not transfer the problem to a different location. Any effort to minimize or eliminate conflict points must consider the mobility needs of the pedestrian. The desired travel path should not be severed and the number of required crossing points and/or walking distances should not be significantly increased. Some crossings should be redesigned rather than eliminated or relocated.

C.1 General Needs

Minimizing vehicle-pedestrian conflicts can be accomplished by providing adequate horizontal, physical, or vertical (primarily for crossings) separation between the roadway and the pedestrian facility.

C.2 Horizontal Separation

The development of independent systems for pedestrian and motor vehicular traffic is the preferred method for providing adequate horizontal separation.

C.2.a General Criteria

New sidewalks should be placed as far from the roadway as practical in the following sequence of desirability:

1. As near the right of way line as possible. (ideally, 3 feet of width should be provided behind the sidewalk for above ground utilities)

2. Outside of the clear zone.
3. Sufficiently off-set from the curb to allow for the placement of street trees, signs, utilities, parking meters, benches or other street furniture outside of the sidewalk in urban locations (e.g. town center, business or entertainment district).
4. Five feet from the shoulder point on flush shoulder roadways.
5. At the grass shoulder point of flush shoulder roadways.

Figure 8 – 1 Shoulder Point with Sidewalk provides an illustration of the location of the shoulder point.

On arterial or collector roadways, sidewalks shall not be constructed contiguous to the roadway pavement, unless a curb or other barrier is provided. Nearing intersections, the sidewalk should be transitioned as necessary to provide a more functional crossing location that also meets driver expectation. Further guidance on the placement of stop or yield lines and crosswalks is provided in the [MUTCD, Part 3](#).

Figure 8 – 1 Shoulder Point with Sidewalk

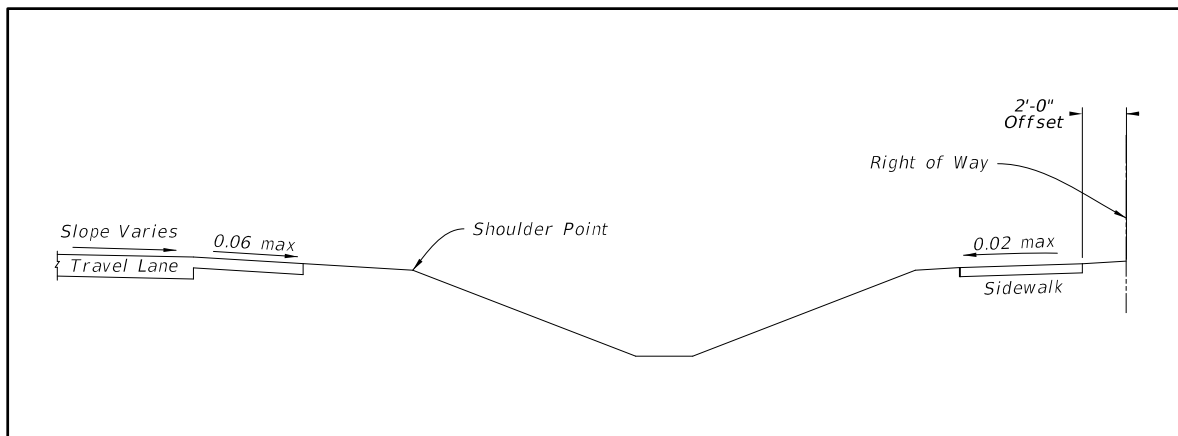

C.2.b Buffer Widths

Providing a buffer can improve pedestrian safety and enhance the overall walking experience. Buffer width is defined as the space between the sidewalk and the edge of traveled way. On-street parking or bike lanes can

also act as an additional buffer. The planting strip or buffer strip should be 6 feet where practical to eliminate the need to narrow or reroute sidewalks around driveways. With this wider buffer strip, the sidewalk is placed far enough back so that the driveway slope does not have to encroach into the sidewalk.

C.3 Other Considerations

When designing urban highways, the following measures may be considered to help increase the safe and efficient operation of the highway for pedestrians:

- Use narrower lanes and introduce raised medians to provide pedestrian refuge areas
- Provide pedestrian signal features and detectors
- Prohibit right turn on red
- Control, reduce, or eliminate left and/or right turns
- Prohibit free flow right turn movements
- Reduce the number of lanes

D BARRIER SEPARATION

Barriers may be used to assist in the separation of motor vehicular and pedestrian traffic.

D.1 Longitudinal Barriers

Longitudinal barriers such as guardrails, rigid barriers, and bridge railings are designed primarily to redirect errant vehicles away from roadside hazards. These barriers can also be used to provide valuable protection of pedestrian facilities from out of control vehicles.

Where adequate horizontal separation is not feasible, or where there is a significant hazard from out of control vehicles, longitudinal barriers may be utilized. If electing to use barriers, special consideration should be made to ensure proper sight distance near driveways and intersections is maintained. Figure 8 – 2 Sidewalk with Guardrail illustrates the correct placement of a sidewalk in conjunction with a guardrail.

When a sidewalk or shared use path is within 4 feet of the back of a guardrail with steel posts, a pipe rail should be installed on the back of the post. For a guardrail with timber posts, the bolt ends should be trimmed flush with the post or recessed. See Figure 8 – 3 Guardrail with Pipe Rail Detail for an illustration of when a pipe rail is needed. Additional information on the design of guardrails adjacent to a sidewalk or shared use path can be found in the [FDOT Design Standards, Index 400](#).

Figure 8 – 2 Sidewalk with Guardrail

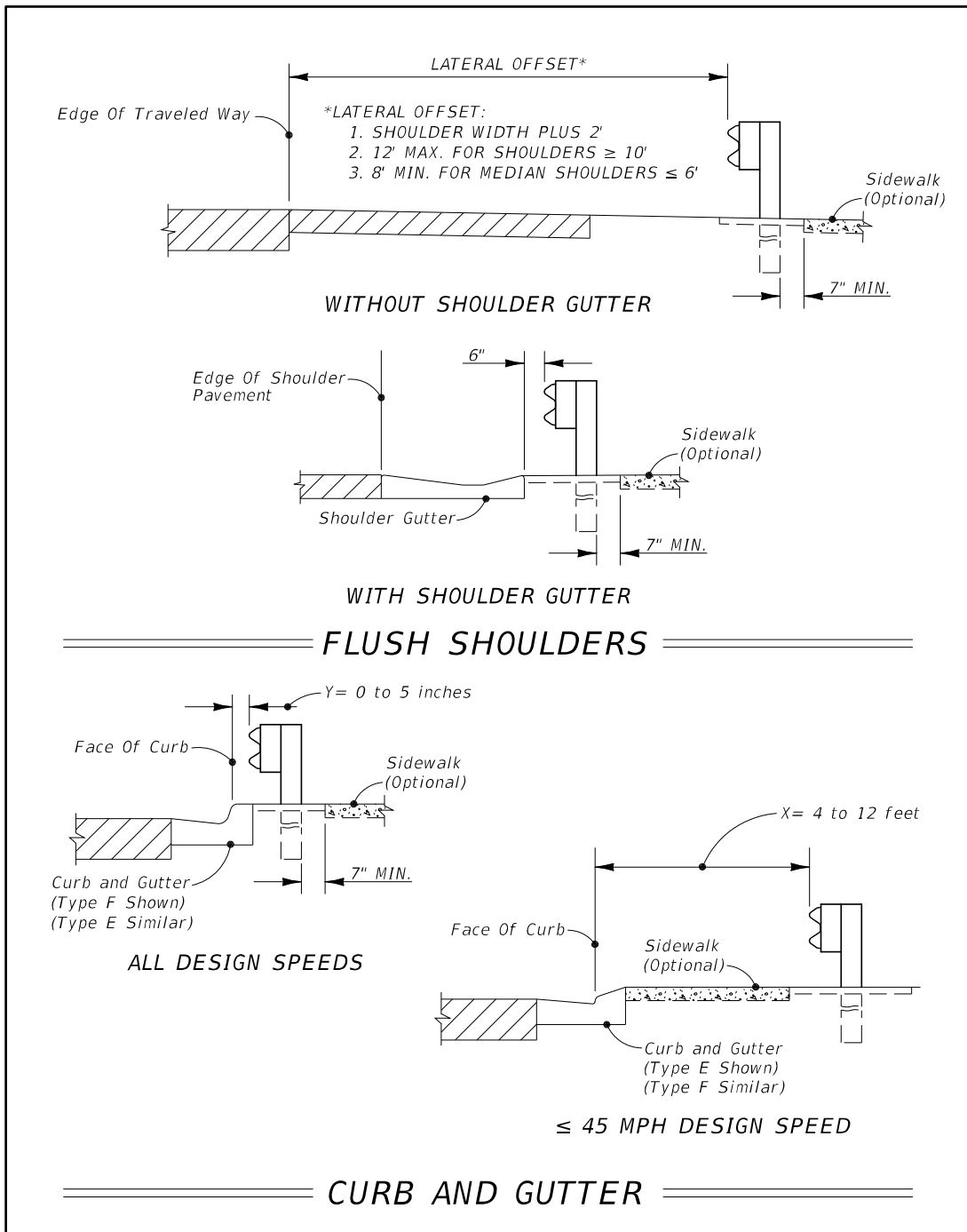
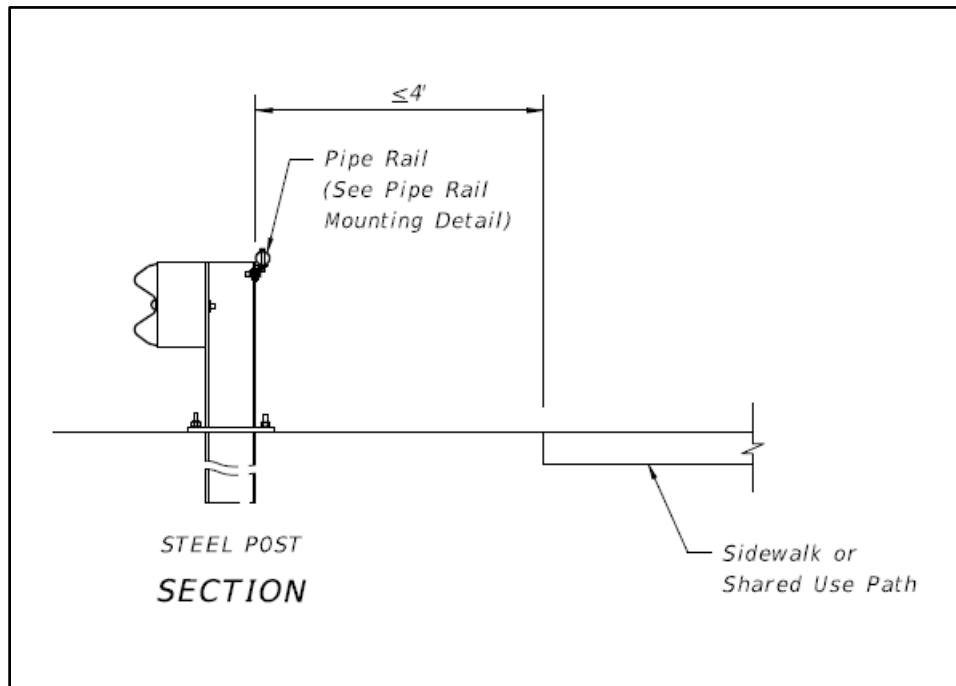

Figure 8 – 3 Guardrail with Pipe Rail Detail



D.2 Fencing, Pedestrian Channelization Devices or Landscaping

Fencing, pedestrian channelization devices or landscaping may be used to discourage pedestrian access to the roadway and aid in channeling pedestrian traffic to the proper crossing points. These should not be considered a substitute for longitudinal barriers, but may be used in conjunction with redirection devices.

E GRADE SEPARATION

Grade separation may be selectively utilized to support the crossing of large pedestrian volumes across highways where the traffic volume on the roadway is at or near capacity or where speeds are high. Overpasses or underpasses may be justified at major pedestrian generators such as schools, shopping centers, sports and amusement facilities, transit centers, commercial buildings, parks and playgrounds, hospitals, and parking facilities.

The minimum clear width of any stand-alone pedestrian overpass or underpass on a pedestrian accessible route is 8 feet. However, if the contiguous sidewalk or path is greater than 8 feet wide, the clear width of the overpass or underpass should match that width. The minimum clear height of a pedestrian overpass or underpass is 8 feet. See Figure 8 – 4 for an example of a pedestrian bridge typical section.

The [FDOT Structures Manual - Volume 1 - Structures Design Guidelines \(SDG\), Section 10](#) provide additional guidance on engineered steel and concrete pedestrian bridges.

Figure 8 – 4 Pedestrian Bridge Typical Section

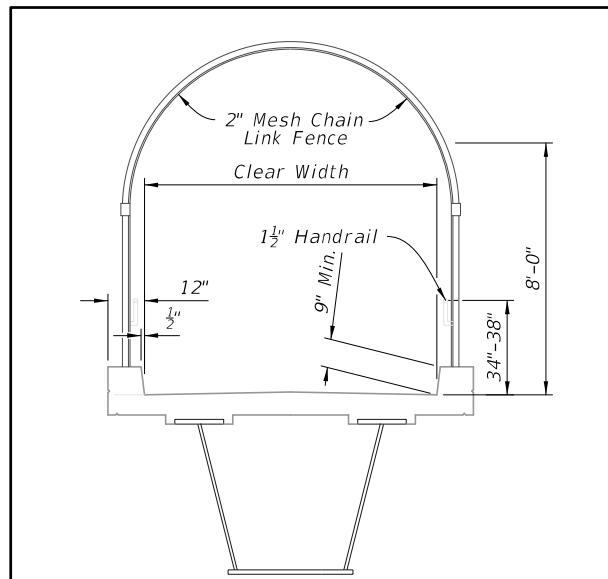

Notes: 1. Pedestrian handrails may be required. See the [2006 Americans with Disabilities Act Standards for Transportation Facilities](#).

2. Other superstructure configurations may be used provided an 8 ft. minimum headroom is maintained.

E.1 Overpasses

Pedestrian overpasses are typically bridge structures over major roadways or railroads. Overpasses should provide elevator access if they are not designed to provide accessible ramps with compliant slopes, level landings, and handrails on both sides. Bridges over roadways should be covered or screened to reduce the likelihood of objects being dropped or thrown below. The area adjacent to overpasses may be fenced to prevent unsafe crossings and to channel pedestrians to the overpass structure.

E.2 Underpasses

Pedestrian underpasses or tunnels perform the same function as overpasses. Their use is convenient when the roadway is elevated above the surrounding terrain.

Underpasses should be adequately maintained to reduce potential problems in lighting, cleaning, policing, and flooding and to maximize safety. The area adjacent to underpasses may be fenced to prevent unsafe crossings and to channel pedestrians to the underpass structure.

F DROP-OFF HAZARDS FOR PEDESTRIANS

Drop-off hazards are defined as steep or abrupt downward slopes that can be perilous to pedestrians and bicyclists. Consider shielding any drop-off determined to be a hazard. Care should be taken when using Pedestrian/Bicycle Railings or fencing near intersections or driveways as they could obstruct the driver's line of sight. To reduce the need for railings as a sidewalk or shared use path approaches an intersection, consider extending cross drains and side drains to minimize drop-offs.

There are two cases that require shielding as shown in Figure 8 – 5 Drop-Off Hazards for Pedestrians and Bicyclists. Depending on the depth of the drop-off and severity of the conditions below, shielding may be necessary for cases other than described above.

Railings or fences should be provided for vertical drop-off hazards or where shielding is required. The standard height for a pedestrian/bicycle railing is 42 inches. A 48 inch tall pedestrian/bicycle railing should be used when sidewalk grades are steeper than 5% and bicycle travel is expected. A standard railing is generally intended for urbanized areas, locations attaching to bridge rail or along concrete walkways. Fencing is generally intended for use in rural areas along paths and trails.

Figure 8 – 5 Drop-Off Hazards for Pedestrians and Bicyclists

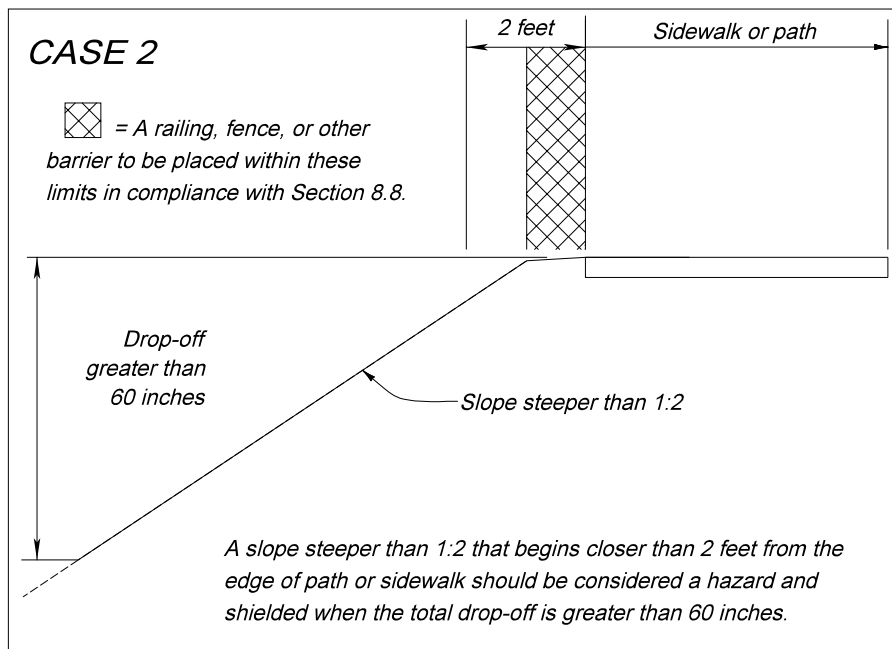
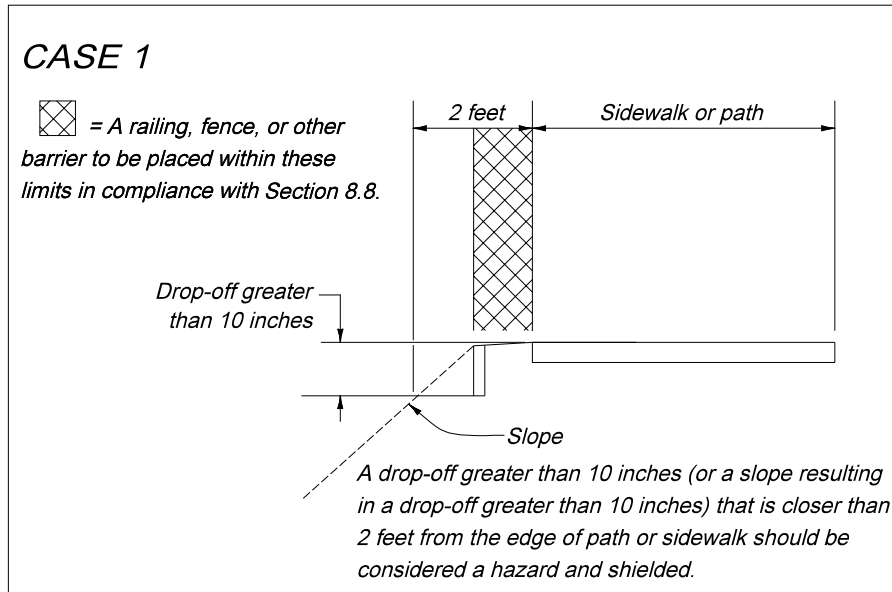

G PEDESTRIAN CROSSINGS

The design of pedestrian crossings and parallel pathways within the right of way shall be considered an integral part of the overall design of a street or highway.

The development of protection at any remaining crossings or conflict points must be adequate to achieve a total pedestrian transportation mode that is reasonably safe.

G.1 Crosswalks

The design of pedestrian crosswalks should be based on the following requirements:

- Crosswalks should be placed at locations with sufficient sight distances
- At crossings, the roadway should be free from changes in alignment or cross section
- The entire length of crosswalk shall be visible to drivers at a sufficient distance to allow a stopping maneuver
- Stop bars or yield markings, in conjunction with the appropriate signing, shall be provided at all marked crosswalks
- Crosswalks shall be easily identified and clearly delineated, in accordance with the [Manual on Uniform Traffic Control Devices \(MUTCD\) and Rule 14-15.010, F. A. C.](#)

G.1.a Marked Crosswalks

Marked crosswalks are one tool to allow pedestrians to cross the roadway safely. They are often used in combination with other treatments (signs, flashing beacons, curb extensions, pedestrian signals, raised median or refuge islands, and enhanced overhead lighting). Marked crosswalks serve two purposes: 1) to inform motorists of the location of a pedestrian crossing so that they have time to lawfully yield to or stop for a crossing pedestrian; and 2) to assure the pedestrian that a legal crosswalk exists at a particular location. See Figure 8 – 6 Pedestrian Median Refuge with Curb Extensions for an example of a pedestrian median refuge with a curb extension.

Figure 8 – 6 Pedestrian Median Refuge with Curb Extension



Urban Street Design Guide, National Association of City Transportation Officials (NACTO)

Marked crosswalks on an uncontrolled leg of an intersection or a mid-block location shall be supplemented with other treatments (such as signing, beacons, curb extensions, raised medians, raised traffic islands, or enhanced overhead lighting) when any of the following conditions exist:

1. Where posted speeds are greater than 40 mph.
2. On a roadway with 4 or more lanes without a raised median or raised traffic island that has an ADT of 12,000 or greater.
3. On a roadway with 4 or more lanes with a raised median or raised traffic island that has or is projected to have (within 5 years) an ADT of 15,000 or greater.

See **Chapter 6 – Lighting** for information on illuminating crosswalks and pedestrian facilities.

Additional guidance on marked crosswalks can be found in the [**AASHTO Guide for the Planning, Design, and Operation of Pedestrian Facilities**](#) and [**FHWA's Safety Effects of Marked vs. Unmarked Crosswalks at Uncontrolled Locations: Executive Summary and Recommended Guidelines**](#).

Marked crosswalks can also be used to create midblock crossings.

G.1.b Midblock Crosswalks

Midblock crosswalks facilitate crossings to places that people want to go but that are not well served by the existing sidewalk or path network. These pedestrian crossings commonly occur at schools, parks, museums, waterfronts, and other destinations. Designers should study both existing and projected pedestrian volumes in assessing warrants for midblock crossings to account for latent demand.

Midblock crossings are located according to a number of factors including pedestrian volume, traffic volume, roadway width, traffic speed and type, desired paths for pedestrians, land use, and to accommodate transit connectivity. Midblock crossings should not be installed where sight distance or sight lines are limited for either the motorist or pedestrian.

Midblock crossings should be marked and signed in accordance with the [MUTCD](#). See Figure 8 – 7 Raised Midblock Crosswalks for an example of a midblock crosswalk.

Figure 8 – 7 Raised Midblock Crosswalk



Suwannee Street, Tallahassee, Florida

Crosswalks may be supplemented with Pedestrian Hybrid Beacons (PHB) or Rectangular Rapid Flashing Beacons (RRFBs). Illumination should be evaluated if night-time pedestrian activity is expected. See **Chapter 6 – Lighting** for further information.

A PHB is a special type of beacon used to warn and control traffic at an unsignalized location to assist pedestrians in crossing a street or highway at a marked crosswalk. [Chapter 4F. Pedestrian Hybrid Beacons, MUTCD](#) provides additional information regarding their installation. See Figure 8 – 8 Pedestrian Hybrid Beacon for an example of a pedestrian hybrid beacon.

http://mutcd.fhwa.dot.gov/kno_2009r1r2.htm

Figure 8 – 8 Pedestrian Hybrid Beacon (PHB)



16th Street South, St. Petersburg, Florida

The RRFB uses rectangular-shaped high-intensity LED-based indications, flashes rapidly in a wig-wag "flickering" flash pattern, and is mounted immediately between the crossing sign and the sign's supplemental arrow plaque. Use of PHBs should be limited to locations with the most critical safety concerns, such as pedestrian and school crosswalks across uncontrolled approaches. The *MUTCD* provides further information on obtaining [interim approval](#) for the use of [RRFBs](#). See Figure 8 – 9 Pedestrian Median Refuge with Rectangular Rapid Flashing Beacon for an example of a Rectangular Rapid Flashing Beacon (RRFB).

http://mutcd.fhwa.dot.gov/res-interim_approvals.htm

**Figure 8 – 9 Pedestrian Median Refuge with
Rectangular Rapid Flashing Beacons**



4th Street North, St. Petersburg, Florida

G.2 Curb Ramps and Blended Transitions^[KM1]

A continuous accessible pedestrian route, including curb ramps and blended transitions such as depressed corners, raised street crossings, or flush roadway connections is needed along pedestrian networks. Include sidewalk curb ramps at the following locations:

- All intersections and turnouts with curbed returns. Include a landing at the top of each ramp.
- On curbed roadways between intersections where a crosswalk has been established

Relocate or adjust pull boxes, manholes and other types of existing surface features to meet the ADA requirements for nonslip top surfaces, ¼ inch height

protrusion, and slopes flush with the surrounding surface.

Curb ramps should be in line with the crossing. At intersections where more than one road is crossed, provide curb ramps at both ends of each crossing. Crossings are required to meet the same grade and cross slope requirements as sidewalks. Where criteria for maximum cross slope cannot be met, provide the minimum attainable cross slope. When following the profile grade of the roadway, curb ramp slopes should not exceed 15 feet in length.^[KM2]

Evaluate existing driveways and turnouts for compliance to ADA requirements. Nonconforming driveways are not required to be upgraded if it is not feasible within the scope of the project.

Provide transition slopes (flared sides) where a pedestrian circulation path crosses the curb ramp. The maximum slope of transition slopes is 1:10, measured parallel with and adjacent to the curb line.

When altering an existing pedestrian facility and conditions preclude the accommodation of a curb ramp slope of 1:12, provide a slope from 1:12 to 1:10 with a maximum rise of 6 inches.

Further information on curb ramps, landings and blended transitions are provided in the Department's *Design Standards Index 304*.^[KM3]

G.3 Detectable Warnings

Install detectable warnings to cover the full width of the walking surface and 2 feet deep. They are required on sidewalks and shared use paths at the following locations:

- curb ramps and blended transitions at street crossings
- cut-through pedestrian refuge islands or medians six feet wide or greater
- pedestrian at-grade rail crossings
- commercial driveways with a stop sign, yield sign or traffic signal

- boarding and alighting areas adjacent to the roadway at bus stops where there is an at-grade connection to the roadway
- edges of rail boarding platforms not protected by screens or guards

Detectable warnings are not required where sidewalk intersects urban flared turnouts or sidewalks that run continuously through driveways. Do not place detectable warnings on transition slopes or over grade breaks.

The detectable warning systems on the APL are designed to work with concrete surfaces. In areas where the pedestrian facility has an asphalt surface, such as a shared use path, specify an appropriate detectable warning system. In these cases, consider including a short section of concrete that will accommodate any system.

Further information on detectable warnings is provided in the Department's *Design Standards Index 304*.^[KM4]

~~Curb ramps provide access between the sidewalk and the street for people who use mobility aids such as wheelchairs or scooters, people pushing strollers and pulling suitcases, people on bicycles, and delivery services. Curb ramps and at grade connections from the sidewalk to the roadway shall include detectable warnings. Curb ramps shall be provided at all pedestrian crossings, including mid-block crossings and intersections to give persons with disabilities safe access. A level landing is necessary for turning, maneuvering, or bypassing the sloped surface~~

G.43 Controls

Signs, signals, and markings should be utilized to provide the necessary information and direction for pedestrians. All directions and regulations should be clear, consistent and logical, and should, at a minimum, conform to the requirements given in the MUTCD. The use of accessible pedestrian signals that include audible and/or vibro-tactile, and visual signals should be considered for pedestrian traffic control and regulation.

G.54 Sight Distance

The general requirements for sight distances for the driver are given in **Chapter 3 - Geometric Design**.

Stopping sight distances greater than the minimum should be provided at all pedestrian crossings. These sight distances should include a clear view of the pedestrian approach pathway for at least 15 feet from the outside travel lane. Where parallel pedestrian pathways are within the roadside recovery area, or where casual pedestrian crossings are likely, the normal required stopping sight distance should also include a clear view of the entire roadside recovery area.

Sight distances shall be based upon a driver's eye and object height as discussed in **Chapter 3 – Geometric Design**. Due to the small size of some pedestrians (particularly children), they are generally easy to confuse with other background objects.

Parking shall be prohibited where it would interfere with the required sight distance. Particular care should be exercised to ensure ample mutual sight distances are provided at all intersections and driveways.

G.65 Rail Crossings

Roadways, sidewalks and shared use paths at grade may cross light rail, surface commuter rail, conventional passenger rail, and freight railroads. Special design considerations are needed for these pedestrian intersections so that pedestrians are warned of the crossing and potential presence of a train. In addition, these crossings have specific accessibility requirements relating to surface continuity which must be met. See **Chapter 7 – Rail-Highway Crossings** for further information. The [Federal Railroad Administration](#) may impose additional requirements for the design and construction of rail crossings.

H LIGHTING

Lighting of the roadway itself is not only important for the safety of vehicular traffic, but also valuable for the protection of pedestrians. Vehicle headlamps often do not provide sufficient lighting to achieve the required stopping sight distance. Since this requirement is of vital importance at any potential pedestrian crossing point, lighting of the crossing should be considered. Lighting a street or highway is also valuable in improving the pedestrian's view of oncoming vehicles. At intersections or other locations with vehicle turning maneuvers, vehicle headlights may not be readily visible to the pedestrian.

Lighting shall be provided in pedestrian underpasses and should be considered on pedestrian overpasses. All pedestrian lighting shall be vandal resistant. The installation of daytime lighting is warranted when underpass user visibility requirements are not met with sunlight. Pedestrian underpass and overpass lighting should conform to the general lighting requirements given in the American Association of State Highway and Transportation Officials (AASHTO) Roadway Lighting Design Guide.

The general requirements for lighting on streets and highways are given in **Chapter 6 - Lighting**. Pathways adjacent to a street or highway should not be illuminated to a level more than twice that of the roadway itself.

In general, lighting should be considered as warranted when it is necessary, at night, to provide the mutual sight distance capabilities described in the preceding **Chapter 3 - Geometric Design**. Locations with significant night time pedestrian traffic that should be considered for lighting of the roadway and adjacent pedestrian facilities include the following:

- Any street or highway that meets the warranting criteria given in **Chapter 6 - Lighting**
- Streets and highways with speed limits in excess of 40 mph that do not have adequate pedestrian conflict elimination
- Sections of highway with minimal separation of parallel pedestrian pathways
- Intersections, access and decision points, and areas adjacent to changes in alignment or cross sections
- Areas adjacent to pedestrian generators
- Transit stops and other mass transit transfer locations
- Parking facilities

- Entertainment districts, sports/recreation complexes, schools, and other activity centers generating night travel
- Pedestrian crossings
- Any location where improvement of night time sight distance will reduce the hazard of vehicle-pedestrian conflicts

See **Chapter 6 – Lighting** for further information on lighting of pedestrian facilities and shared use paths.

I REFERENCES FOR INFORMATIONAL PURPOSES

- Florida Department of Transportation Transit Facility Design
<http://www.dot.state.fl.us/transit/Pages/NewTransitFacilitiesDesign.shtm>
- USDOT/FHWA ADA Standards for Accessible Design (ADAAG)
<http://www.access-board.gov/guidelines-and-standards/buildings-and-sites/about-the-ada-standards/ada-standards>
- 2006 Americans with Disabilities Act Standards for Transportation Facilities
<https://www.access-board.gov/guidelines-and-standards/transportation/facilities/ada-standards-for-transportation-facilities>
- 2012 Florida Accessibility Code for Building Construction
<https://www.flrules.org/gateway/ruleno.asp?id=61G20-4.002>
- AASHTO – Guide for the Planning, Design, and Operation of Pedestrian Facilities
<https://bookstore.transportation.org/>
- AASHTO – Roadway Lighting Design Guide |
<https://bookstore.transportation.org/>
- NACTO Urban Streets Design Guide
<http://nacto.org/usdg>
- Designing Walkable Urban Thoroughfares (CNU and ITE)
<http://www.cnu.org/streets>
- Project Management Handbook (CSS)
<http://www.dot.state.fl.us/projectmanagementoffice/Publications/default.shtm>
- FHWA Policy Memo for Flexibility in Pedestrian and Bicycle Facility Design
http://www.fhwa.dot.gov/environment/bicycle_pedestrian/guidance/design_guidance/design_flexibility.cfm
- AASHTO Load and Resistance Factor Design (LRFD) Bridge Design Specifications, 6^h Edition, (2012) with 2013 Interim Revisions
<https://bookstore.transportation.org/Home.aspx>
- Federal Railroad Administration General Manual - Policies, Procedures, and General Technical Bulletins (July 2014)
<http://www.fra.dot.gov/Elib/Details/L16208>

CHAPTER 14^[HMJ1]

DESIGN EXCEPTIONS AND VARIATIONS

A	GENERAL	14-1
B	RECOMMENDATIONS FOR APPROVAL	14-414-3
C	COORDINATION.....	14-514-4
D	JUSTIFICATION FOR APPROVAL	14-614-4
E	DOCUMENTATION FOR APPROVAL OF DESIGN EXCPETIONS	14-714-6
F	DOCUMENTATION FOR APPROVAL OF DESIGN VARIATIONS.....	14-1114-10
G	FINAL PROCESSING OF DESIGN EXCEPTIONS AND VARIATIONS... 14-12	14-11
A	GENERAL	14-1
B	RECOMMENDATIONS FOR AND APPROVAL OF DESIGN EXCEPTIONS .	14-2
C	COORDINATION OF DESIGN EXCEPTIONS	14-2
D	JUSTIFICATION AND DOCUMENTATION OF DESIGN EXCEPTIONS	14-3
E	FINAL PROCESSING OF DESIGN EXCEPTIONS	14-6

EXHIBITS

Exhibit 14-A	Sample Request Letter for Design Exception or Variation	14-1314-12
--------------	---------------------------------------------------------------	------------

CHAPTER 14

DESIGN EXCEPTIONS AND VARIATIONS

A GENERAL

Uniform minimum standards for design, construction, and maintenance ~~of~~ for streets and highways are contained in this Manual and meet or exceed the minimum values established by AASHTO. Consequently, the values given govern the design process. When it becomes necessary to deviate from the Manual's criteria, early documentation and approval are required.

Design Exceptions are required when proposed design elements are below both ^[KM2] AASHTO's new construction criteria and the criteria in this Manual for the following Controlling Design Elements ^[KM3].

The 10 Controlling Design Elements for high speed (Design Speed \geq 50 mph) roadways are:

- Design Speed
- Lane Width
- Shoulder Width
- Horizontal Curve Radius
- Superelevation Rate
- Stopping Sight Distance
- Maximum Grade
- Cross Slope
- Vertical Clearance
- Design Loading Structural Capacity

The 2 Controlling Design Elements for low speed (Design Speed $<$ 50 mph) roadways are:

- Design Speed
- Design Loading Structural Capacity

~~Documentation in the form of a Design Exception is required whenever any of the following 10 Controlling Elements, as identified by FHWA, cannot be met:~~

- ~~1. Design Speed (DS)~~
- ~~2. Lane Width (LW)~~

- ~~3. Shoulder Width (SW)~~
- ~~4. Horizontal Curve Radius (HCR)~~
- ~~5. Superelevation Rate (SR)~~
- ~~6. Stopping Sight Distance (SSD)~~
- ~~7. Maximum Grades (MG)~~
- ~~8. Cross Slope (CS)~~

Vertical Clearance (VC)

Design Loading Structural Capacity (DLSC)

When proposed design elements other than the Controlling Elements do not meet the criteria contained in this Manual, sufficient detail and justification of such deviations must be documented by the Responsible Professional Engineer as a Design Variation and submitted to the municipality or county.

Design Exceptions are required when any of the Manual's criteria for the 13 controlling Design Elements listed in Section B cannot be met. This chapter provides the process for documentation and approval of Design Exceptions and Variations. ~~When the Manual's criteria are met, no Design Exception is required. To expedite the approval of these deviations, it is important that to follow the correct approval process be followed. The design project file should~~ The approved Design Exception or Variation submittal should be included in the project file to clearly document the action taken and the approval given.

When proposed design elements other than the 13 controlling Design Elements do not meet the criteria contained in this Manual, sufficient detail and justification of such deviations shall be documented by the and provided to the maintaining agency. The level of detail included in the documentation is at the discretion of the maintaining agency.

B DESIGN EXCEPTIONS [HMJ4]

~~Design Exceptions are required when any of the Manual's criteria for the 13 controlling Design Elements listed below cannot be met.~~

~~9. Design Speed~~

~~10. Lane Widths~~

- ~~11. Shoulder Widths~~
- ~~12. Bridge Widths~~
- ~~13. Structural Capacity~~
- ~~14. Vertical Clearance~~
- ~~15. Grades~~
- ~~16. Cross Slopes~~
- ~~17. Superelevation~~
- ~~18. Horizontal Alignment~~
- ~~19. Vertical Alignment~~
- ~~20. Stopping Sight Distance~~
- ~~21. Horizontal Clearance~~
- 13. Lateral Offset

Projects that comply with ~~If the county or municipality has adopted by ordinance~~ design criteria for local subdivision roads and/or residential streets adopted by ordinance do not require a compliance with these regulations is an approved Design Exception or Variation^[KM5].

CB RECOMMENDATIONS FOR ~~AND APPROVAL OF DESIGN~~ ~~EXCEPTIONS~~^[KM6]

Design Exceptions and Variations are recommended by the Professional Engineer responsible for the project design elements (Responsible Professional Engineer). ~~A public or private utility may submit to the maintaining authority a completed exception package for work designed by the utility's forces~~^[KM7]. However, if the design is by others, the Design Exception package must be submitted, signed and sealed by a Professional Engineer licensed in the State of Florida. All Design Exceptions and Variations require approval from the ~~maintaining authority's (county or municipality)~~ designated Professional Engineer representative for the municipality or county with project oversight or general compliance responsibilities^[KM8].

Any Design Exception or Variation that involves a state facility or on the national highway system~~local~~^[KM9] facility must be processed through the Department's ~~local~~ district that has jurisdiction over the facility. The District Design Engineer ~~who~~ will then follow the Department's process as specified in Chapter 23 of the Department's *Plans Preparation Manual*^[KM10]. This process also includes the requirements for concurrence and approval by FHWA, when needed~~if necessary~~.

~~A public or private utility may submit to the municipal or county engineer a completed exception package for work designed by the utility's forces~~^[KM11]. However, if the design is by others, the Design Exception package must be submitted, signed and sealed by a Professional Engineer licensed in the State of Florida^[KM12]^[KM13]. The Department's *Utility Accommodation Manual* provides guidance on exceptions with respect to utilities located on state highway rights of way.

DC ~~COORDINATION OF DESIGN EXCEPTIONS~~

In order to allow time to research alternatives and begin ~~the~~ analysis and documentation activities, it is critical that Design Exceptions and Variations be identified as early in the process as possible. This is preferably done during the planning phases of projects or as soon as possible ~~in the~~ during initial design ~~efforts~~.

When the need for a Design Exception or Variation has been determined, the Responsible Professional Engineer must coordinate with the designated Professional Engineer representative of the municipality or county ~~maintaining authority~~ and the Department (if applicable), to obtain conceptual concurrence ~~providing and provide~~ any required-requested documentation. ~~requested.~~

~~The Department will be involved only if the proposed design on the local (Non-State Highway System (SHS)) roadway is part of a Department project. For example, a Department project for a roadway on the SHS includes work on the adjacent local roads, or a Department project is exclusively on a local (Non-SHS) roadway. In these cases, the District Design Engineer will be listed for "concurrence" in the Design Exception or Variation request letter, for "concurrence"~~ ^[KM14].

E

D **JUSTIFICATION FOR APPROVAL AND DOCUMENTATION OF DESIGN EXCEPTIONS** [KM15][KM16]

Sufficient detail and explanation must be given in order to justify approval to those reviewing the request. The 10 Controlling Design Elements are considered safety related and the strongest case possible must be made to lower these requirements. All deviations from criteria and standards in this Manual must be uniquely identified, located, and justified.

A strong case can be made if it can be shown that:

- The required criteria are not applicable to the site specific conditions.
- The project can be as safe by not following the criteria.
- The environmental or community needs prohibit meeting criteria.

Most often a case is made by showing the required criteria are impractical and the proposed design wisely balances all design impacts. The impacts required for documentation are:

- Safety and Operational performance
- Level of Service
- Right of Way impacts
- Community impacts
- Environmental impacts
- Costs
- Usability by all modes of transportation
- Long term and cumulative effects on adjacent sections of roadway

A case should not be made based solely on the basis that:

- The Department can save money.
- The Department can save time.
- The proposed design is similar to other designs.

E DOCUMENTATION FOR APPROVAL OF DESIGN EXCEPTIONS

Supporting documentation that is generated during the approval process is to accompany each submittal. Design Exceptions should include the following documentation:

1. Submittal/Approval Letter (Example shown in Exhibit 14-A)
2. Project Description:
 - a) General project information, location map, existing roadway characteristics, project limits (mileposts), county section number, work mix, objectives, and obstacles.
 - b) Associated or future limitations that exist as a result of public or legal commitments.
3. Project Schedule and Lifespan:
 - a) Letting date and other important production dates associated with the project.
 - b) Discussion of whether the deficiency is a temporary or permanent condition.
 - c) Future work planned or programmed to address the condition.
4. Exception Description:
 - a) Specific design criteria that will not be met (AASHTO, Florida Greenbook) and a detailed explanation of why the criteria or standard cannot be complied with or is not applicable.
 - b) Proposed value for the project or location and why it is appropriate.
 - c) Plan view, plan sheet, or aerial photo of the location, showing right of way lines and parcel lines of adjacent property.
 - d) Photo of the area of the deficiency.
 - e) Typical section or cross-section.
 - f) Milepost or station location.
5. Alternative Designs Considered:
 - a) Meeting AASHTO or Florida Greenbook criteria, partial correction, and the no-build (existing) condition.

6. Impacts of the Exception:

a) Safety Performance^[KM17]:

- Anticipated impact on safety, long and short term effects and of any anticipated cumulative effects.
- Summary of the most recent 5-year crash history including any pertinent crash reports.

b) Operational Performance:

- Description of the anticipated impact on operations (long and short term effects) and any anticipated cumulative effects.
- Summary of the amount and character of traffic using the facility.
- Compatibility of the design with adjacent sections of roadway.
- Effects on capacity and Level of Service (proposed criteria vs. AASHTO^[KM18])

c) Right-of-way

d) Community

e) Environment

f) Usability by all modes of transportation

7. Anticipated Costs:

- ### a) Description of the anticipated costs (design, right of way, construction, maintenance).

8. Mitigation Measures:

- ### a) Practical mitigation measures or alternatives that were considered and any selected treatments implemented on the project.

9. Summary and Conclusions

~~The objective of the justification of A Design Exception's justification is to demonstrate that the impacts on the operation and safety of the facility are acceptable as compared to the impacts and added benefits of meeting the criteria. All Design Exception requests shall include documentation sufficient to justify the request and independently evaluate the operational and safety impacts.~~

When preparing a Design Exception, the Responsible Professional Engineer should consider potential mitigation strategies that may reduce the adverse impacts to highway safety and traffic operations. Please refer to the FHWA *Mitigation Strategies for Design Exceptions (July 2007)* for provides the following examples of mitigation strategies.: The *Highway Safety Manual (HSM)* and *Highway Capacity Manual* provide information on quantifying and evaluating highway safety performance.

- Provide advance notice to the driver of the condition.
- Enhance the design of another geometric element to compensate for a potentially adverse action.
- Implement features designed to lessen the severity of an incident or action. [HSM 19]

Any request for a Design Exception request for a controlling design element should address the following issues applicable to the element in question:

Description:

- a) Project description (general information, typical section, etc.)
- b) Description of Design Exception (specific project conditions related to the Design Exception, controlling design element, acceptable Manual valuedesign criteria, and proposed value for project)
- c) The cCompatibility of the design and operation with the adjacent sections

Operational Impacts:

- a) Amount and character of traffic using facility
- b) Effect on capacity of the deviation (proposed criteria vs. Manual design criteria using an acceptable capacity analysis procedure and calculator determine the reduction for design year, level of service)

Safety Impacts:

- a) Crash history and analysis from most recent 5 years (location, type, severity, relation possibly attributable to the Design Exception element)
- b) Impacts associated with proposed criteria (annualized value of expected economic loss associated with crashes)

Benefit/Cost Analysis:

Calculate a benefit/cost analysis which estimates the cost effectiveness of correcting or mitigating a substandard design featureelement. The “benefit” is the expected reduction in future crash costs and the “cost” is the direct construction and maintenance costs associated with the design. These costs are calculated and annualized so that direct comparison of alternate designs can be made.

A benefit/cost ratio equal to or greater than 1.0 indicates it may be cost effective to implement a particular design; however, the final decision is a management decision which considers all factors and applies sound engineering judgement. The key factors in the analysis are:

- a) Evaluation of crashes by type and cause
- b) Estimate of crash costs (based on property damage and severity of injuries)
- c) Selection of a crash reduction factor based on proposed mitigation strategy
- d) Selection of a discount rate (typically 4% for roadway projects)
- e) Estimate of construction and maintenance costs
- f) Selection of service life of the improvements
- g) ~~Period of time over which the benefits will be realized~~

NOTE: ~~Chapter 2 of the AASHTO Roadside Design Guide and the FHWA Technical Advisory titled "Motor Vehicle Accident Costs" dated October 31, 1994,~~ Volume 1, Chapter 23 of the Department's Plans Preparation Manual provides guidance for the benefit/cost analysis, and may be usedconsidered. The Department provides a useful tool, BCAnalysis.xlsm, to aid in determining the benefit/cost ratio, that is available at the following website: <http://www.dot.state.fl.us/rddesign/QA/Tools.shtm>.

Conclusion and Recommendation:

- a) The cumulative effect of other deviations from design criteria
- b) Safety mitigating measures considered and provided
- c) Summarize specific course of action

F DOCUMENTATION FOR APPROVAL OF DESIGN VARIATIONS

When proposed design elements other than the Controlling Elements do not meet the criteria contained in this Manual, sufficient detail and justification of such deviations must be documented by the Responsible Professional Engineer as a Design Variation and submitted to the municipality or county. The documentation, submittal and approval requirements for Design Variations are similar to that for Design Exceptions described in this chapter.

Design Variations should include:

- a) Design criteria versus proposed criteria.
- b) Reason the design criteria are not appropriate.
- c) Justification for the proposed criteria.
- d) Review and evaluation of the most recent 5 years of crash history where appropriate.
- e) Background information which documents or justifies the request.

GFE FINAL PROCESSING OF DESIGN EXCEPTIONS AND VARIATIONS

After receiving conceptual approval ~~has been obtained~~ from the designated Professional Engineer representative of the municipality or county, ~~maintaining authority's designee~~ and the documentation justifying the Design Exception or Variation shall be is signed and sealed by the Responsible Professional Engineer and delivered to the municipality or county, ~~and forwarded the submittal, as per the sample request letter~~. **ExhibitXHIBIT 14--A Sample Request Letter for Design Exception or Variation** provides an example of an appropriate format and should be included with the signed and sealed supporting documents. ~~to the maintaining authority's designated Professional Engineer~~, ~~t~~The Design Exception or Variation will be reviewed for completeness and adherence to the requirements of Sections D and E of, this Chapter.

If the Design Exception satisfies all requirements, the approval will be signed by the municipality's or County's maintaining authority's designated Professional Engineer representative; and, if applicable, forwarded to the Department's District Design Engineer for concurrence.

When all signatures are obtained, the Design Exception or Variation will be returned to the Responsible Professional Engineer. The original A copy will be retained by the municipality or County~~maintaining agency~~ and a copy kept by the Department, if applicable.

Exhibit 14-A Sample Request Letter for Design Exception or Variation

TO: _____

DATE: _____

SUBJECT: **DESIGN EXCEPTION** or **DESIGN VARIATION**

Local road number or street name: _____

Project description (limits): _____

Type construction (new, rehabilitation, adding lanes, resurfacing, etc.) _____

Design Speed _____

State and/or Federal road number (if applicable): _____

FDOT Financial Project ID No. (if applicable): _____

DESIGN EXCEPTION OR VARIATION FOR THE FOLLOWING ELEMENT:

- | | | | | |
|------------------------------------|------------------------------------|---------------------------|-----------------------------|-----------------|
| () Design speed | () <u>Stopping Sight Distance</u> | <u>Lane widths</u> | () <u>Shoulder widths</u> | <u>Other</u> |
| <u>(explain):</u> | () <u>Bridge widths</u> | | | |
| () <u>Lane Width</u> | <u>Structural capacity</u> | () <u>Maximum Grade</u> | <u>Vertical clearance</u> | _____ (→) |
| <u>Grades</u> | | () <u>Cross slope</u> | | |
| () <u>Shoulder Width</u> | <u>Superelevation</u> | () <u>Cross Slope</u> | <u>Horizontal alignment</u> | _____ (→) |
| <u>Vertical alignment</u> | | | | |
| () <u>Horizontal Curve Radius</u> | <u>Stopping sight distance</u> | () | | <u>Vertical</u> |
| <u>Clearance</u> | <u>Horizontal clearance</u> | <u>Lateral Offset</u> | | |
| () <u>Superelevation Rate</u> | | () <u>Design Loading</u> | <u>Structural Capacity</u> | |

Include a brief statement concerning the project and items of concern.

Attach all supporting documentation to this exhibit in accordance with Chapter 14 SECTION 14 – ED.

Recommended by: _____
(Responsible Professional Engineer)

Approval: _____
(Maintaining authority's designated Professional Engineer)

Concurrence: _____
FDOT/FHWA (if applicable)

Concurrence:- _____
FHWA (if applicable)

CHAPTER 17

BRIDGES AND OTHER STRUCTURES

1		
2		
3	<u>A</u>	<u>INTRODUCTION 17-1</u>
4	<u>B</u>	<u>OBJECTIVES 17-2</u>
5	<u>C</u>	<u>DESIGN 17-2</u>
6		<u>C.1 Bridges - General 17-2</u>
7		<u>C.2 Bridge Live Loads 17-2</u>
8		<u>C.3 Bridge Superstructure 17-3</u>
9		<u>C.3.a Girder Transportation 17-3</u>
10		<u>C.3.b Vertical Clearance 17-3</u>
11		<u>C.3.c Railings 17-4</u>
12		<u>C.3.d Expansion Joints 17-4</u>
13		<u>C.3.e Drainage 17-5</u>
14		<u>C.3.f End Treatments 17-5</u>
15		<u>C.4 Bridge Substructure 17-5</u>
16		<u>C.4.a Scour 17-5</u>
17		<u>C.4.b Navigation Aids and Vessel Collision 17-6</u>
18		<u>C.4.c Pier Locations 17-717-7</u>
19		<u>C.5 Retaining and Noise Walls 17-7</u>
20		<u>C.6 Sign, Lighting, and Traffic Signal Supports 17-817-8</u>
21		<u>C.7 Pedestrian Bridges 17-8</u>
22	<u>D</u>	<u>CONSTRUCTION 17-9</u>
23	<u>E</u>	<u>ROUTINE INSPECTION AND MAINTENANCE 17-1017-10</u>
24	<u>F</u>	<u>BRIDGE LOAD RATING AND POSTING 17-1117-11</u>
25	<u>G</u>	<u>RECOMMENDATIONS 17-1317-13</u>
26	<u>H</u>	<u>REFERENCES FOR INFORMATIONAL PURPOSES 17-1417-14</u>
27	<u>A</u>	<u>INTRODUCTION 17-1</u>

1	<u>B</u>	<u>OBJECTIVES</u>	17-2
2	<u>C</u>	<u>DESIGN</u>	17-2
3		<u>C.1</u> <u>Bridges - General</u>	17-2
4		<u>C.2</u> <u>Bridge Live Loads</u>	17-2
5		<u>C.3</u> <u>Bridge Superstructure</u>	17-3
6		<u>C.3.a</u> <u>Girder Transportation</u>	17-3
7		<u>C.3.b</u> <u>Vertical Clearance</u>	17-3
8		<u>C.3.c</u> <u>Railings</u>	17-4
9		<u>C.3.d</u> <u>Expansion Joints</u>	17-5
10		<u>C.3.e</u> <u>Drainage</u>	17-5
11		<u>C.3.f</u> <u>End Treatments</u>	17-5
12		<u>C.4</u> <u>Bridge Substructure</u>	17-5
13		<u>C.4.a</u> <u>Scour</u>	17-6
14		<u>C.4.b</u> <u>Vessel Impact</u>	17-6
15		<u>C.4.c</u> <u>Pier Locations</u>	17-7
16		<u>C.5</u> <u>Retaining and Noise Walls</u>	17-7
17		<u>C.6</u> <u>Sign, Lighting, and Traffic Signal Supports</u>	17-8
18		<u>C.7</u> <u>Pedestrian Bridges</u>	17-8
19	<u>D</u>	<u>CONSTRUCTION</u>	17-8
20	<u>E</u>	<u>ROUTINE INSPECTION AND MAINTENANCE</u>	17-9
21	<u>F</u>	<u>BRIDGE LOAD RATING AND POSTING</u>	17-10
22	<u>G</u>	<u>RECOMMENDATIONS</u>	17-12
23	<u>H</u>	<u>REFERENCES FOR INFORMATIONAL PURPOSES</u>	17-13

24
25

EXHIBITS

27	EXHIBIT A	Bridge Load Rating Summary Table	17-12 17-12 17-11
28			

CHAPTER 17

BRIDGES AND OTHER STRUCTURES

A INTRODUCTION

Bridges provide safe passage for multimodal traffic over various obstacles along a road or path. This chapter presents guidelines and standards for designing, constructing, inspecting, and maintaining bridges as well as other structures such as walls and supports for signs, lights, and traffic signals. These standards and criteria are necessary due to the critical function these structures serve to communities throughout their lifespan. This chapter establishes uniform minimum standards and criteria for all bridges used by the public for vehicular and/or pedestrian traffic as well as other structures such as walls and supports for signs, lights, and traffic signals. The geometry of structures shall follow the standards and criteria set forth in **Chapters 3, 8, 9, and 13**. Exceptions to these standards and criteria must be processed in accordance with the procedures described in **Chapter 14**.

In addition to the design criteria provided in this chapter, the [2006 Americans with Disabilities Act Standards for Transportation Facilities](#) as required by [49 C.F.R 37.41 or 37.43](#) and the [2012 Florida Accessibility Code for Building Construction](#) as required by 61G20-4.002 impose additional requirements for the design and construction of pedestrian facilities on bridges or other structures. Examples of facilities include sidewalks and shared use paths, and drainage grates and inlets in or near the accessible route. Significant ADA design considerations exist for all facilities with grades that exceed 5%.

Note: This chapter applies to all bridges under local control, with the exception of bridges constructed on or over the Department's system. For bridges constructed on and over the Department's system, as well as all bridges that will be maintained by the Department, the Department's policies, procedures, standards and specifications will apply.

B OBJECTIVES

The objectives [HMJ1] of this chapter are as follows:

- To prescribe uniform criteria with respect to bridge and miscellaneous structures design and geometric layout.
- To alert owners to the various federal and state requirements to be included in the design, construction, maintenance, and inspection of their bridges and other structures.
- To provide practical suggestions specific to Florida on prudent structural engineering based on past experience with statutes, standards, and criteria.

C DESIGN

The design of bridges and other structures shall be led by a licensed professional engineer who shall assume responsible charge of the work. The standards and criteria included here are directed only toward specific considerations that shall be followed. Other considerations are necessary to create a comprehensive bridge design allowing owners and their engineer's flexibility in design. All bridges and other structures shall be designed in accordance with specifications (including guide specifications) published by the American Association of State Highway and Transportation Officials (AASHTO).

C.1 Bridges - General

At a minimum, the [AASHTO Load and Resistance Factor Design \(LRFD\) Bridge Design Specifications, 7th Edition \(2014\) with Interim Revisions \(2015 and 2016\)](#) [KM2] shall be used. Any bridge reconstruction (i.e., lengthening, and/or major component replacement) shall be designed as specified in this section. Record of such reconstruction shall be maintained as specified in Section D of this chapter. The remaining design life should be considered in the design.

C.2 Bridge Live Loads

In addition to the notional (HL - 93) design load specified in *LRFD*, bridges shall also require a FL 120 permit load rating greater than 1 as defined in the [FDOT Structures Manual, Volume 1 – Structures Design Guidelines, 2017 \(SDG\)](#). This vehicle allows for a more consistent load rating comparison considering the current bridge inventory.

C.3 Bridge Superstructure

The superstructure of a bridge is that portion of the structure that spans between its supports or piers. Considerations that shall be incorporated into the design of all superstructures will include the following:

C.3.a Girder Transportation

The Engineer of Record (EOR) is responsible for investigating the feasibility of transportation for heavy, long and/or deep girder field sections. In general, the EOR should consider the following during the design phase:

- Whether or not multiple routes exist between the bridge site and a major transportation facility.
- The transportation of field sections longer than 130 ft or weighing more than 160,000 pounds requires coordination through the Department's Permit Office during the design phase of the project. Shorter and/or lighter field sections may be required if access to the bridge site is limited by roadway(s) with sharp horizontal curvature or weight restrictions.
- On steel superstructures, where field splice locations required by design result in lengths greater than 130 feet, design and detail "Optional Field Splices" in the plans.
- For curved steel box girders, prefabricated trusses, and integral pier cap elements, size field pieces such that the total hauling width does not exceed 16 feet.

C.3.b Vertical Clearance

All new bridges over roadways and shared use paths shall be designed to meet the vertical clearance standards specified in **Chapter 3, Section C.7.j.4.(b)**, and **Chapter 9, Section C.6**.

All new bridges over water shall be designed to meet the following vertical clearance standards:

- To allow debris to pass without causing damage, the clearance between the design flood stage and the low member of bridges shall be a minimum of two feet. This standard does not apply to culverts and bridge-culverts.

- For crossings subject to boat traffic, the minimum vertical navigation clearance should be:

Tidewater bays and streams	6 feet above Mean High Water *
Freshwater rivers, streams, non-regulated/controlled canals, and lakes	6 feet above Normal High Water
Regulated/controlled lakes and canals	6 feet above control elevation

- * For locations subject to tidal salt / brackish water splashing, a 12 foot vertical clearance above Mean High Water should be considered for bridge durability reasons.

Higher clearances apply for crossings over legislated channels under the control of the U.S. Coast Guard (USCG). Designers should also consider future navigation demands and future shared use path demands in setting the vertical clearance of a bridge.

C.3.c Railings

All traffic, pedestrian, and bicycle railings shall comply with the requirements in **Section 13** of *LRFD*. Traffic railings shall meet the crash requirements of at least Test Level 3 (TL-3) for bridges with design speeds greater than 45 mph and at least TL-2 for design speeds less than or equal to 45 mph.

For pedestrian/bicycle railings, two-pipe guiderails and details similar to the Department's [Design Standards, Indexes 870 or 880](#) may be mounted on walls or other structures where drop-off hazards are 5 feet or less. Concrete, aluminum or steel railing and details similar in strength and geometry to the Department's [Design Standards, Indexes 820 thru 862](#) shall be used (or modified to suit environmental runoff concerns) where drop-off hazards are greater than 5 feet. See appropriate Instructions for [Design Standards \(IDS\)](#) for more information.

C.3.d Expansion Joints

The number of joints should be minimized to reduce the inspection and maintenance needs of the bridge.

C.3.e Drainage

All bridge designs shall include a drainage design that is specific to its site. Conveyance of drainage off the bridge roadway should be designed to meet spread standards contained in the most recent version of the Department's [Drainage Manual, Chapter 3](#) and may include open systems (i.e., scuppers) or closed systems (i.e., inlets and pipes) based on environmental permitting restrictions. Drainage from the bridge should not drop onto traffic below. Longitudinal conveyance piping attached to bridges is expensive and maintenance-intensive, and should be avoided whenever possible.

Conveyance of drainage off pedestrian facilities shall be designed to provide an accessible route for pedestrians. Further guidance on the design of bridge deck drainage may be found in the current version of [FHWA Publication HEC-21, "Design of Bridge Deck Drainage."](#)

C.3.f End Treatments

Requirements for end treatments of structures are given in **Chapter 4 – Roadside Design**. Bridge barriers shall be designed to accommodate connection of a guardrail transition or energy absorbing system.

C.4 Bridge Substructure

The substructure of a bridge consists of all elements below the superstructure including its bearings, piers, and foundations. For guidance on bridges vulnerable to coastal storms, see [SDG, Section 2.5](#). Considerations that shall be incorporated into the design of all substructures include the following:

C.4.a Scour

A hydrologic/hydraulic analysis shall be performed to quantify expected stages and flows at the bridge site. Anticipated substructure scour shall be developed for the following conditions:

Hydraulic Design Flood Frequency	Scour Design Flood Frequency	Scour Design Check Flood Frequency
Q ₁₀	Q ₂₅	Q ₅₀
Q ₂₅	Q ₅₀	Q ₁₀₀
Q ₅₀	Q ₁₀₀	Q ₅₀₀
Notes: "Q" is the common term used for flow rate, an expression of volume of fluid which passes per unit of time. "x" is the return period in years (10, 25, 50, 100, 500).		

Any exceptions to the standards above hydrologic/hydraulic and scour analysis requirements shall be approved in writing by the Department's local District Drainage Engineer. Methodology for computing bridge hydrology/hydraulics and bridge scour should follow the guidelines set forth in the most recent version of the Department's [Drainage Manual](#), incorporated by [Rule 14-86.003, F.A.C.](#) Further guidance and training may be obtained through [FHWA Hydraulic Engineering Circulars \(HEC\) "HEC-18"](#) and ["HEC-20"](#) and the Department's training courses on these topics. Additionally, for larger bridges (>120,000 sq. ft.), hydraulic designers may wish to consult with the local Department District Drainage Engineer for case-specific guidance. The [SDG, Section 2.11](#) and [2.12](#) and the Department's [Drainage Manual, Chapter 4](#) provide guidance on scour load combinations with other loads.

C.4.b [Navigation Aids and Vessel Collision](#) Impact

All bridges over USCG designated navigable waterways shall include [bridge fender systems and](#) consideration for potential vessel collision. ~~Such collisions generally occur from barges or oceangoing ships. The engineer shall conduct a vessel risk analysis to determine the most economical method for protecting the bridge. This shall include either designing the bridge to withstand the vessel collision, or protecting it with dolphin cells. Fender systems should only be used to designate the channel width and not for pier protection. The above risk analysis may be conducted utilizing the Department's computer program "Vessel Impact Risk Analysis." For load combinations, use Load Combination "Extreme Event II" as follows:~~

$$\text{(Permanent Dead Loads)} + \text{WA} + \text{FR} + \text{CV}$$

~~With all load factors equal to 1.0 where WA are water loads, FR are friction~~

~~forces and CV are the vessel collision loads. Nonlinear structural effects must be included and can be significant. It is anticipated that the entire substructure (including piles) may have to be replaced and the superstructure repaired if a bridge is subjected to this design impact load; however, the superstructure must not collapse.~~

~~Note: Further refinement or complication of this load case is unwarranted.~~

~~For Further~~ guidance on navigation aids and bridge fender system design, see SDG Section 314. For guidance on vessel collision design see ~~may be obtained from the~~ **SDG, Section 2.11** and **LRFD, Section 3.14**.

~~For guidance on bridge fender system design, see and FDOT Design Standard Indexes 21900 and 21930.~~

C.4.c Pier Locations

All bridges over roadways shall have substructures supports set back from vehicular traffic lanes in accordance with **Chapter 3, Section C.7.j.4.(a)**.

All bridges over water shall have substructure supports located with horizontal clearance requirements as listed below. In this case, horizontal clearance is defined as the clear distance between piers, fender systems, culvert walls, etc., projected by the bridge normal to the flow.

- For crossings subject to boat traffic a minimum horizontal clearance of 10 feet shall be provided.
- Where no boat traffic is anticipated, horizontal clearance shall be provided consistent with debris conveyance needs and structure economy.

C.5 Retaining and Noise Walls

The design of conventional, anchored, mechanically stabilized, and prefabricated modular retaining wall structures shall meet the requirements of **LRFD Section 11**. Local agencies should consider using only wall types approved by the Department. These are described in **Section 3.12** of the **SDG**. Local agencies should also follow the design criteria for retaining walls found in **Section 3.13** of the **SDG**.

The design of noise walls **should** **meet**^[KM3] the requirements of the **SDG, Section 3.16**. For noise walls within the clear zone, their design and/or protection **should** all comply with the following:

- For noise walls attached to the top of traffic railings only use crash tested systems consistent with the design speed of the facility. The Department has standards for TL-4 systems that meet the requirements of [NCHRP Report 350 or the Manual for Assessing Safety Hardware \(MASH\)](#).
- Non-crash tested noise walls may be attached to structures if located behind an approved traffic railing and mounted at least five feet from the face of the traffic railing at deck level.

Potential existing off-site stormwater inflows through the proposed wall location should be verified in the field and considered in the wall design. For railings on top of walls, see **Section C.3.c. Railings**.

C.6 Sign, Lighting, and Traffic Signal Supports

The design of sign, lighting, and traffic signal support structures shall meet the requirements of [AASHTO's LRFD Specifications for Structural Supports for Highway Signs, Luminaires and Traffic Signals, 1st Edition \(2015\) with 2017 Interims](#), and the Department's [Structures Manual Volume 3 - FDOT Modifications to LRFD Specifications for Structural Supports for Highway Signs, Luminaires and Traffic Signals \(LRFDLTS-1\)](#).

C.7 Pedestrian Bridges

For guidance on pedestrian bridges, see [SDG Chapter 10](#).

D CONSTRUCTION

During the construction of a bridge or any structure at, over, or near a public facility, safety awareness is necessary and precautions shall be taken to protect the public. Provisions for protecting the public during construction shall be in accordance with the [MUTCD](#) work zone traffic control procedures and the standards and criteria described in **Chapter 11 – Work Zone Safety**. Worker safety is the responsibility of the contractor. Temporary barriers shall be installed on all bridges being widened or whose new construction is phased. Spread of stormwater on the bridge deck should be considered in planning temporary traffic routing.

During the construction of a bridge or any structure, records to be kept and maintained throughout its life shall include foundation construction records (pile driving records, shaft tip elevations, borings) and as-built plans. These records provide critical information necessary for future inspection, maintenance, emergency management, enhancement, reconstruction, and/or demolition of these structures. These records shall be delivered to the Department's local District Structures Maintenance Engineers.

Any proposed changes to the construction details or specifications shall be signed, sealed, and dated by a professional engineer licensed in the State of Florida.

E ROUTINE INSPECTION AND MAINTENANCE

[Title 23, Code of Federal Regulations, Part 650, Subpart C](#), sets forth the **National Bridge Inspection Standards (NBIS)** for bridges on all public roads. **Section 650.3** defines bridges, specifies inspection procedures and frequencies, and indicates minimum qualifications for personnel. Each state is permitted to modify its bridge inspection standards to deviate from the NBIS standards but only following approval from the FHWA.

[Section 335.074, F.S.](#), mandates safety inspection of bridges ~~as follows:~~

~~“At regular intervals not to exceed 2 years, each bridge on a public transportation facility shall be inspected for structural soundness and safety for the passage of traffic on such bridge. The thoroughness with which bridges are to be inspected shall depend on such factors as age, traffic characteristics, state of maintenance, and known deficiencies. The governmental entity having maintenance responsibility for any such bridge shall be responsible for having inspections performed and reports prepared in accordance with the provisions contained herein.”~~

~~This statute also defines the minimum dimensions of bridge structures that must be inspected as follows:~~

~~“Those bridges having an opening measured along the center of the roadway of more than 20 feet between undercopings of abutments or spring lines of arches or extreme ends of openings for multiple boxes and those bridges consisting of multiple pipes where the clear distance between openings is less than half of the smaller contiguous opening[[KM4](#)].”~~

~~Bridge inspectors shall be certified in accordance with [Chapter 14-48, F.A.C.](#) Safety inspection of bridges shall be conducted in accordance with [Chapter 14-48, F.A.C.](#)~~

The Department inspects all bridges in Florida, both on-system and off-system. The Department provides each local government with copies of its inspection reports. Each local government should maintain these reports to be responsive to Metropolitan Planning Organization requests for bridge rehabilitation, replacement, or enhancement designations.

All on-system and off-system bridges are assigned a Bridge Number by the Department. For new bridges, local agencies shall contact the Department’s local District Structures Maintenance Engineers to have a number assigned.

F BRIDGE LOAD RATING AND POSTING

[Section 335.074, F.S. Safety Inspection of Bridges](#) requires that bridges on a public transportation facility be inspected for structural soundness and safety at regular intervals. The inspection shall consider age, traffic characteristics, state of maintenance, and known deficiencies of the bridge. The governmental entity having maintenance responsibility for any such bridge shall be responsible for having inspections performed and reports prepared.

As required by [Section 335.074, F.S.](#), each inspection shall be reported to the Department, using the Bridge Load Rating Summary Table form shown in Exhibit A. Further information for preparing a bridge load rating summary and fillable form may be found on the Department's Office of Maintenance, Bridge Information web site at the following location:

<http://www.dot.state.fl.us/statemaintenanceoffice/LoadRating.shtm>

Upon receipt of an inspection report that recommends reducing the weight limit on a bridge, the governmental entity having maintenance responsibility for the bridge shall load post the bridge within 30 days in accordance FS 335.074(5). Further requirements for reporting and posting of weight, size or speed limits on bridges are found in this statute, [Section 316.555 F.S. Weight, load, speed limits may be lowered.](#) The appropriate signage shall be promptly installed in accordance with the MUTCD.

For new construction or reconstruction projects, the bridge owner is responsible for providing the Department with a load rating and completed Bridge Load Rating Summary Table (see Exhibit A – Bridge Load Rating Summary Table) within 90 days of opening for on-system bridges or 180 days for off-system bridges. The bridge owner should consider requiring the engineer of record to perform the load rating.

EXHIBIT A Bridge Load Rating Summary Table

Bridge No.		Analysis Method: LRFR-LRFD						FDOT Bridge Load Rating Summary Form (Page 1 of 1)			
Bridge Name											
Description											

Rating Type	Rating Type	Gross Axle Weight (tons)	Moment/Shear/Service	Dead Load Factor	Live Load Factor	Live Load Distrib. Factor (axles)	Rating Factor	Span No. - Girder No., Interior/Exterior, %Span L	Pontis RF-Weight (tons)
Level	Vehicle	Weight	Member Type Limit	DC	LL	LLDF	RF	Governing Location	RATING
Inventory	HL93	36	Member Type Limit Test	NA	NA				
Operating	HL93	36	Member Type Limit Test	NA	NA				
Permit	FL120	60	Member Type Limit Test	NA	NA				
Max Span	FL120	60	Member Type Limit Test	NA	NA				
Legal	SU2	17	Member Type Limit Test	NA	NA				
	SU3	33	Member Type Limit Test	NA	NA				
	SU4	35	Member Type Limit Test	NA	NA				
	C3	28	Member Type Limit Test	NA	NA				
	C4	36.7	Member Type Limit Test	NA	NA				
	C5	40	Member Type Limit Test	NA	NA				
	ST5	40	Member Type Limit Test	NA	NA				

Original Design Load	enter Original Design Load	Performed by:		Date:	
Rating Type, Analysis	enter Rating Type	Checked by:		Date:	
Distribution Method	enter Distribution Method	Sealed By:		Date:	
Impact Factor	enter IM (axle loading)	FL P.E. No.:			
FL120 Gov. Span Length	enter Gov Length (feet)	Cert. Auth. No.:			
Recommended Posting	enter Posting (70)	Phone & email:			
Rec. SU Posting	enter SU posting (tons)	Company:			
Rec. C Posting	enter C posting (tons)	Address:			
Rec. ST5 Posting	enter ST5 posting (tons)	<i>P.E. Seal</i>			
Floor Beam Present?	FLOOR BEAM PRESENT?				
Segmental Bridge?	SEGMENTAL BRIDGE?				
Project No. & Reason	FIN No. Update				
Status	Status				
Software Name, Version	Enter Software Name & Version				
COMMENTS BY THE ENGINEER					
Page 1/XX. Contents: summary, narrative, plans, calcs, check.					

This 04-24-2016 table is based on requirements within the 2016 FDOT Bridge Load Rating Manual, and the BMS Coding Guide; see <http://www.dot.state.fl.us/statemaintenanceoffice/LoadRating.shtm>

G RECOMMENDATIONS

- Involve the public in determining “*the appropriate aesthetics based upon scale, color, and architectural style, materials used to construct the facility, and the landscape design and landscape materials around the facility...*” (Section 336.045, F.S.).
- Resist the temptation to enhance the aesthetics of a bridge with non-structural appurtenances and features that are novel and therefore may have safety challenges (otherwise, consult with the Department on these safety issues).
- Consider the potential for future expansion of a bridge’s capacity (vehicular transit and pedestrian) in its layout and bridge-type selection.
- Use the Department’s objective construction unit prices (contained in the Structures Design Guidelines, Sections 9.2 and 9.3) to select bridge type(s) to consider for final design.
- Consider the use of alternative designs (i.e., steel superstructures vs. concrete superstructures) to increase bidding competition on very large bridge construction projects.
- ~~Consider factors other than economics in decisions on a bridge’s basic design and its discretionary features.~~
- Invest in a comprehensive subsurface investigation of the site before any significant design of the bridge occurs (which will also help avoid unforeseen conditions during construction).
- Consult with other local officials on experiences relating to construction of other bridges in the area.
- Consider using the Department’s Standard Specifications for Road and Bridge Construction with notes on the plans referencing the Owner as the local governmental agency and the Engineer as the owner’s engineer.
- Consider the constructability, inspectability, and maintainability of all bridge components before they are incorporated into the project’s final design.
- Include drainage pass-throughs in wall designs.
- ~~Preclude contractors without company or individual bridge experience from bidding on a bridge construction project.~~
- Provide qualified construction inspection personnel for all phases of bridge construction.
- Maintain all design and construction records in a safe, protected, and secure location throughout the life of the bridge.

H REFERENCES FOR INFORMATIONAL PURPOSES

The publications referenced in this chapter can be obtained from the following websites.

- FDOT Structures Design Guidelines (SDG)
<http://www.fdot.gov/structures/>
- FDOT Bridge Load Rating Manual
<http://www.fdot.gov/maintenance/LoadRating.shtm>
- All other FDOT Publications may be found at:
<http://www.fdot.gov/publications/>
- AASHTO, all publications may be ordered from:
bookstore.transportation.org
- FHWA “HEC-18” and “HEC-20” may be found at:
http://www.fhwa.dot.gov/engineering/hydraulics/library_listing.cfm
- 2006 Americans with Disabilities Act Standards for Transportation Facilities
<http://www.access-board.gov/guidelines-and-standards/transportation/facilities/ada-standards-for-transportation-facilities>
- 2012 Florida Accessibility Code for Building Construction
<https://www.flrules.org/gateway/ruleno.asp?id=61G20-4.002>