

PLAN HEADWALL AND WINGWALL ALIGNMENT

NOTE: Designs for box culverts under this Index are to be produced only by computer analysis, utilizing the program named PSTDN55. Designs under this Index are to be limited to the live loads and dimensional restraints shown in the General Notes of this Index and to the fill on the barrel(s) as shown in the roadway plans. It is the construction Contractors responsibility to provide for supporting construction loads that exceed the above loadings.

F Within these limits the top surface of the wingwalls shall be level.
 FF Within these limits the top surface of the wingwalls shall be sloped.

Headwall Valid Angles
NOTE: Headwalls with skew angles between 51° and 129° require special design authorization. Other design options should be considered. Contact the District Drainage Engineer to obtain authorization.

NOTE: All headwall and wingwall skew angles are clockwise from the direction of stationing, measured in degrees from a line perpendicular to the centerline of the culvert.

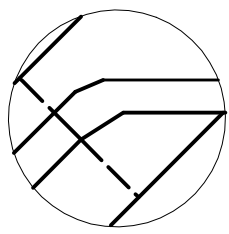

DETAIL "G"

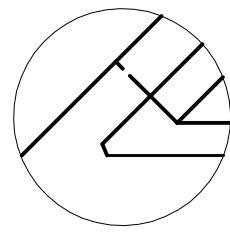

DETAIL "H"

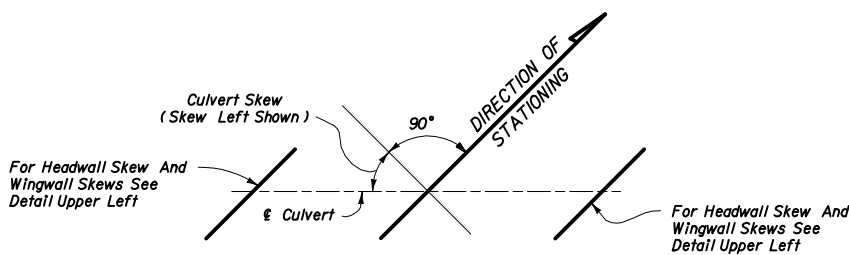

SKETCH "A" CULVERT ALIGNMENT
NOTE: For Culvert Skew See Roadway Plans.

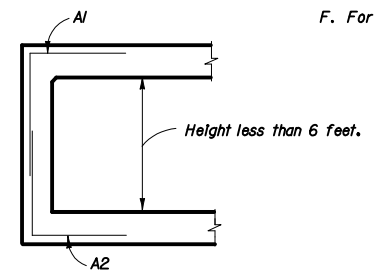

DETAIL "J"

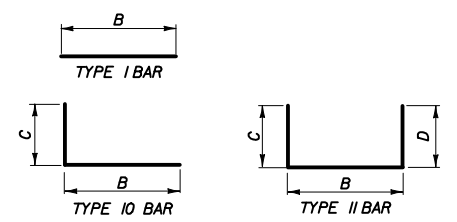
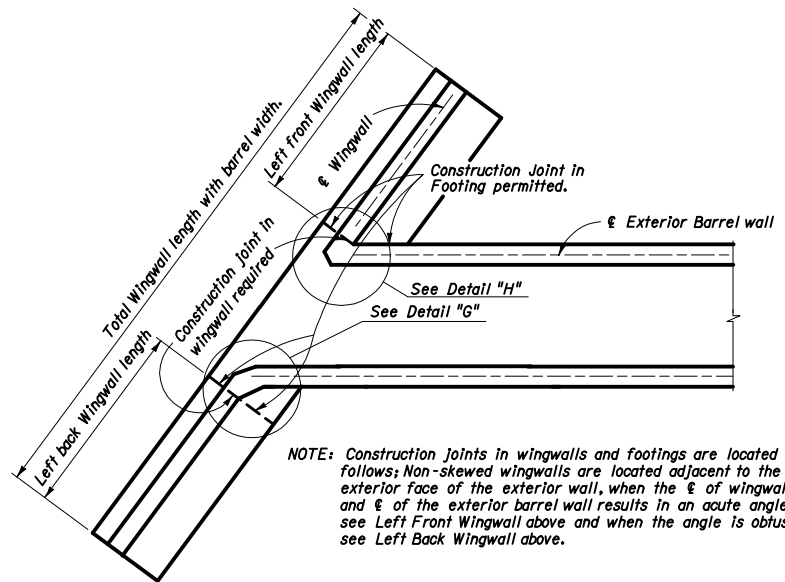

TABLE OF MINIMUM BAR SPLICE LENGTHS

| BAR SIZE | SPLICE | BAR SIZE | SPLICE |
|----------|--------|----------|--------|
| #4 | 1'-10" | #8 | 4'-8" |
| #5 | 2'-4" | #9 | 5'-3" |
| #6 | 2'-9" | #10 | 5'-10" |
| #7 | 4'-0" | #11 | 6'-6" |



PART PLAN SHOWING WINGWALLS AND THE LOCATION OF CONSTRUCTION JOINTS

NOTE: Construction joints in wingwalls and footings are located as follows: Non-skewed wingwalls are located adjacent to the exterior face of the exterior wall, when the angle of wingwall and angle of the exterior barrel wall results in an acute angle see Left Front Wingwall above and when the angle is obtuse see Left Back Wingwall above.

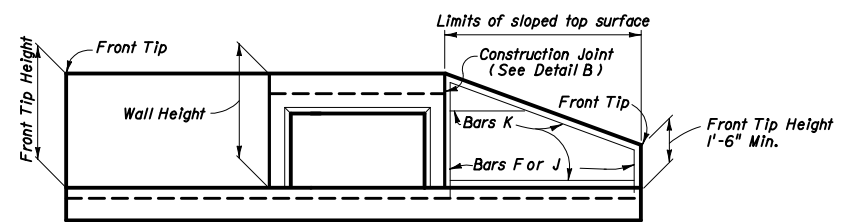

END ELEVATION OF CULVERT

NOTE: Cut the vertical bars F as required for the longest bar and use the remainder for the shortest bar in the wingwall. The vertical bars J and the horizontal bars K shall be constructed likewise. The lengths shown in the reinforcing steel bar schedule for bars F, J and K require cutting for sloped top wingwalls only.

- GENERAL NOTES**
- DESIGN SPECIFICATIONS:** A.A.S.H.T.O. 1996.
- LOADING:** HS20-44, Modified for Military Loading as Required or HS25, see Structures Design Guidelines.
- SURFACE FINISH:** The Class Surface finish for all concrete surfaces shall be a general surface finish.
- SKEWED CONSTRUCTION JOINTS:** Construction joints in barrels of culverts with skewed wingwalls may be placed parallel to the headwalls and the reinforcing steel, and the slabs may be cut provided that the cut reinforcing steel extends beyond the construction joint enough for splices to be made in accordance with the table (lower right) this sheet. The cost of construction joints shall be at the expense of the contractor.
- CULVERT EXTENTIONS:** For cut backs and ties into existing concrete box culverts see Index No. 280.
- * REINFORCING BAR SCHEDULE:**
- When the depth is less than or equal to 2', Bars C2 are utilized in the bottom of the top slab. In all other cases, Bars C2 are replaced with Bars C1 spaced at 18" on centers.
 - When the skew angle for a headwall equals 0 degrees plus or minus 12 degrees the respective S Bars (S2 or S3) will not be utilized.
 - When the barrel height is less than 6', Bars B2 will be eliminated as shown in Detail J.
 - If the span is less than 5', Bars A1 and A2 will be Type II Bars.
 - The portions of Bars "N" that extend through construction joints into wingwalls above footings shall be given one coat of approved zinc rich paint and shall be encased in approved capped plastic (PVC) pipes filled with approved durable lubricant or cut back asphalt. The length and inside diameter of the plastic pipe shall be approximately 1/4" larger than those of the bar.
 - For culvert extensions Bar C1 is redesignated Bar C3 in the bottom slab.



2006 FDOT Design Standards

CONCRETE BOX CULVERT CULVERT DETAILS

Last Revision 00 Sheet No. 1 of 5

Index No. 290

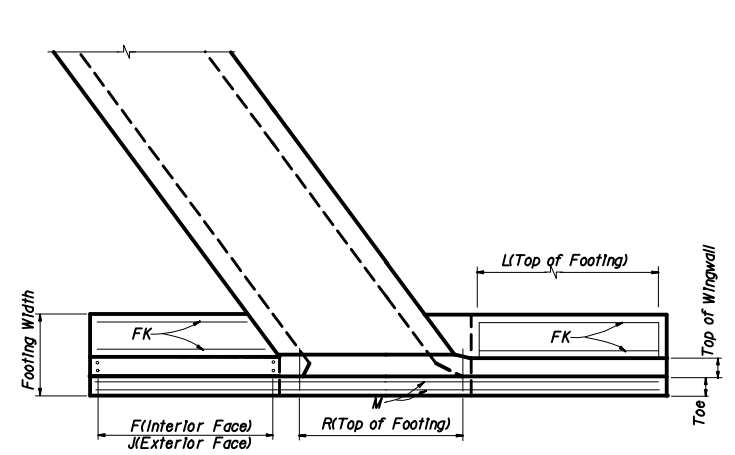

PART PLAN AT END OF CULVERT

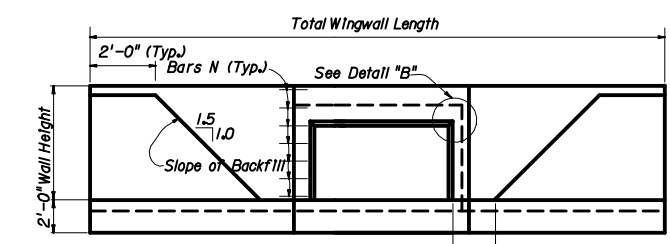

END ELEVATION

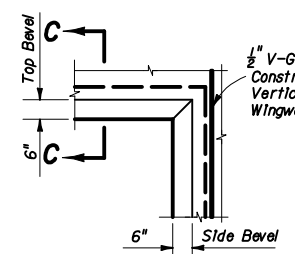

DETAIL "B"

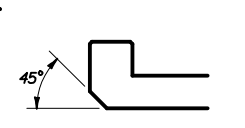

SECTION C-C

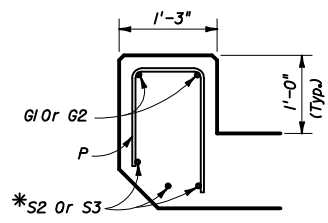

DETAIL "D"

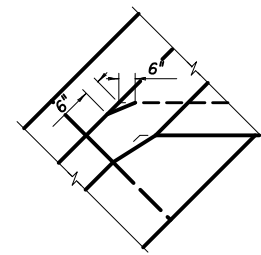

DETAIL "E"

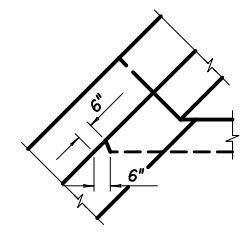

DETAIL "F"

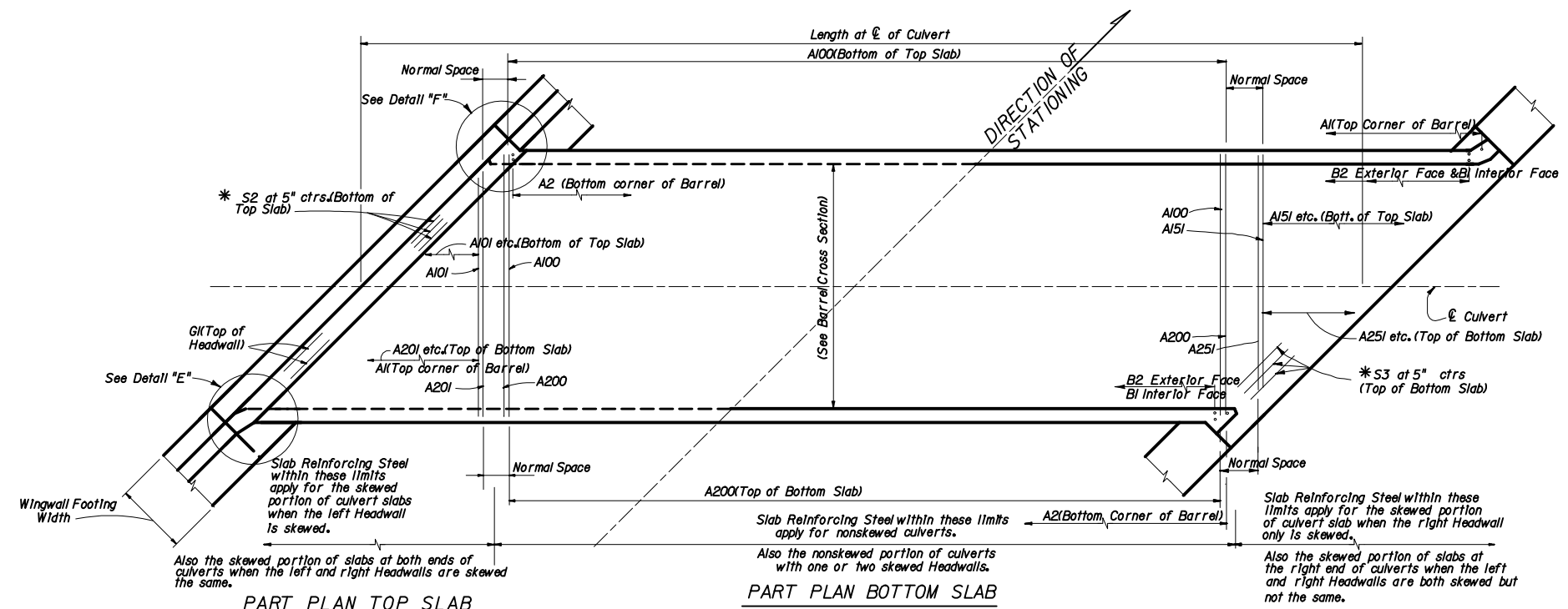

PART PLAN TOP SLAB

PART PLAN BOTTOM SLAB

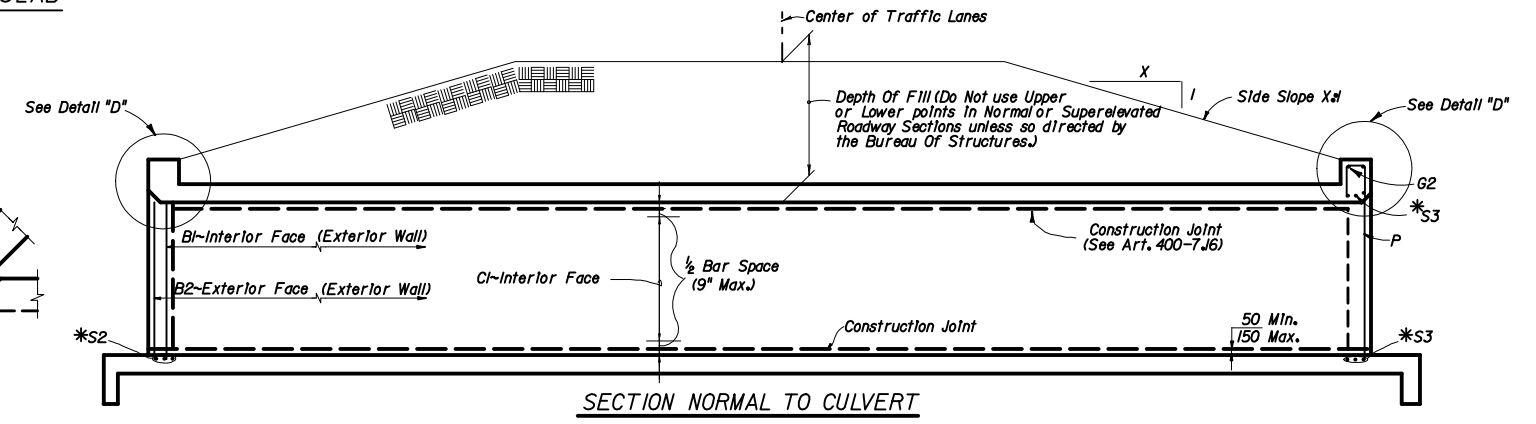

SECTION NORMAL TO CULVERT

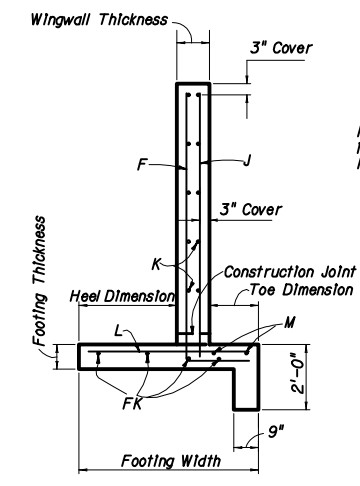

SECTION THRU WINGWALL

NOTE: For Bars F, J, K, L and or FK in the Wingwalls, the subscripts 1 thru 4 apply as follows:
 1-Left Front
 2-Left Back
 3-Right Front
 4-Right Back

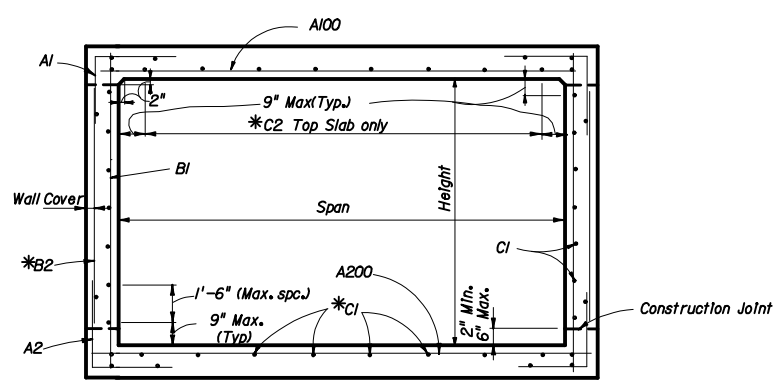

SECTION THRU BARREL

NOTE: The location of the first bar from the ends of the culvert shall not be less than 3", but not greater than one half the bar spacing.

* See Culvert Details and Reinforcing Bar Schedule, Sheet 1 of 5

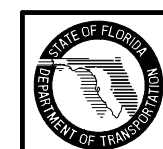

2006 FDOT Design Standards

CONCRETE BOX CULVERT
SINGLE BARREL

Last Revision 00 Sheet No. 2 of 5

Index No. 290

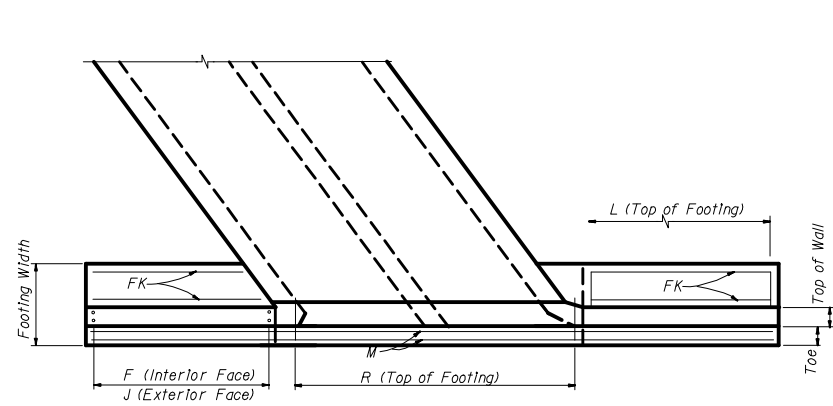

PART PLAN AT END OF CULVERT

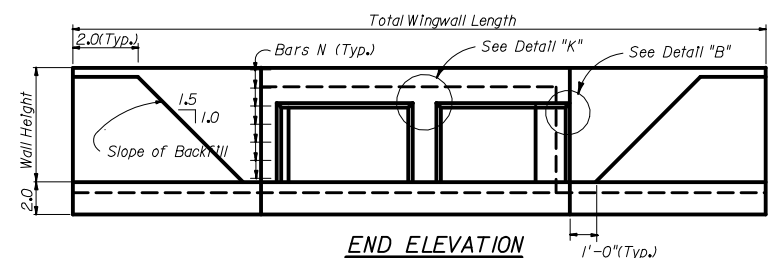

END ELEVATION

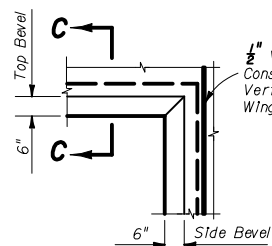

DETAIL "B"



SECTION C-C

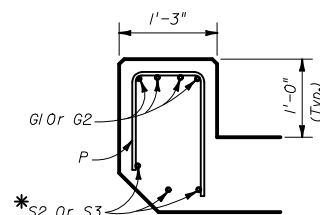

DETAIL "D"

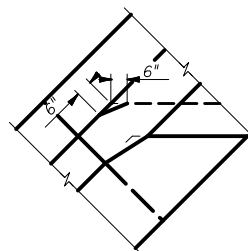

DETAIL "E"

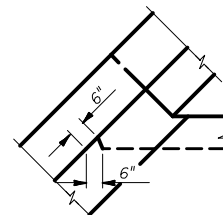

DETAIL "F"

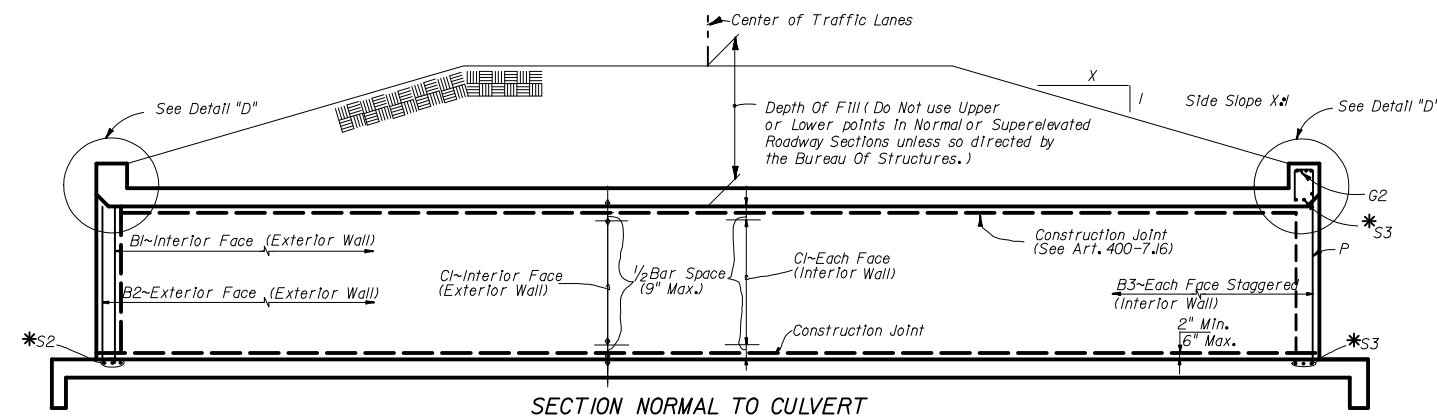

SECTION NORMAL TO CULVERT

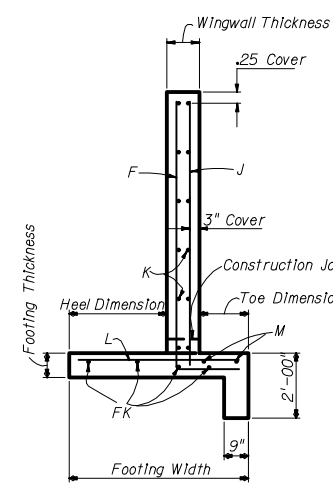

SECTION THRU WINGWALL

NOTE: For Bars F, J, K, L and/or FK in the Wingwalls, the subscripts 1 thru 4 apply as follows:
 1-Left Front
 2-Left Back
 3-Right Front
 4-Right Back

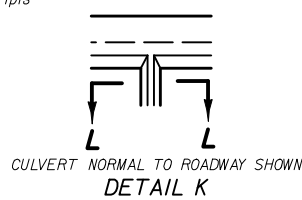

SECTION LL

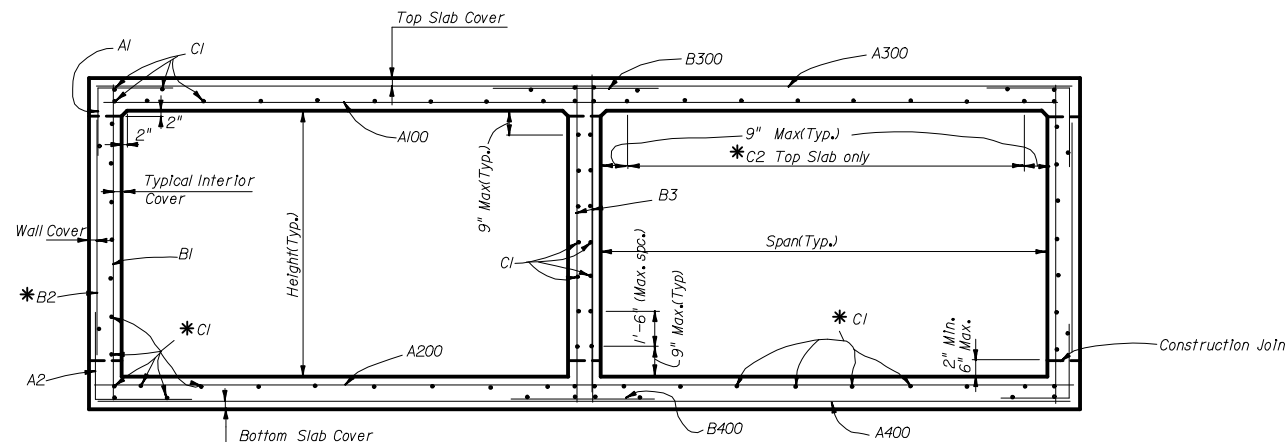

SECTION THRU BARREL

NOTE: The location of the first bar from the ends of the culvert shall not be less than 3", but not greater than one half the bar spacing.

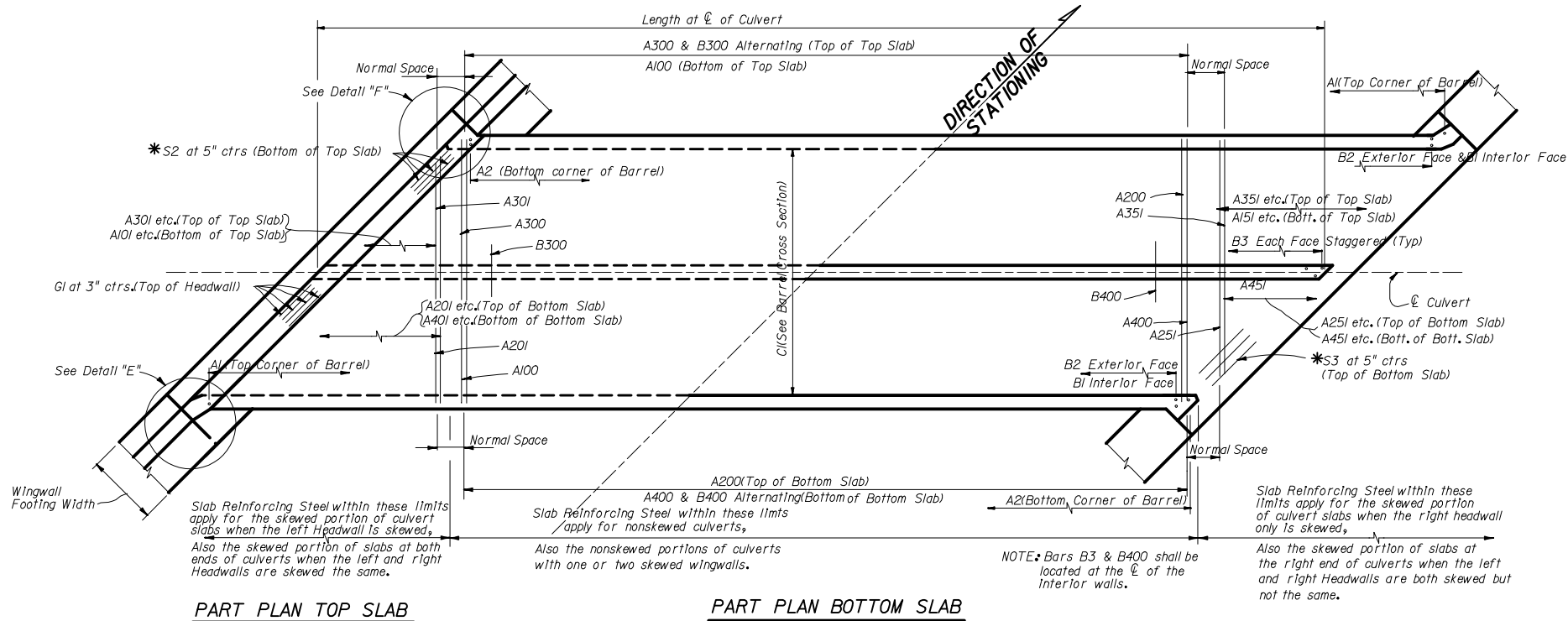

PART PLAN TOP SLAB

PART PLAN BOTTOM SLAB

* See Culvert Details and Reinforcing Bar Schedule, Sheet 1 of 5

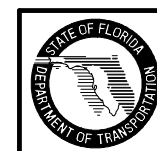

2006 FDOT Design Standards

CONCRETE BOX CULVERT
DOUBLE BARREL

Last Revision
00

Sheet No.
3 of 5

Index No.
290

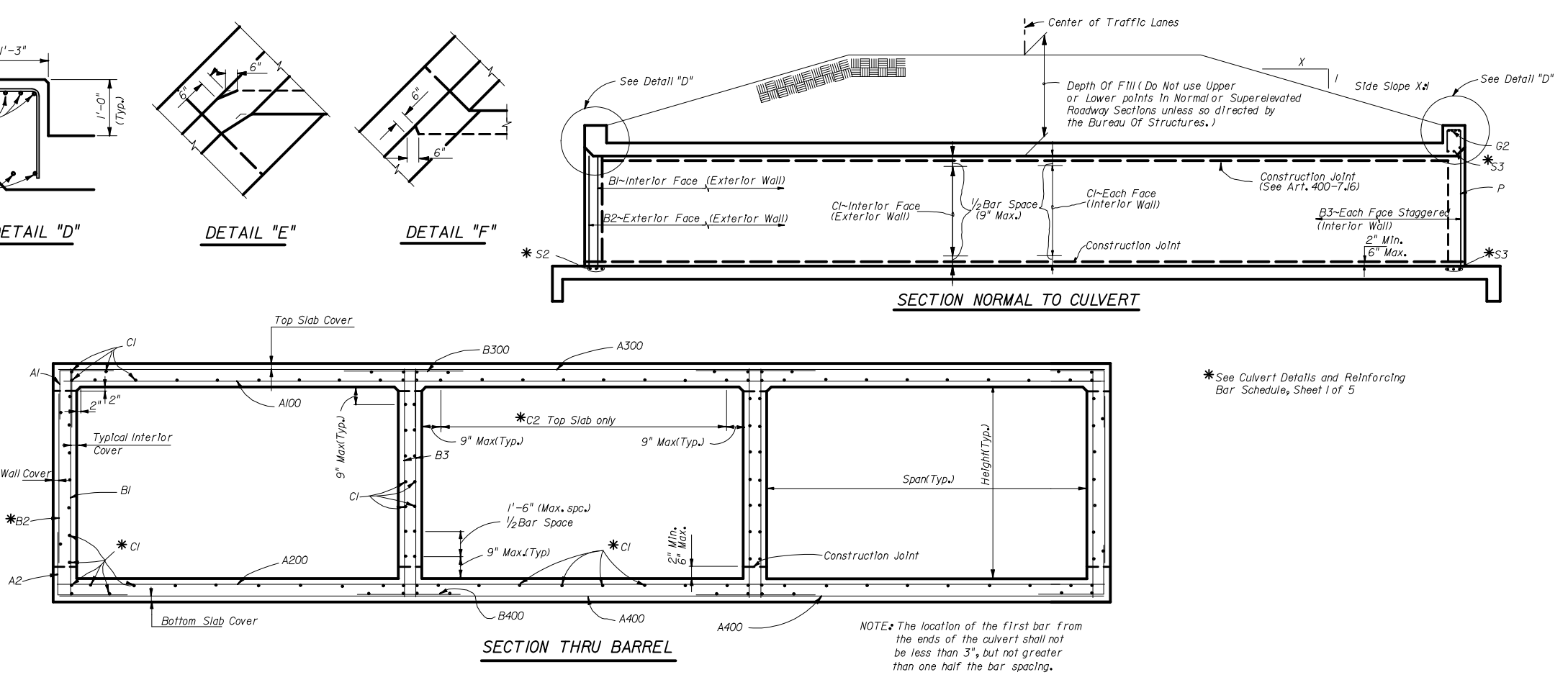
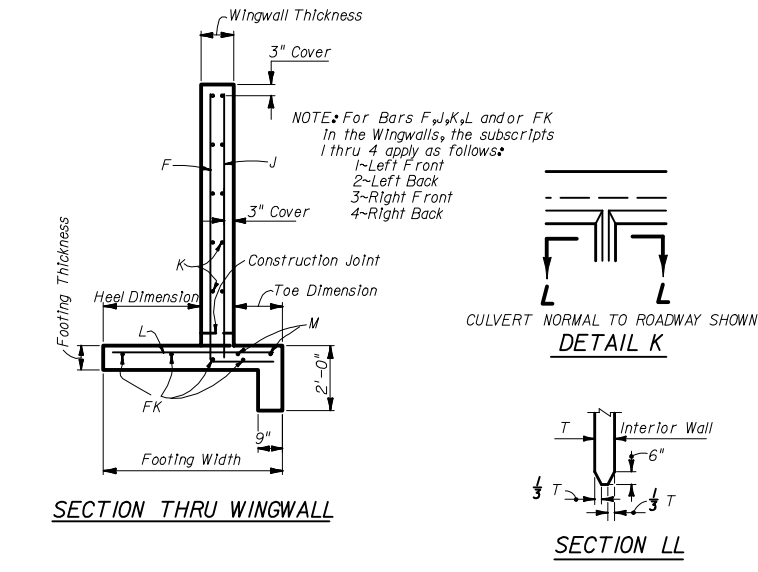
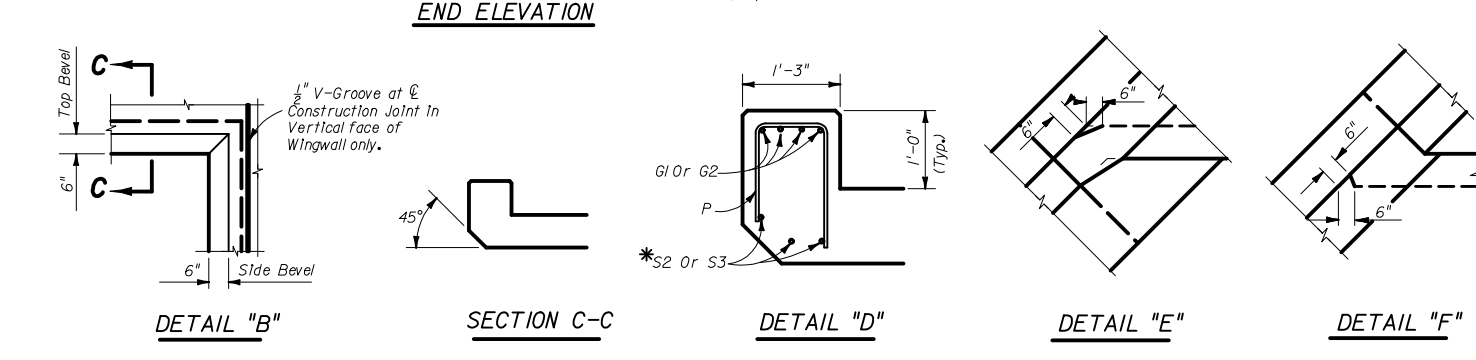
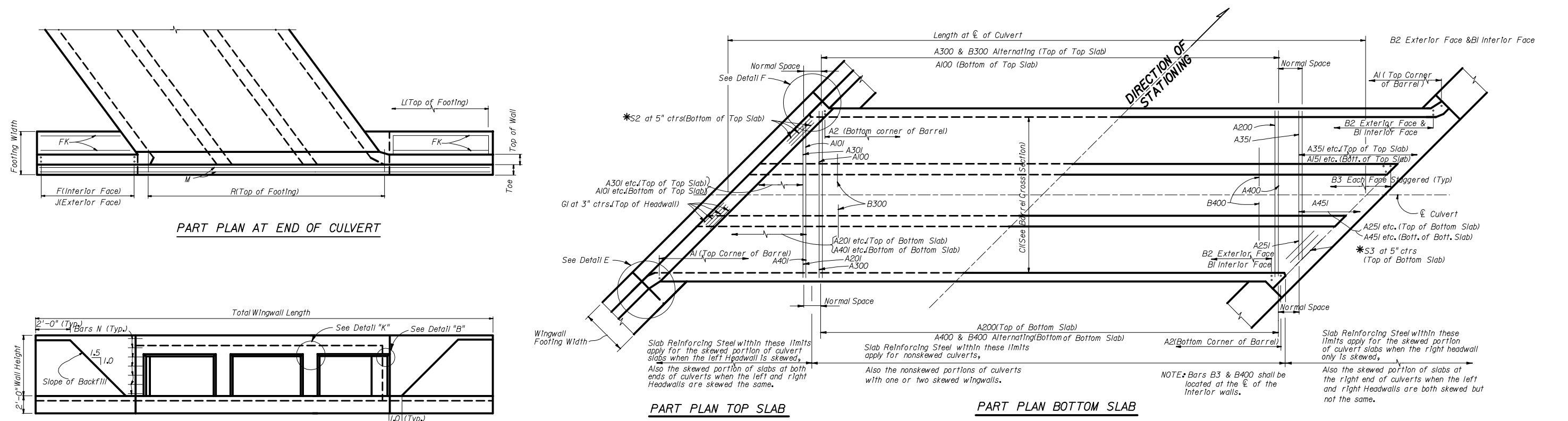

* See Culvert Details and Reinforcing Bar Schedule, Sheet 1 of 5

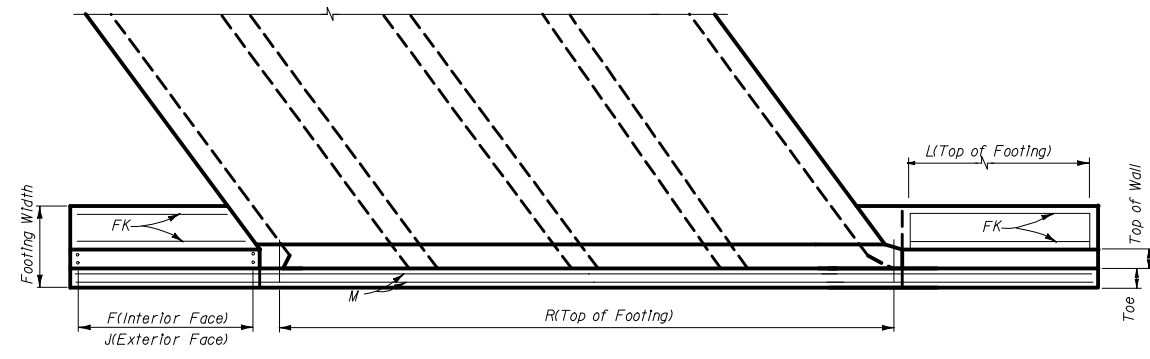

PART PLAN AT END OF CULVERT

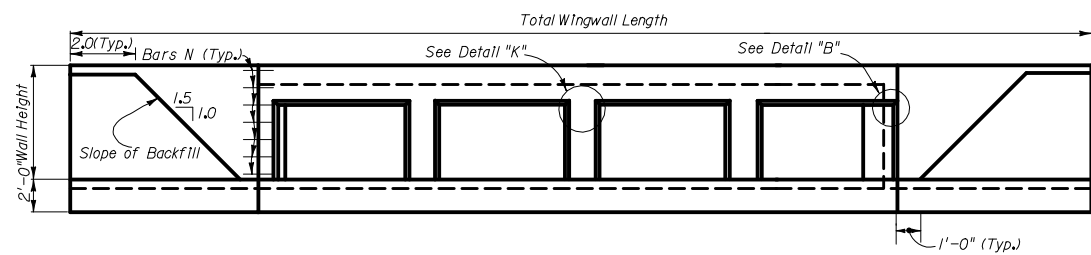

END ELEVATION

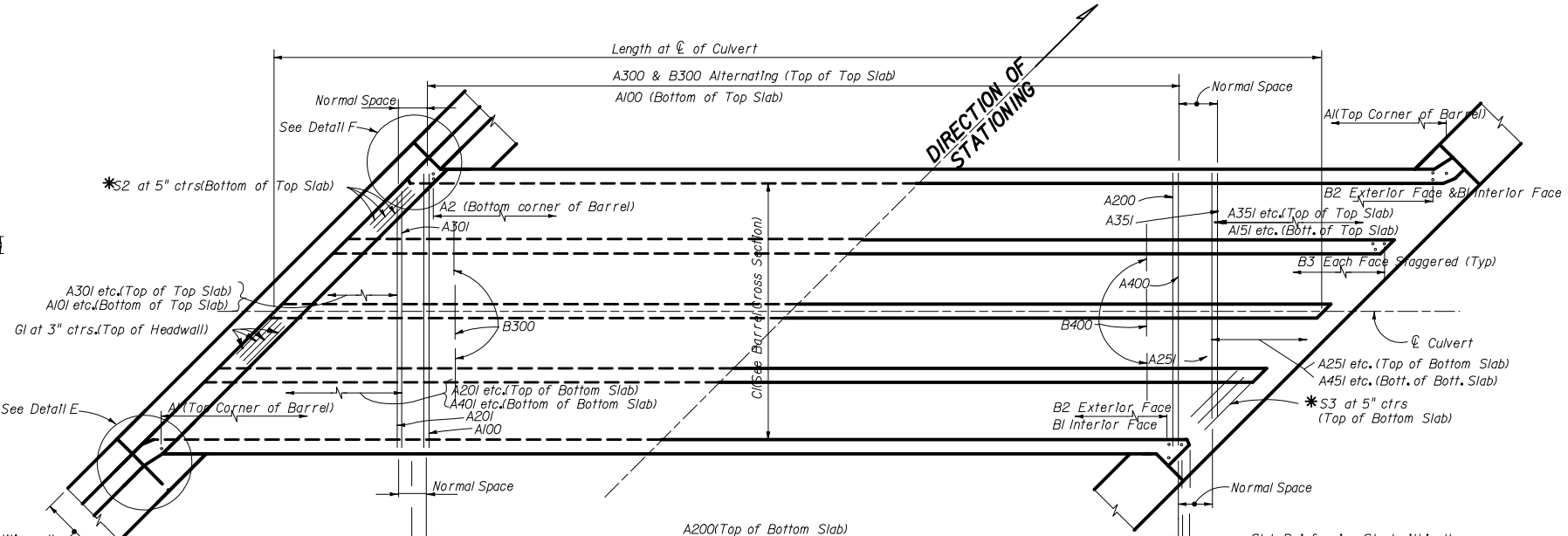

PART PLAN TOP SLAB

PART PLAN BOTTOM SLAB

Slab Reinforcing Steel within these limits apply for the skewed portion of culvert slabs when the left Headwall is skewed. Also the skewed portion of slabs at both ends of culverts when the left and right Headwalls are skewed the same.

Slab Reinforcing Steel within these limits apply for non-skewed culverts. Also the non-skewed portions of culverts with one or two skewed Headwalls.

NOTE: Bars B300 & B400 shall be located at the ϵ of the interior walls.

Slab Reinforcing Steel within these limits apply for the skewed portion of culvert slabs when the right headwall only is skewed. Also the skewed portion of slabs at the right end of culverts when the left and right Headwalls are both skewed but not the same.

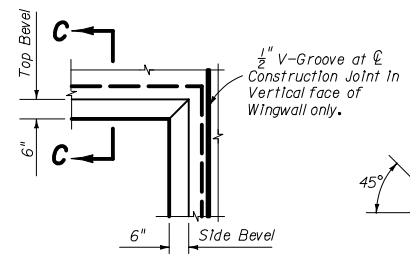

DETAIL "B"



SECTION C-C

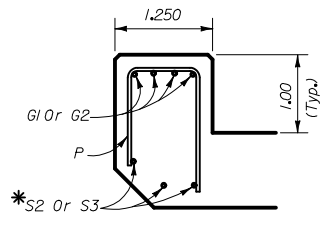

DETAIL "D"

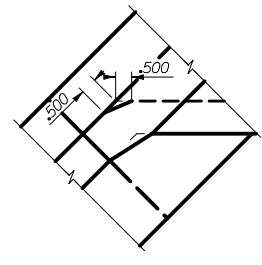

DETAIL "E"

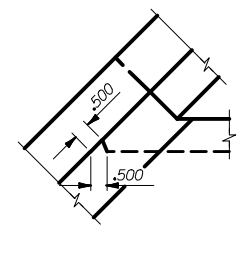

DETAIL "F"

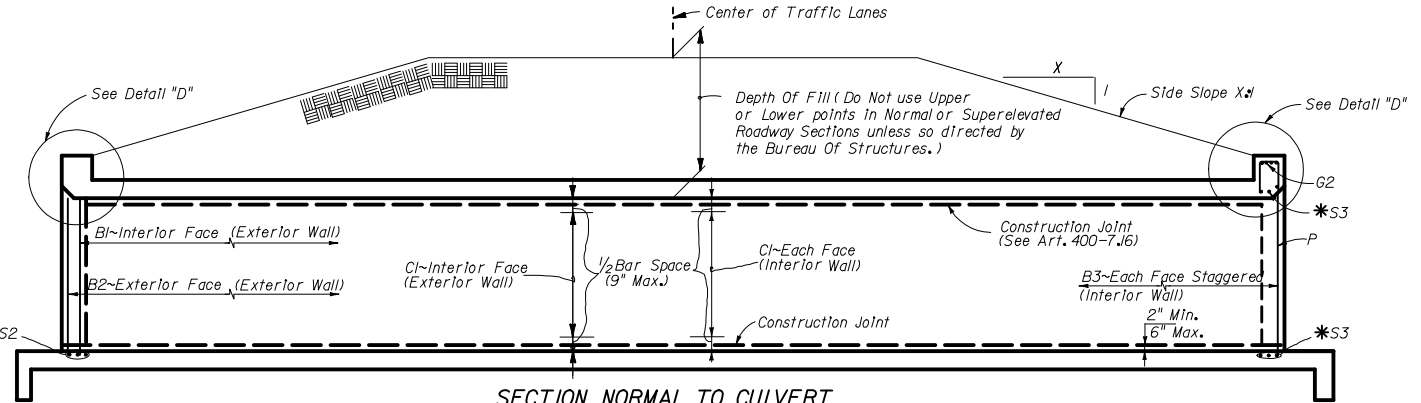

SECTION NORMAL TO CULVERT

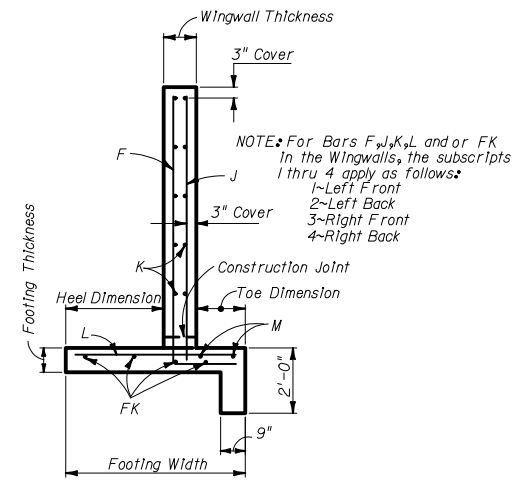

SECTION THRU WINGWALL

NOTE: For Bars F, J, K, L, and or FK in the Wingwalls, the subscripts 1 thru 4 apply as follows:
 1-Left Front
 2-Left Back
 3-Right Front
 4-Right Back

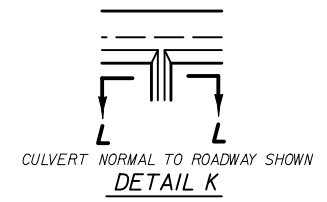

DETAIL K

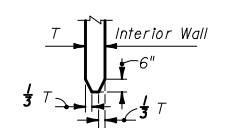

SECTION LL

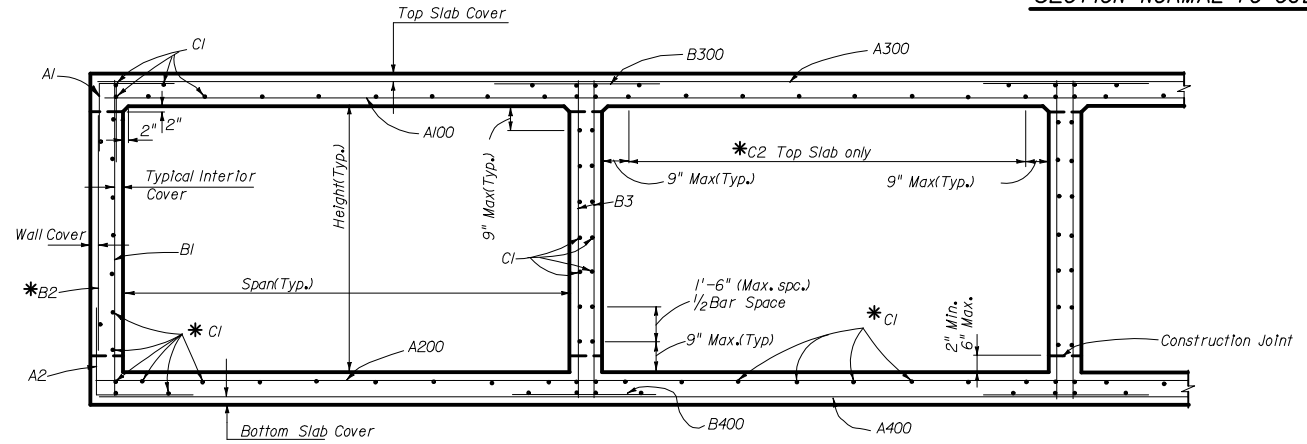

SECTION THRU BARREL

NOTE: The location of the first bar from the ends of the culvert shall not be less than 3", but not greater than one half the bar spacing.

* See Culvert Details and Reinforcing Bar Schedule, Sheet 1 of 5



2006 FDOT Design Standards

**CONCRETE BOX CULVERT
 QUADRUPLE BARREL**

| | |
|-------------------------|---------------------|
| Last Revision 00 | Sheet No. 5 of 5 |
| Index No. 290 | |