

Wrong-Way Arrow
24 S.F.

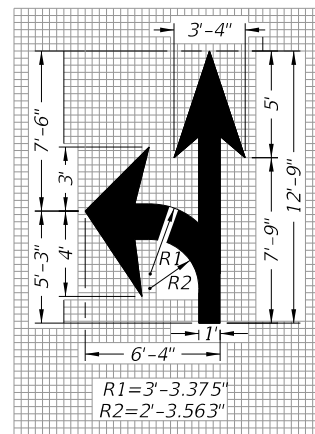

Turn and Through
Lane-Use
Arrow
29 S.F.

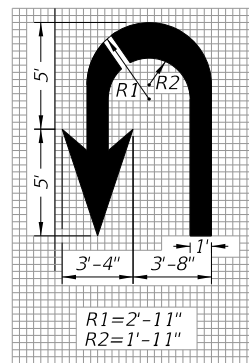

U Turn
Lane-Use
Arrow
27 S.F.

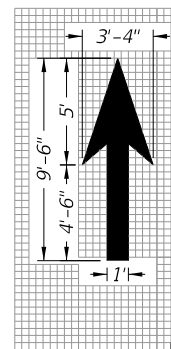

Through Lane-Use
Arrow
12 S.F.

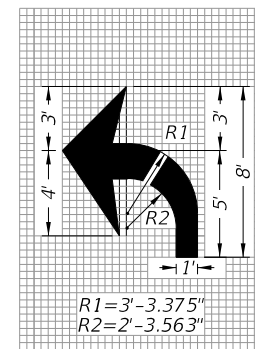

Turn Lane-Use Arrow
(Left Turn Shown -
Right Turn Similar
by Opposite Hand)
17 S.F.

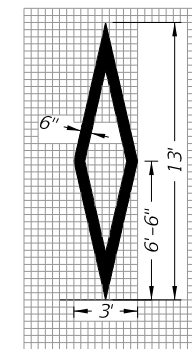

Preferential Lane
Symbol
11 S.F.

NOTES:

1. When an arrow and a pavement message are used together, locate the arrow 25' downstream from the pavement message. Measure the distance from the base of the arrow to the base of the pavement message.
2. Place stop message 25' back from the stop line.
3. Dimensions are within 1" ±.
4. All grids are 4" x 4".

PAVEMENT ARROW AND MESSAGE DETAILS

10/14/2016 8:37:55 AM

LAST REVISION 11/01/16	DESCRIPTION:	FY 2017-18 DESIGN STANDARDS	PAVEMENT MARKINGS	INDEX NO. 17346	SHEET NO. 1 of 17
---------------------------	--------------	--------------------------------	-------------------	--------------------	----------------------

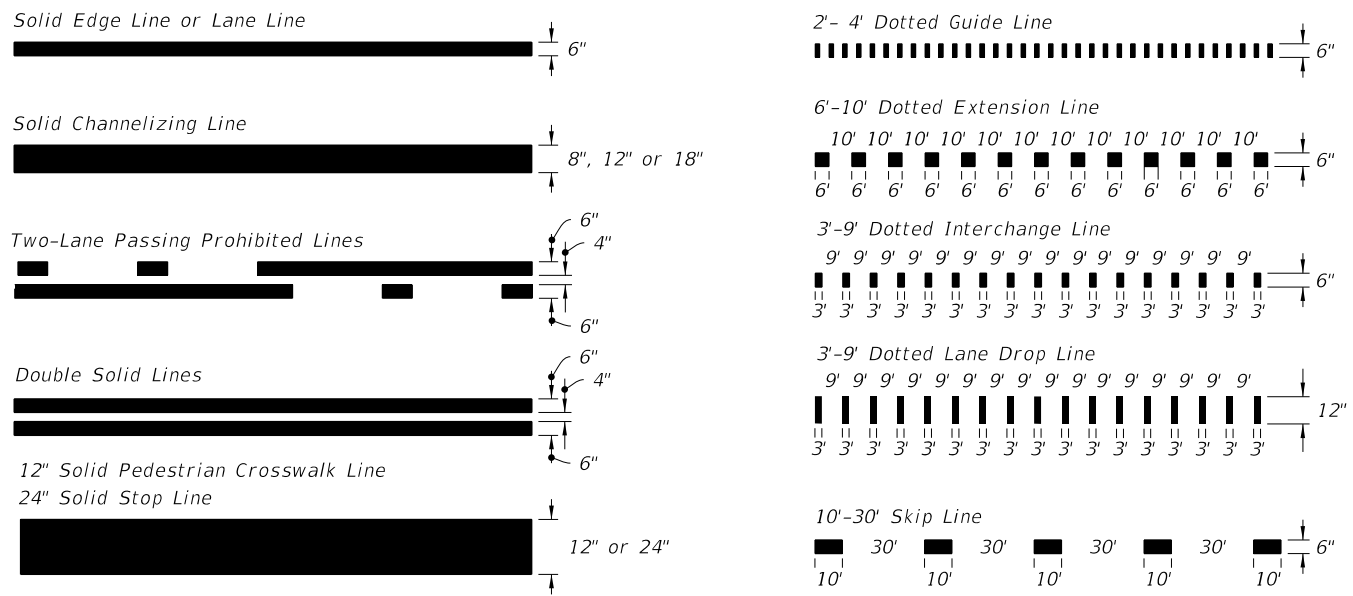

PAVEMENT MARKING LINES

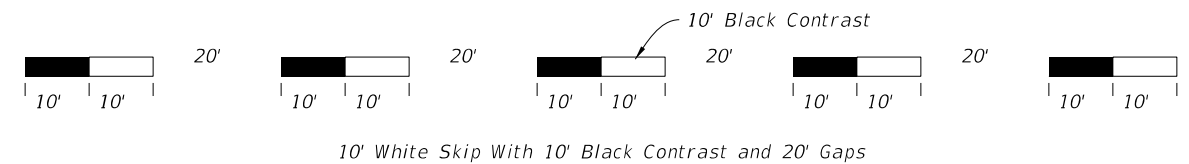

CONTRAST MARKINGS

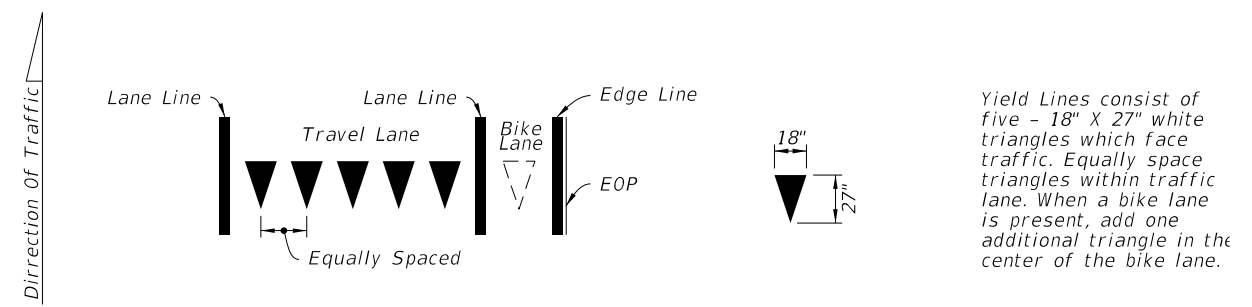

YIELD LINES

10/14/2016 8:37:57 AM

LAST REVISION 11/01/16	DESCRIPTION:	FY 2017-18 DESIGN STANDARDS	PAVEMENT MARKINGS	INDEX NO. 17346	SHEET NO. 2 of 17
---------------------------	--------------	--------------------------------	-------------------	--------------------	----------------------

11/9/2016 8:59:05 AM

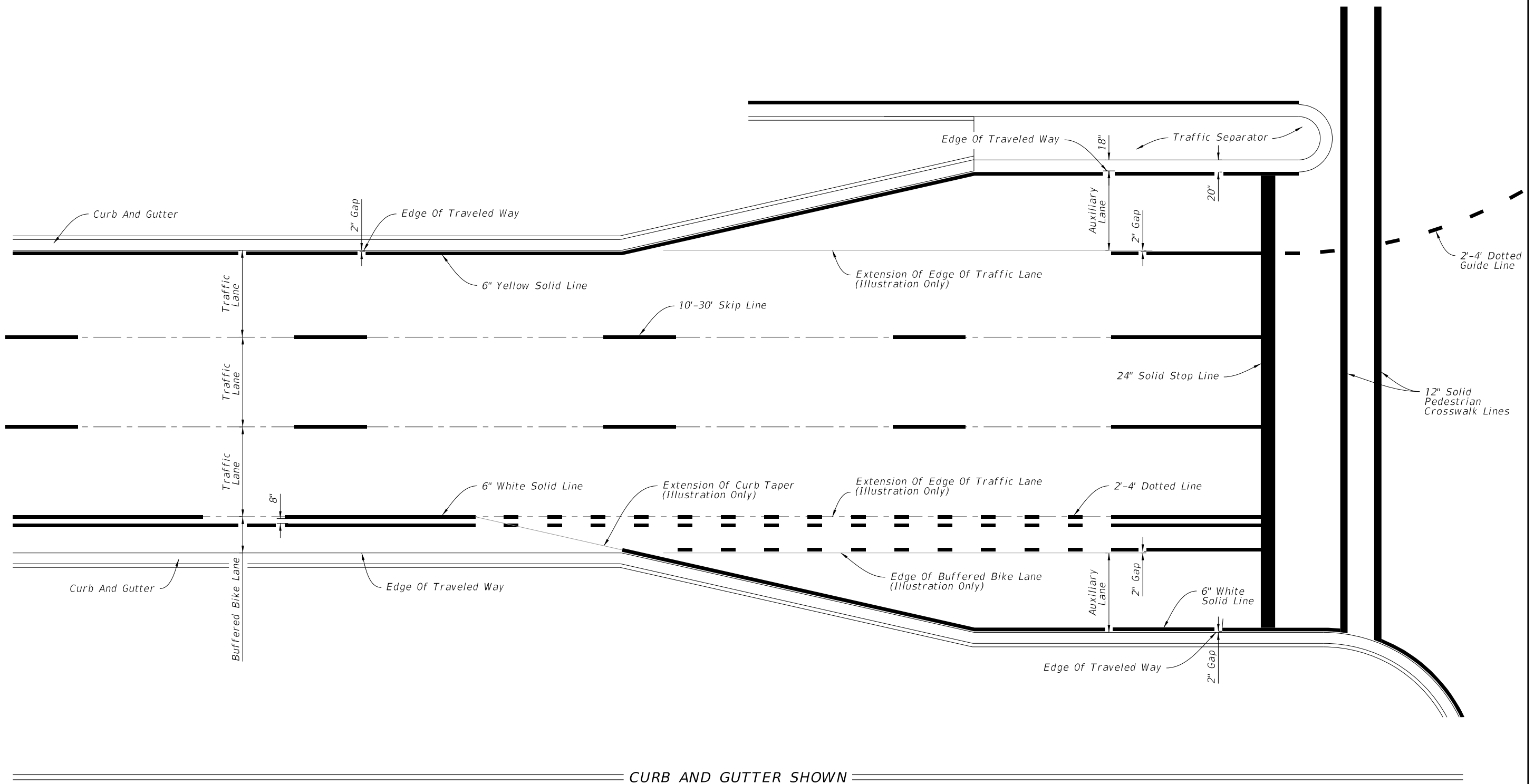

PLACEMENT OF LONGITUDINAL PAVEMENT MARKINGS

LAST REVISION	DESCRIPTION:
11/01/16	



FY 2017-18
DESIGN STANDARDS

PAVEMENT MARKINGS

INDEX NO.
17346

SHEET NO.
3 of 17

11/9/2016 8:59:07 AM

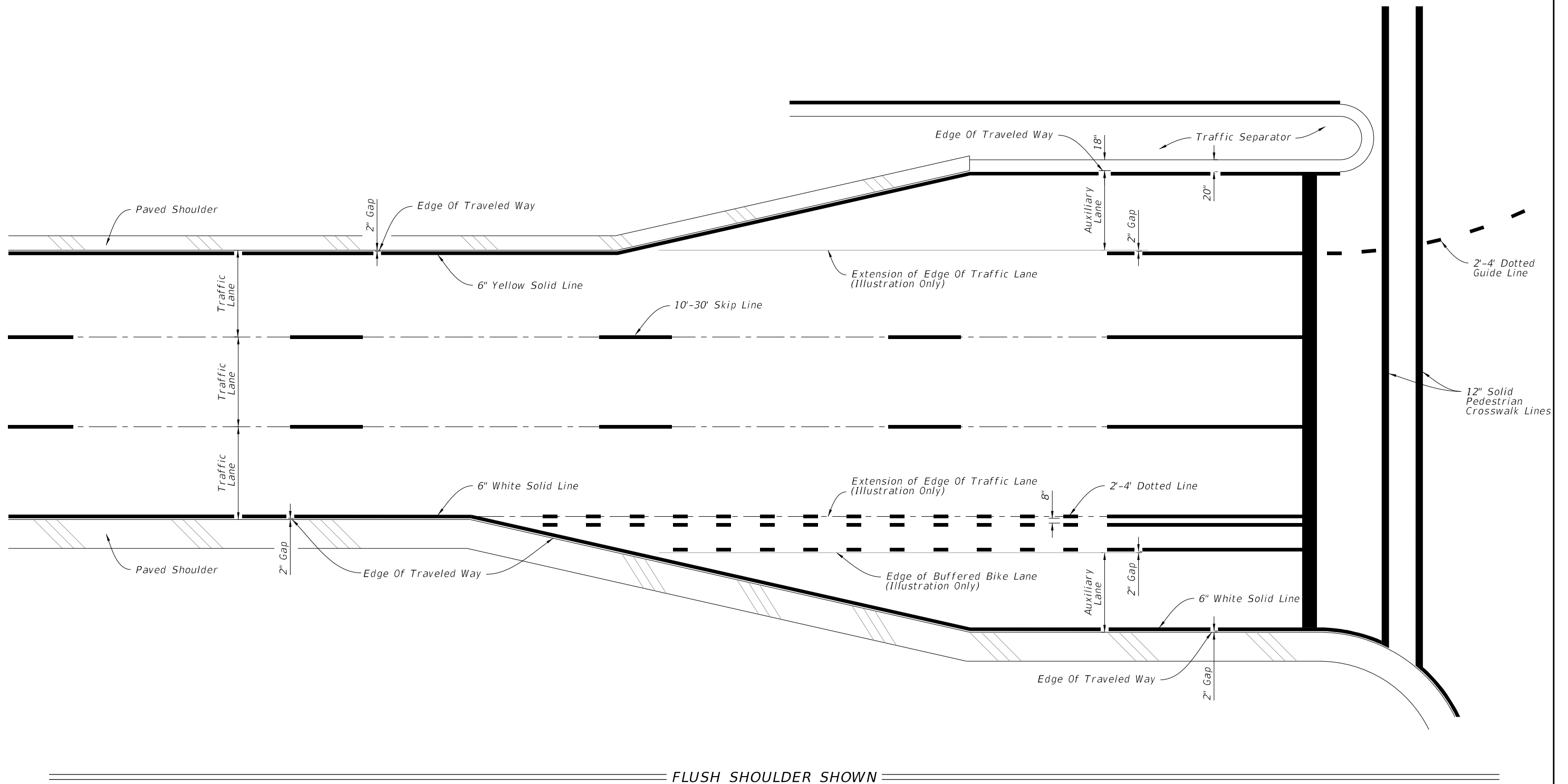

FLUSH SHOULDER SHOWN

PLACEMENT OF LONGITUDINAL PAVEMENT MARKINGS

LAST REVISION 11/01/16	DESCRIPTION:
---------------------------	--------------



FY 2017-18
DESIGN STANDARDS

PAVEMENT MARKINGS

INDEX NO.
17346

SHEET NO.
4 of 17

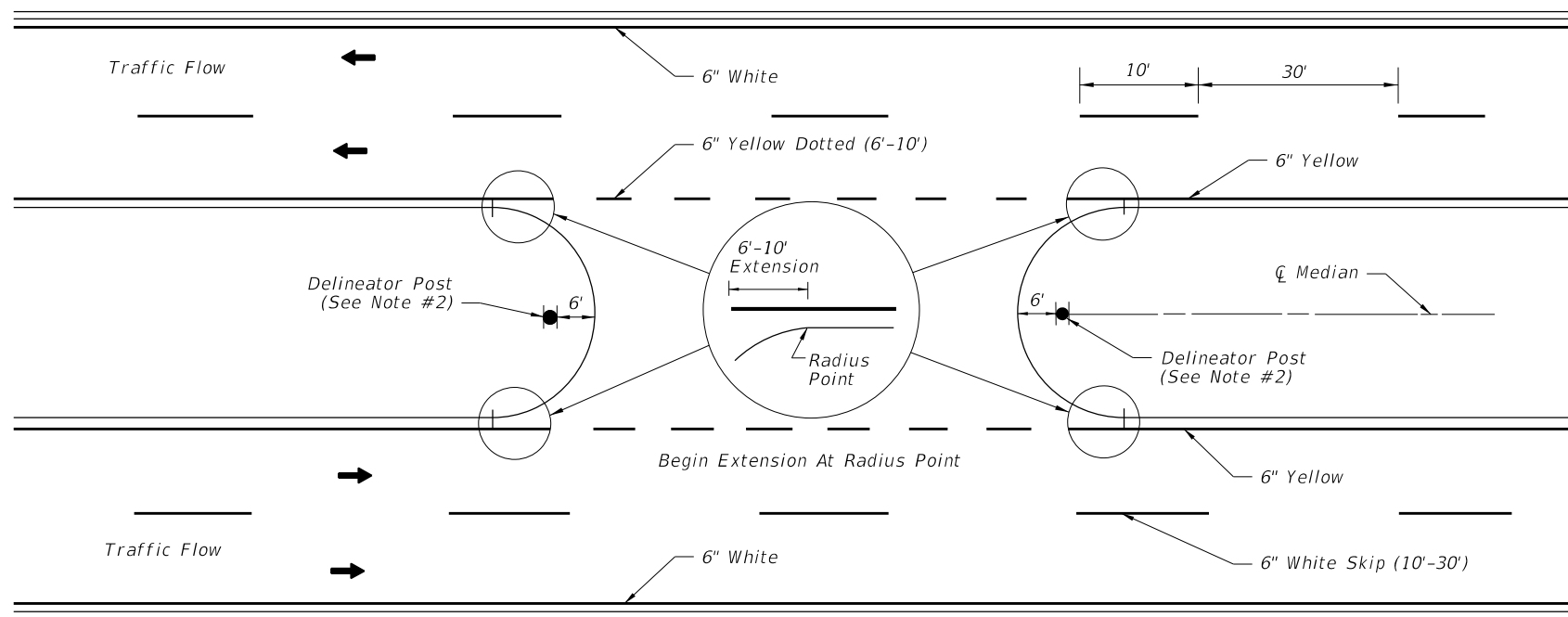

PAVEMENT MARKINGS AND DELINEATORS FOR MEDIAN CROSS-OVER

NOTE:

1. Apply yellow markings to the median noses.
2. Use yellow retro-reflective sheeting on both sides of the delineator. Install the post so that the top is 4' above the grade at the edge of the pavement.

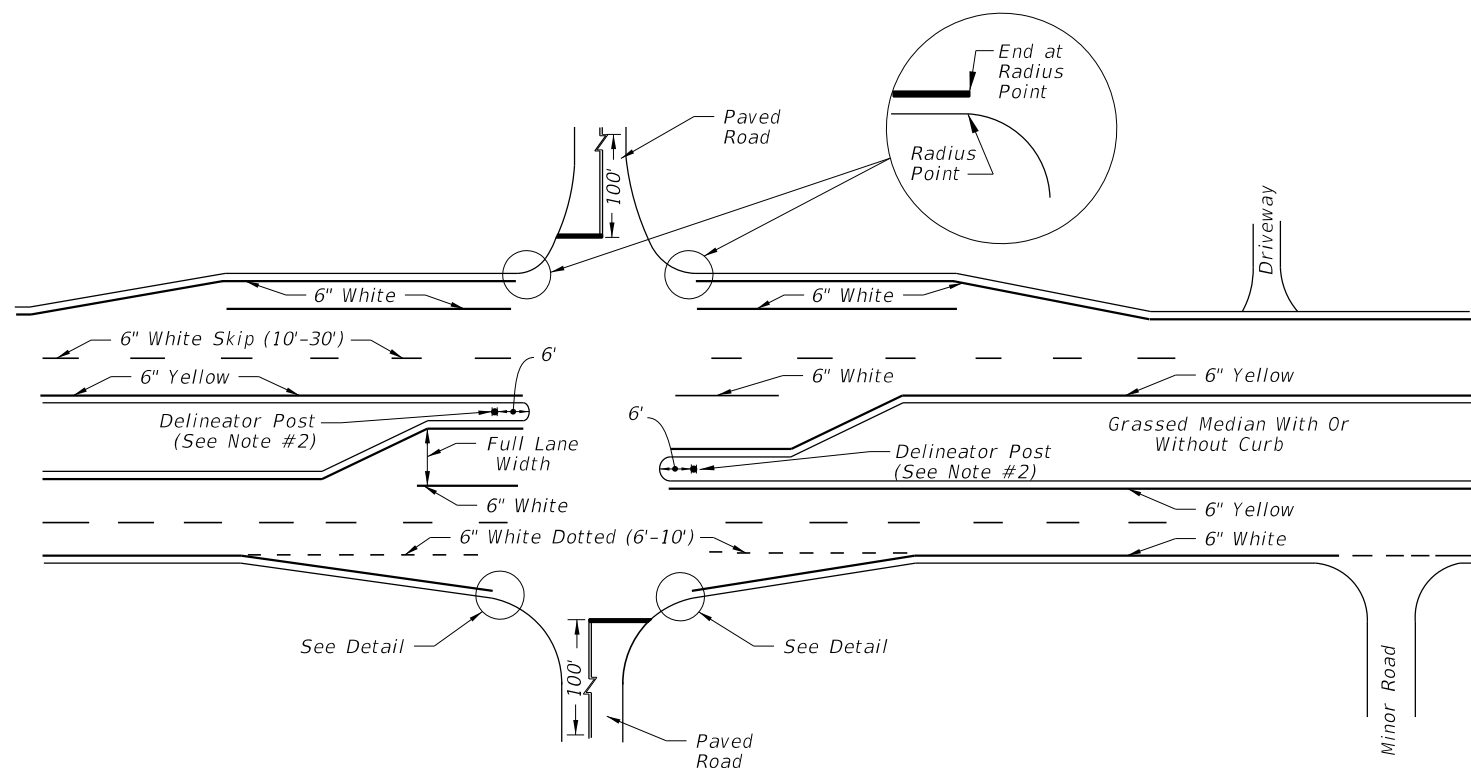

PAVEMENT MARKINGS FOR INTERSECTIONS WITH MAJOR AND MINOR ROADS

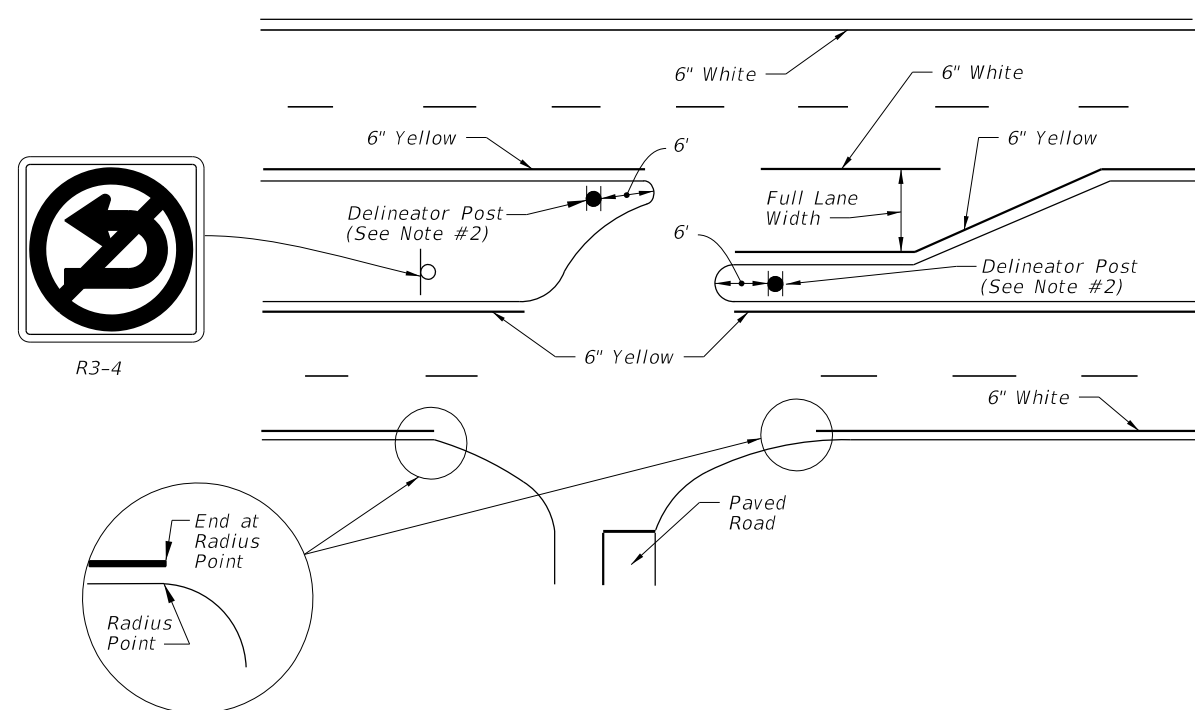

10/14/2016 8:38:03 AM

LAST REVISION 11/01/16	REVISION	DESCRIPTION:
---------------------------	----------	--------------

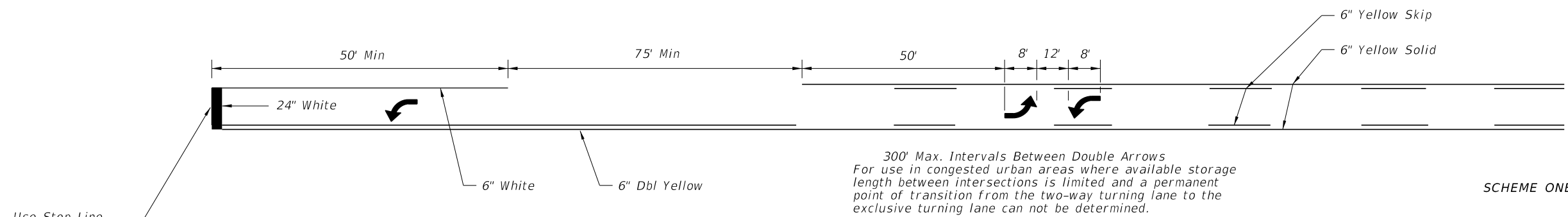

SCHEME ONE

Use Stop Line At Signalized Intersection Only

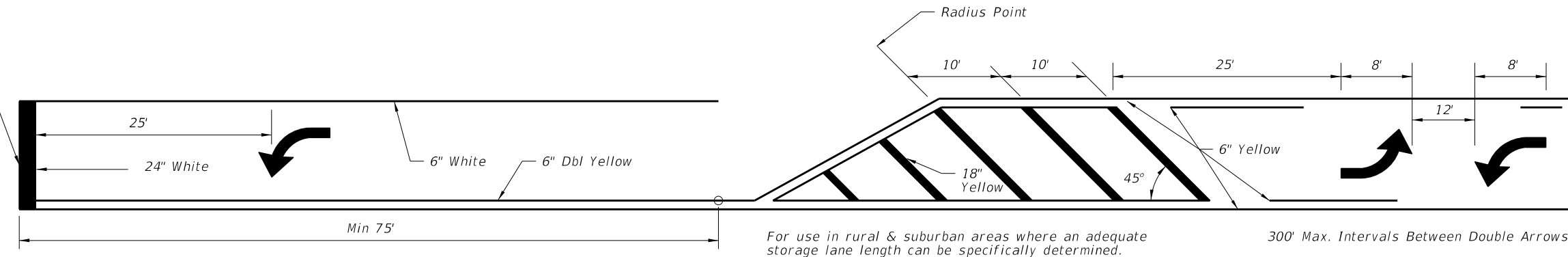

300' Max. Intervals Between Double Arrows

(WITH SINGLE LANE LEFT TURN CHANNELIZATION)
TWO WAY LEFT TURN LANE

SCHEME TWO

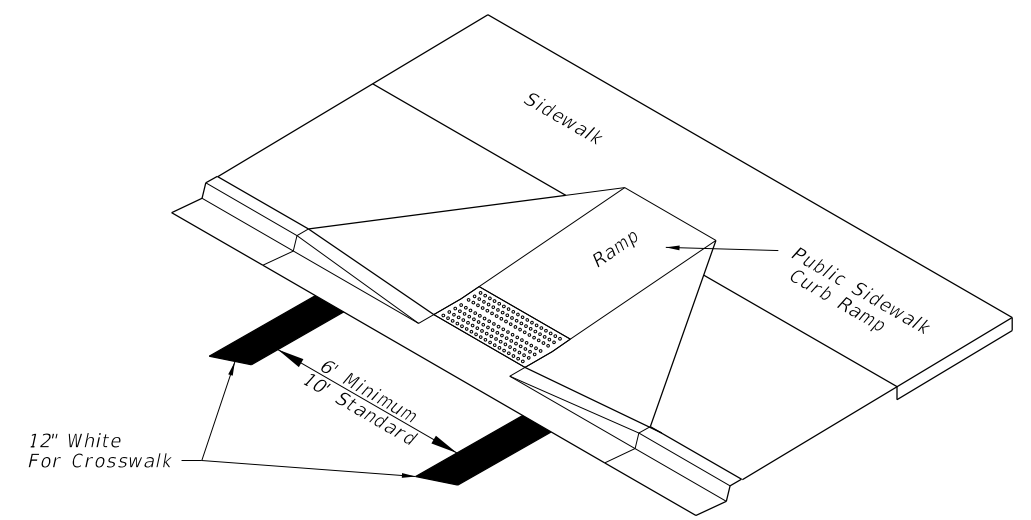
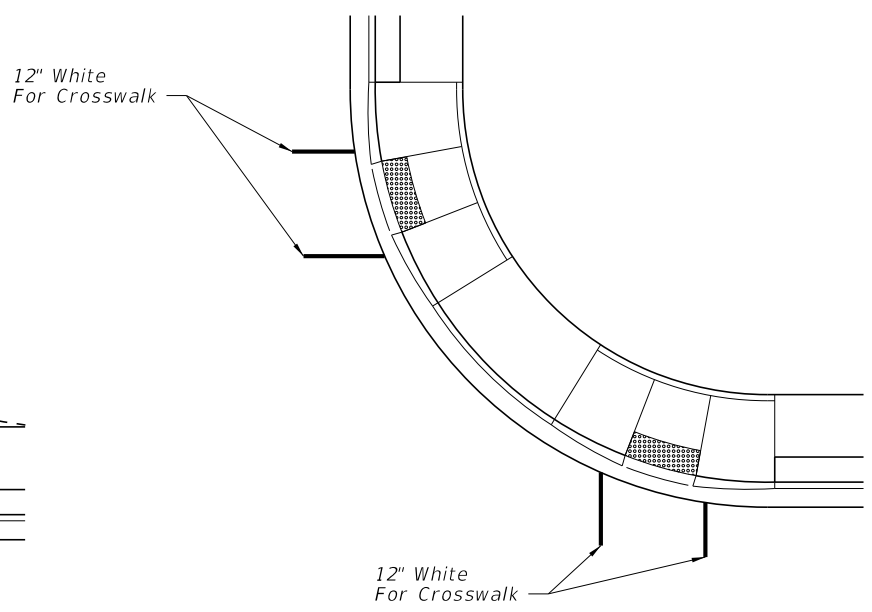
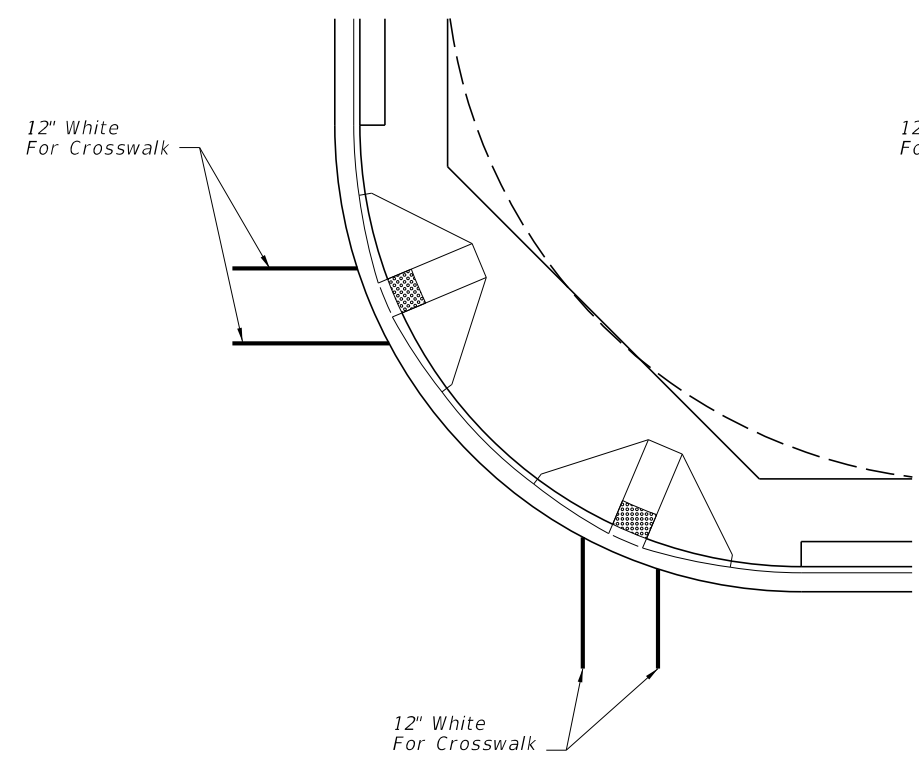

TYPICAL CROSSWALK MARKINGS FOR CURB RAMP

10/14/2016 8:38:05 AM

LAST REVISION 11/01/16	DESCRIPTION:	 FY 2017-18 DESIGN STANDARDS	PAVEMENT MARKINGS	INDEX NO. 17346	SHEET NO. 6 of 17

6'-10' Dotted
6" White

These markings may be used for locations with restricted left turn lengths, only when called for in plans.

6" Dbl Yellow

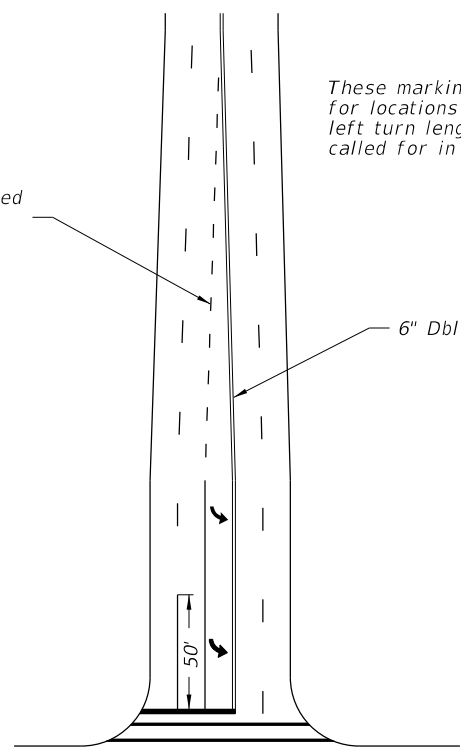

RESTRICTED LEFT TURN MARKING

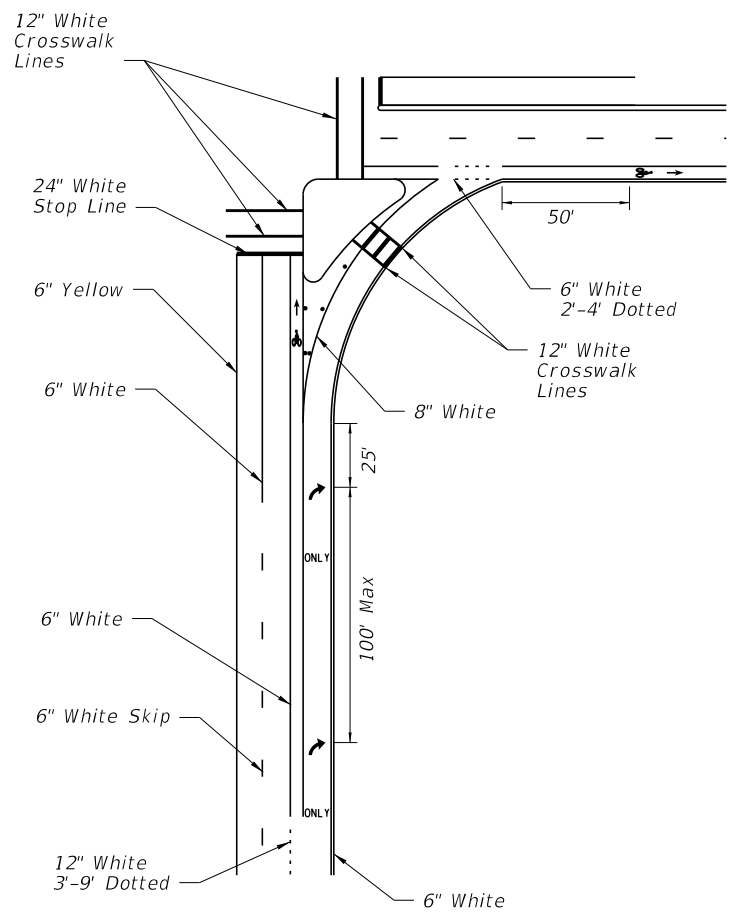

RIGHT TURN LANE DROP AND ISLAND DETAILS
LEFT TURN LANE DROP IS MIRROR IMAGE

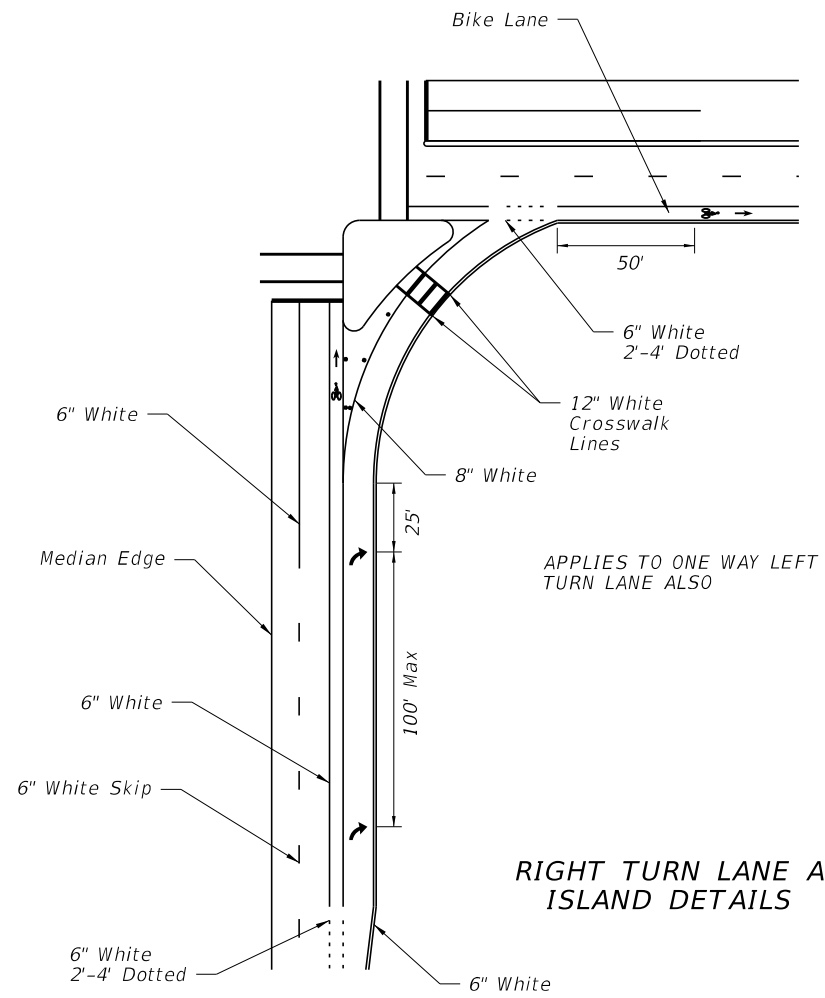

APPLIES TO ONE WAY LEFT TURN LANE ALSO

RIGHT TURN LANE AND ISLAND DETAILS

100' Minimum or as determined by L=WS

($L = \frac{WS^2}{60} < 45 \text{ mph}$) where

W is the lateral offset in feet and S is the 85th percentile speed in miles per hour (speed limit)

For left turn storage lane detail see Sheet 11 of this index.

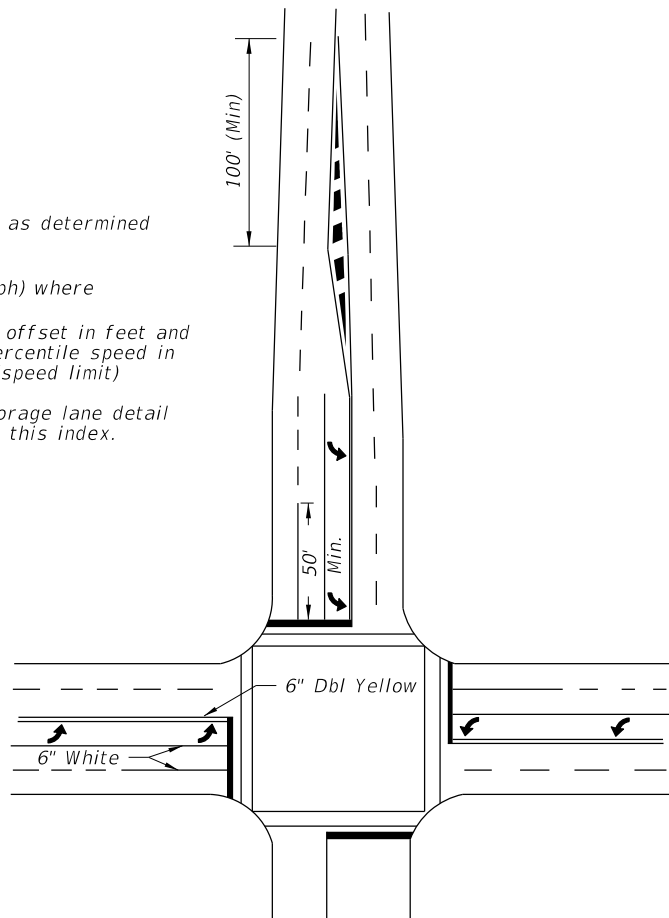

TYPICAL INTERSECTION 2 THRU LANES PLUS LEFT TURN LANE, WITH CROSSWALK

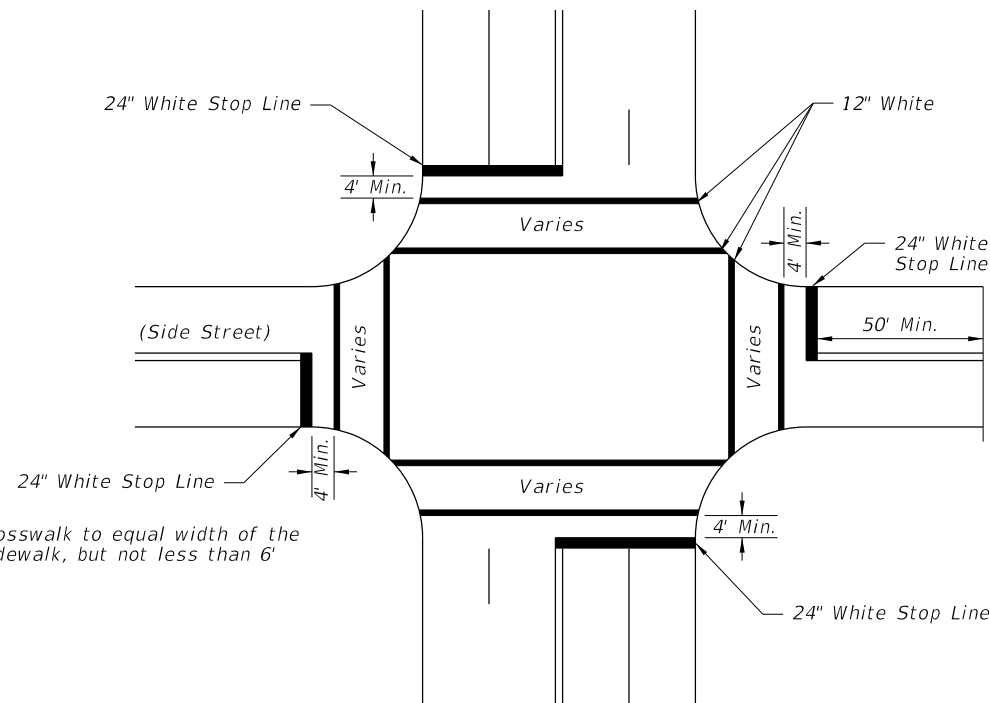

Width of crosswalk to equal width of the adjacent sidewalk, but not less than 6'

STOP BARS, CROSSWALKS AND DOUBLE CENTER LINE DETAILS

NOTES:

1. When public sidewalk curb ramps are present, refer Index No. 17344 and Index No. 304 for crosswalk widths.
2. Double yellow longitudinal center lines on all roadway approaches shall be extended back 100' for projects involving intersection improvements only.
3. When specified, "stop" message shall be placed 25' back of stop lines.

10/14/2016 8:38:07 AM

LAST REVISION 11/01/16	DESCRIPTION:
---------------------------	--------------

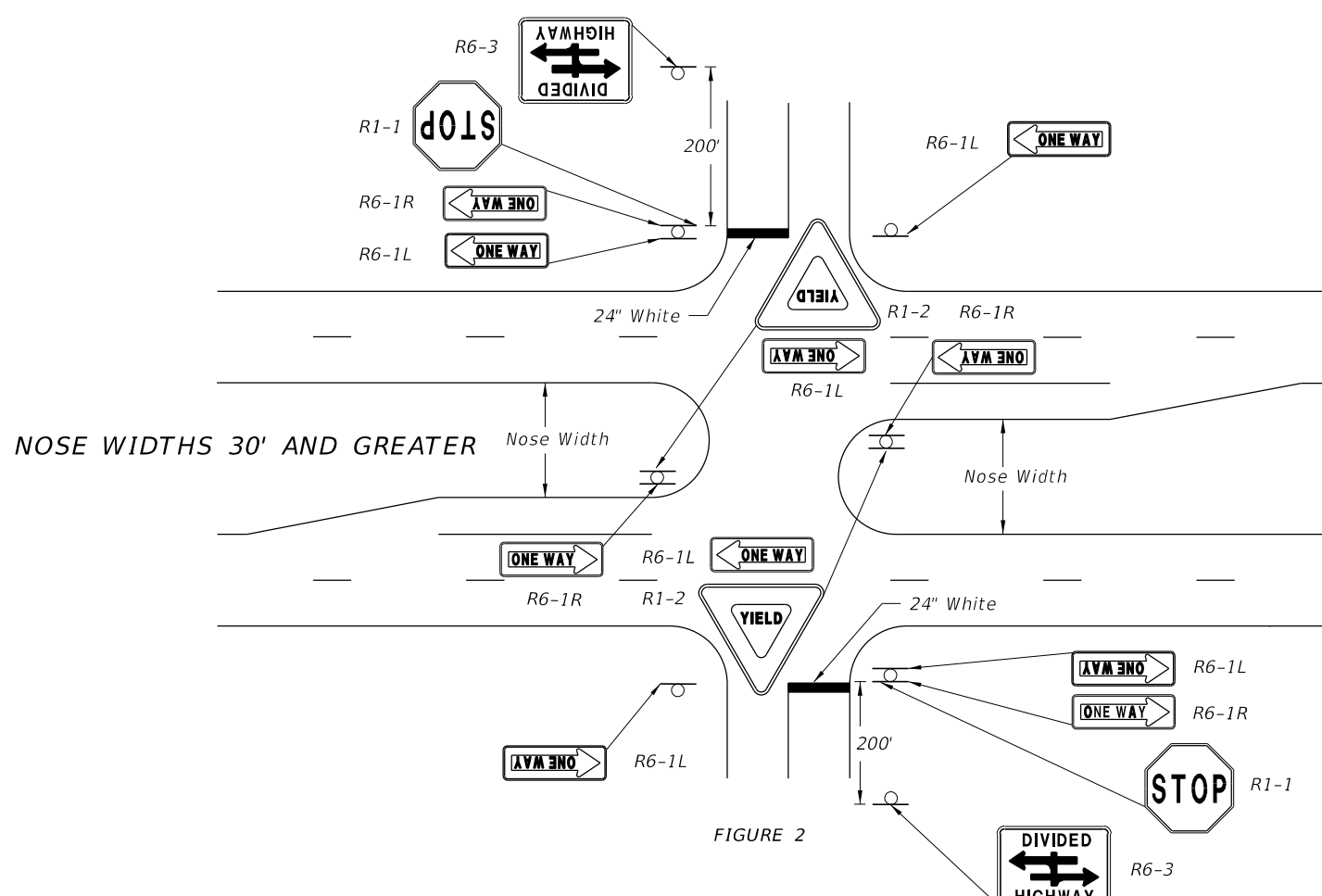
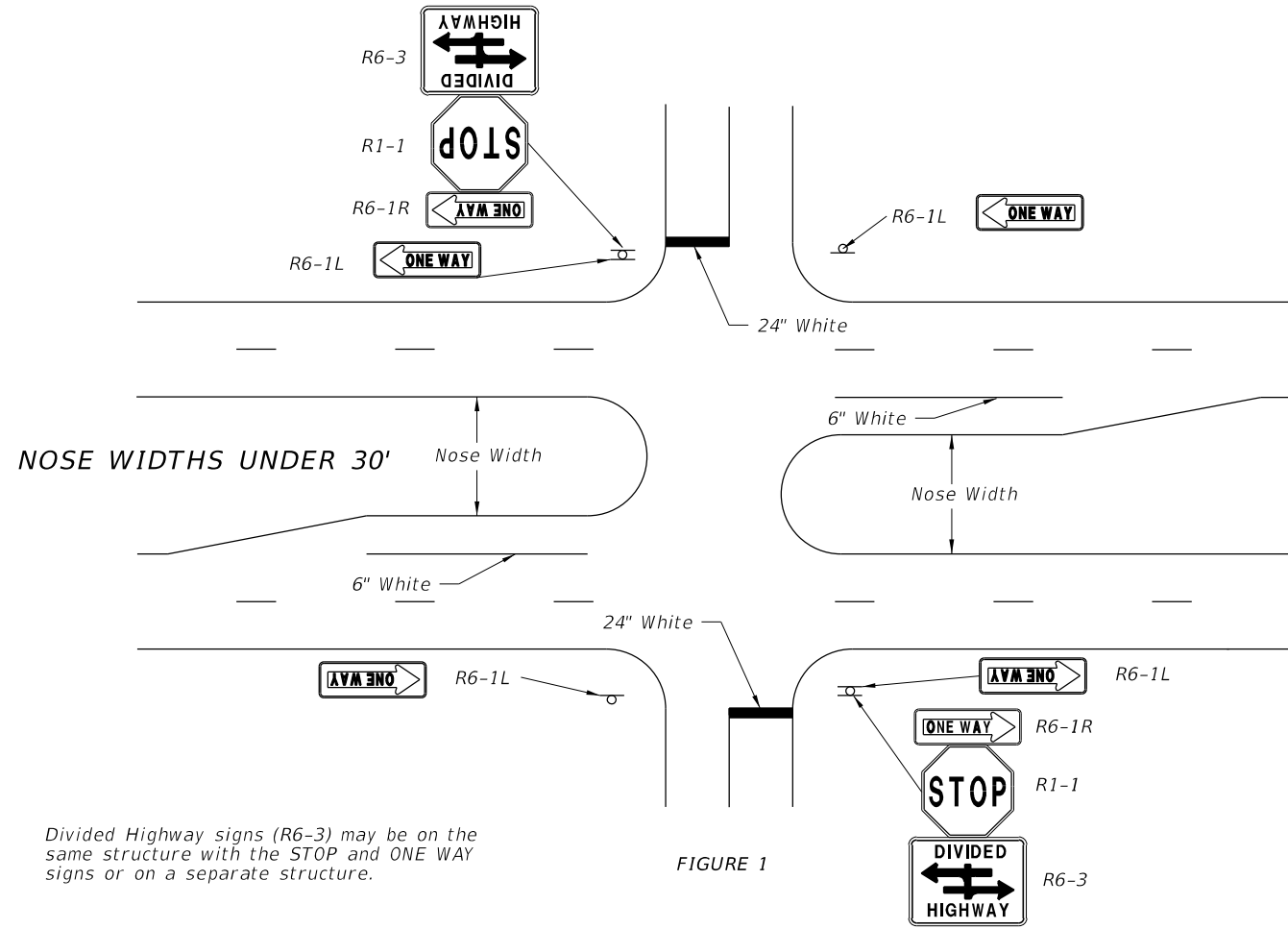

Divided Highway signs (R6-3) may be on the same structure with the STOP and ONE WAY signs or on a separate structure.

FIGURE 1

FIGURE 2

ONE-WAY SIGNS ON DIVIDED HIGHWAY INTERSECTIONS

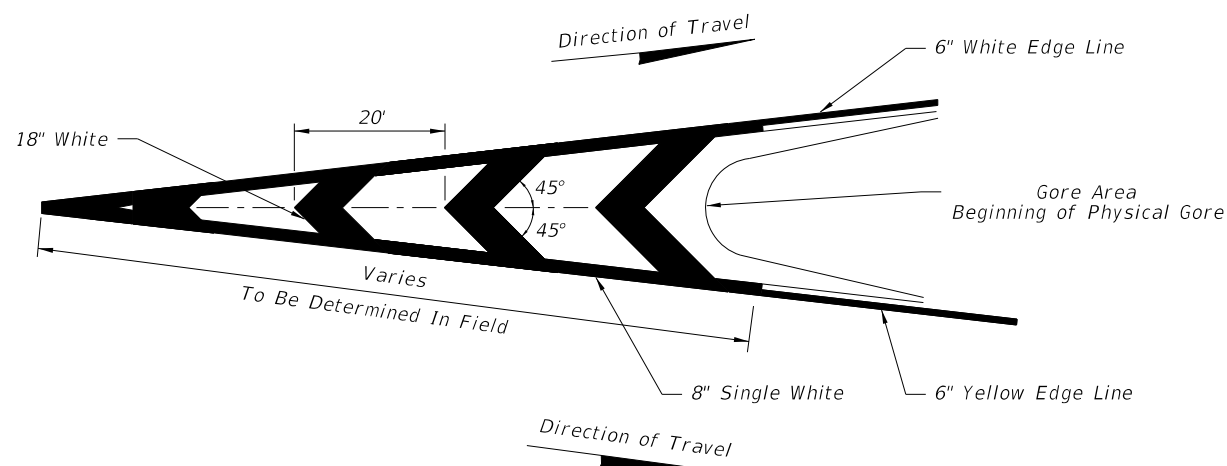

PAVEMENT MARKINGS FOR TRAFFIC CHANNELIZATION AT GORE
(TRAFFIC FLOWS IN SAME DIRECTION)

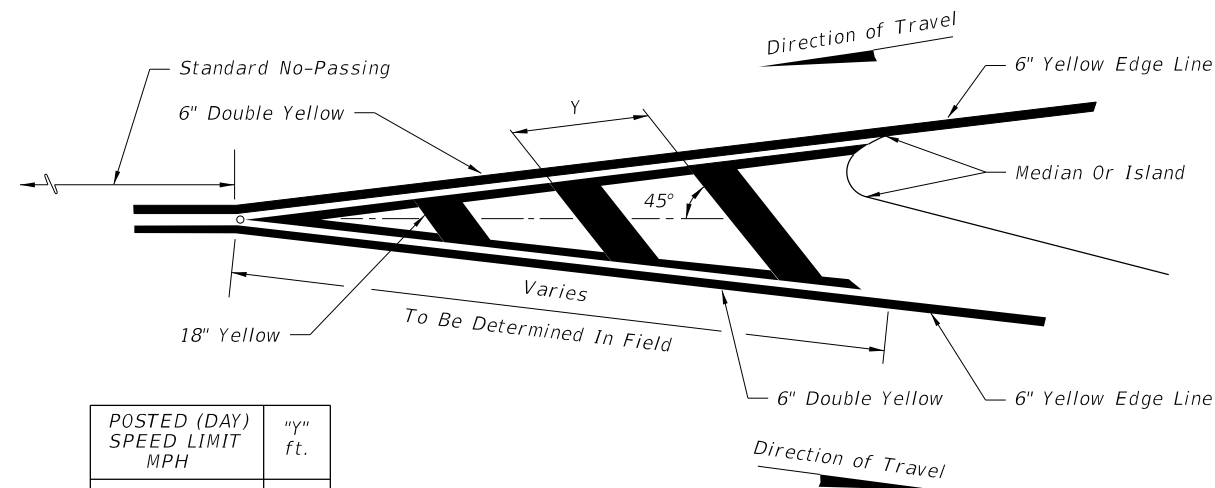

PAVEMENT MARKING FOR TRAFFIC SEPARATION
(TRAFFIC FLOWS IN OPPOSING DIRECTIONS)

10/14/2016 8:38:09 AM

LAST REVISION 11/01/16

REVISION

DESCRIPTION:



FY 2017-18 DESIGN STANDARDS

PAVEMENT MARKINGS

INDEX NO. 17346

SHEET NO. 8 of 17

TYPICAL TRANSITION MARKING
 COLOR SHALL BE THE SAME AS RESPECTIVE EDGE LINE

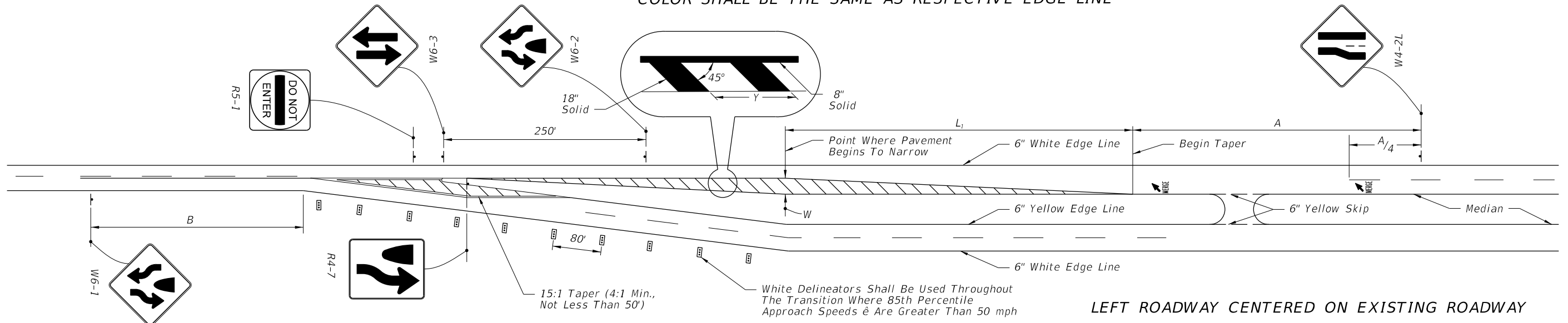

LEFT ROADWAY CENTERED ON EXISTING ROADWAY

**W	TRANSITION DISTANCE L ₁ (FEET)						
*S	8	9	10	11	12	13	14
30	120	135	150	165	180	195	210
35	165	185	205	225	245	265	285
40	215	240	270	295	320	350	375
45	360	405	450	495	540	585	630
50	400	450	500	550	600	650	700
55	440	495	550	605	660	715	770
60	480	540	600	660	720	780	840
65	520	585	650	715	780	845	910

SPEED* MPH	"A" (FT.)	"B" (FT.)
60	---	640
55	950	595
50	850	550
45	750	500
40	650	455
30	450	365

POSTED (DAY) SPEED LIMIT MPH	"Y" (FT.)
30 OR LESS	10
35	20
40	20
45	30
50 OR MORE	40

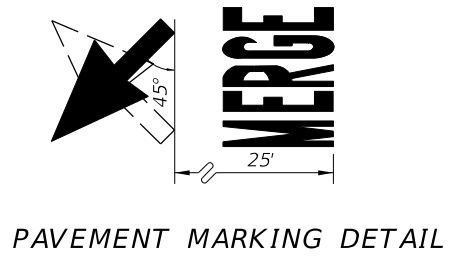
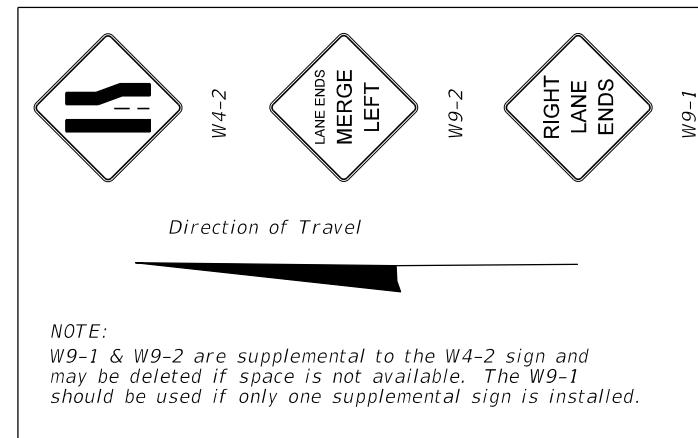

PAVEMENT MARKING DETAIL

$L_1 = WS$ (45 MPH or Greater) *Design Speed
 $L_1 = \frac{WS^2}{60}$ (≤ 40 MPH) **Lateral offset

White Delineators Shall Be Used Throughout The Transition Where 85th Percentile Approach Speeds* Are Greater Than 50 mph.

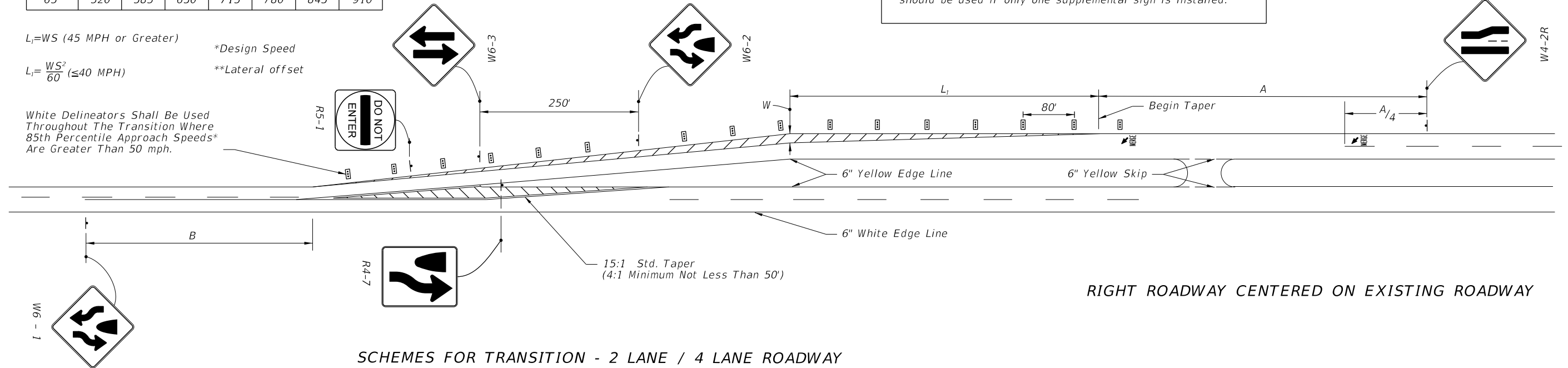

RIGHT ROADWAY CENTERED ON EXISTING ROADWAY

SCHEMES FOR TRANSITION - 2 LANE / 4 LANE ROADWAY

10/14/2016 8:38:11 AM

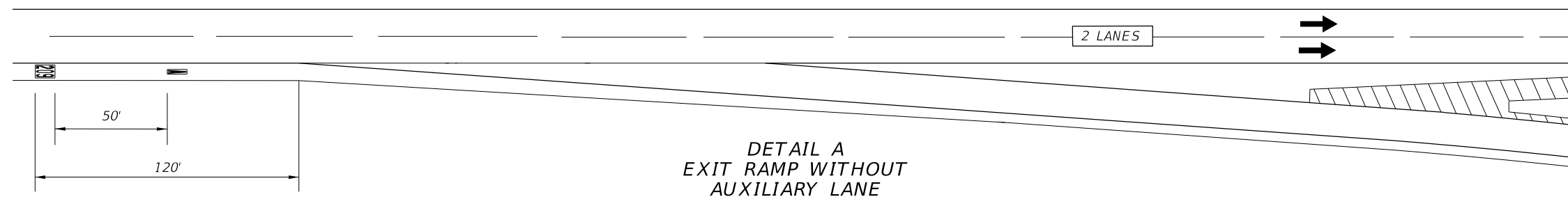

DETAIL A
EXIT RAMP WITHOUT
AUXILIARY LANE

LAYOUT FOR 1, 2 AND 3 DIGIT NUMBERS AND LETTERS

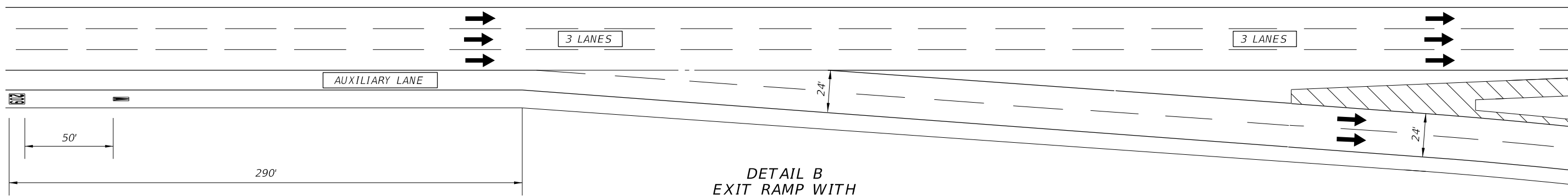

DETAIL B
EXIT RAMP WITH
AUXILIARY LANE

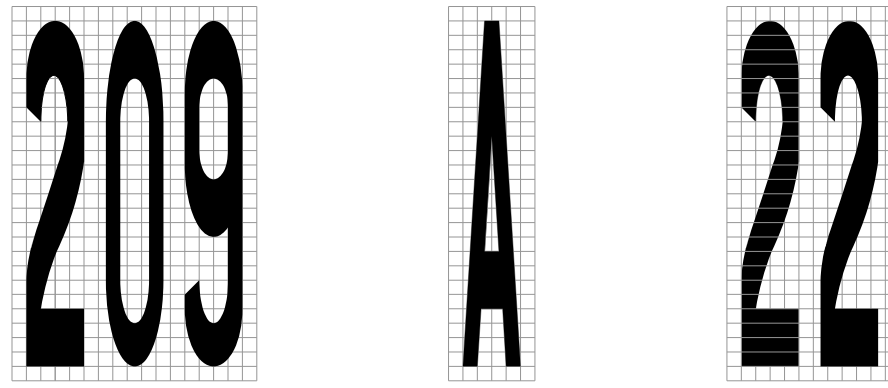

MESSAGE SIZE AND SPACING
4" X 4" squares

NOTES:

1. Messages shall meet requirements of Specification Section 971-6 and Section 711.
2. The thickness of the preformed message shall be 125 mils.
3. The message shall consist of white letters and numbers with black contrasting material. The black material shall meet the mat dimensions shown and have a minimum skid resistance value of 55 BPN.
4. The "EXIT NUMBER" position remains the same distance from the beginning of taper regardless of the number of lines of information.

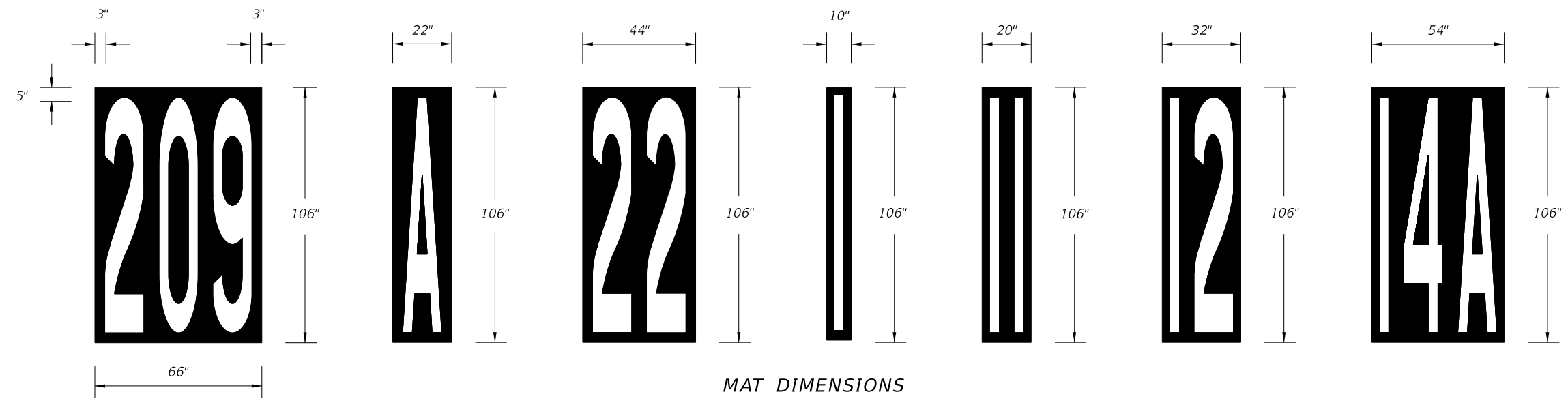

MAT DIMENSIONS

10/14/2016 8:38:13 AM

LAST REVISION 11/01/16	REVISION	DESCRIPTION:	 FY 2017-18 DESIGN STANDARDS	PAVEMENT MARKINGS	INDEX NO. 17346	SHEET NO. 10 of 17
---------------------------	----------	--------------	---	-------------------	--------------------	-----------------------

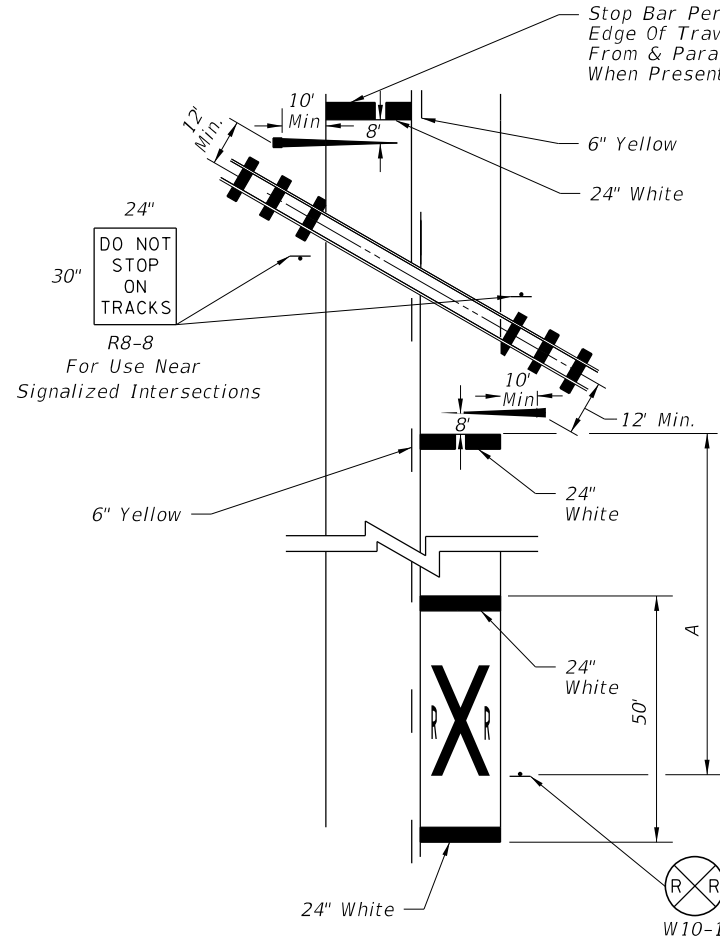

RAILROAD CROSSING AT 2-LANE ROADWAY

The Railroad Traffic Control Device Is To Be Located A Minimum Of 12' From The Railroad Centerline. See Index No. 17882 For Protection Devices.

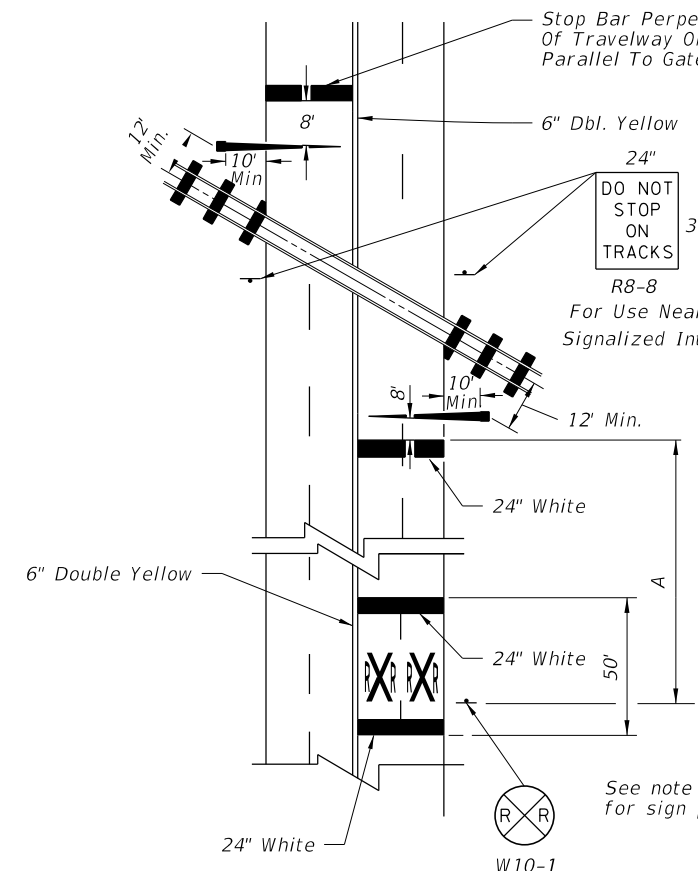

RAILROAD CROSSING AT 4-LANE ROADWAY

The Railroad Traffic Control Device Is To Be Located A Minimum Of 12' From The Railroad Centerline. See Index No. 17882 For Protection Devices.

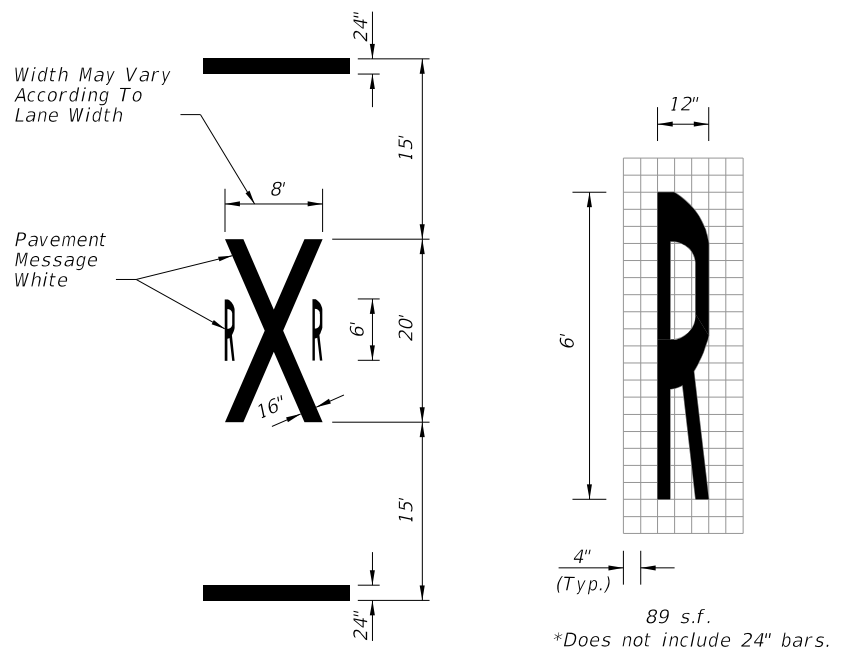

TYPICAL PAVEMENT MARKINGS FOR R/R CROSSING

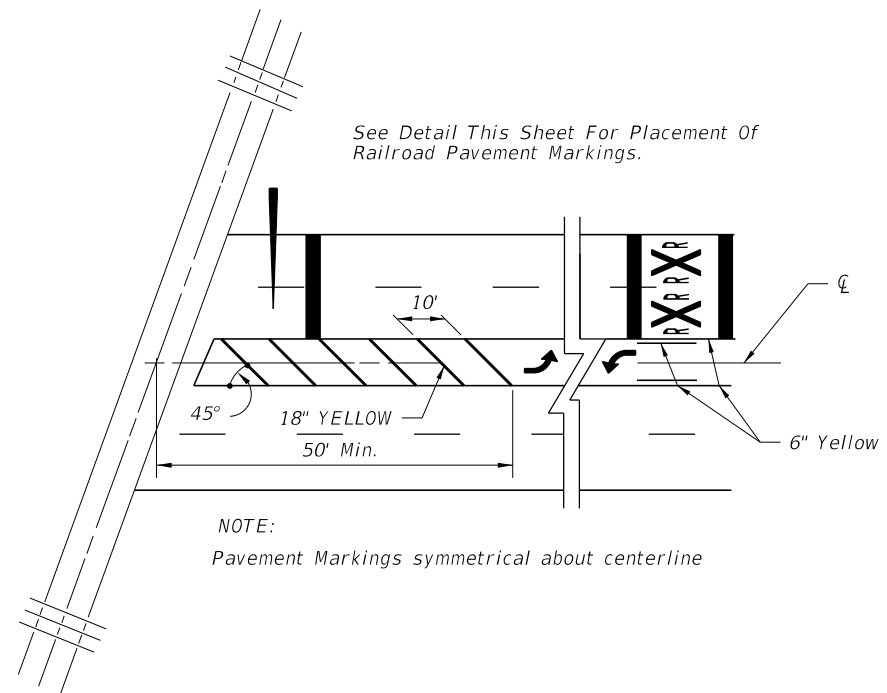

PAVEMENT MARKINGS FOR TERMINATION OF TWO WAY LEFT TURN AT R/R CROSSINGS

NOTES:

1. When computing pavement messages, quantities do not include transverse lines.
2. When dynamic devices are not present or are to be installed, the crossbuck shall be located at the future location of the RR gate or signal and gate in accordance with Index No. 17882.
3. Placement of sign W10-1 in a residential or business district, where low speeds are prevalent. The W10-1 sign may be placed a minimum distance of 100' from the crossing. Where street intersections occur between the RR pavement message and the tracks an additional W10-1 sign & additional Pavement message should be used.
4. Recommended location for FTP-61-06 or FTP-62-06 sign, 100' urban & 300' rural in advance of the crossing.
5. A portion of the pavement marking symbol should be directly opposite the W10-1 sign.

SPEED MPH	" A " IN FT.
60	400
55	325
50	250
45	175
40	125
35	100
URBAN	85 MIN.

10/14/2016 8:38:16 AM

GENERAL NOTES

1. For traffic and pedestrian signal installation, refer to Index No. 17721 through 17890.
2. For public sidewalk curb ramps, refer to Index No. 304.
3. For pavement marking and sign installation, refer to Indexes 11200 through 17356.
4. Crosswalk minimum widths: Intersection Crosswalk 6'. Midblock Crosswalk 10'.
5. All crosswalk marking must be white.
6. Longitudinal markings in Special Emphasis Crosswalk must be 24" wide and spaced to avoid the wheel path of vehicles (see detail). Center the longitudinal markings at each lane line. Place additional longitudinal markings at the center of each lane (1/2W). The maximum spacing allowed between longitudinal markings is 60".

When the Crosswalk is skewed to the lane lines, the longitudinal markings should be parallel to the lane lines.

24" Longitudinal Bars in Special Emphasis Crosswalk must be preformed thermoplastic.

12" Transverse lines in the Special Emphasis Crosswalk may be standard thermoplastic or preformed thermoplastic.

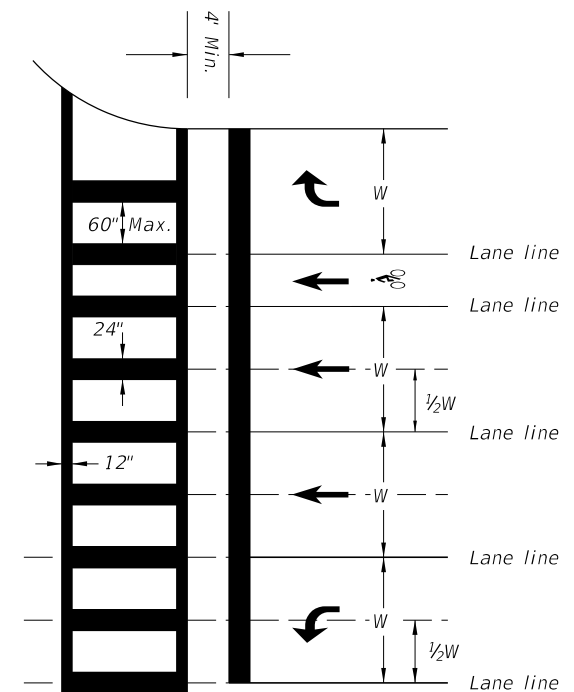
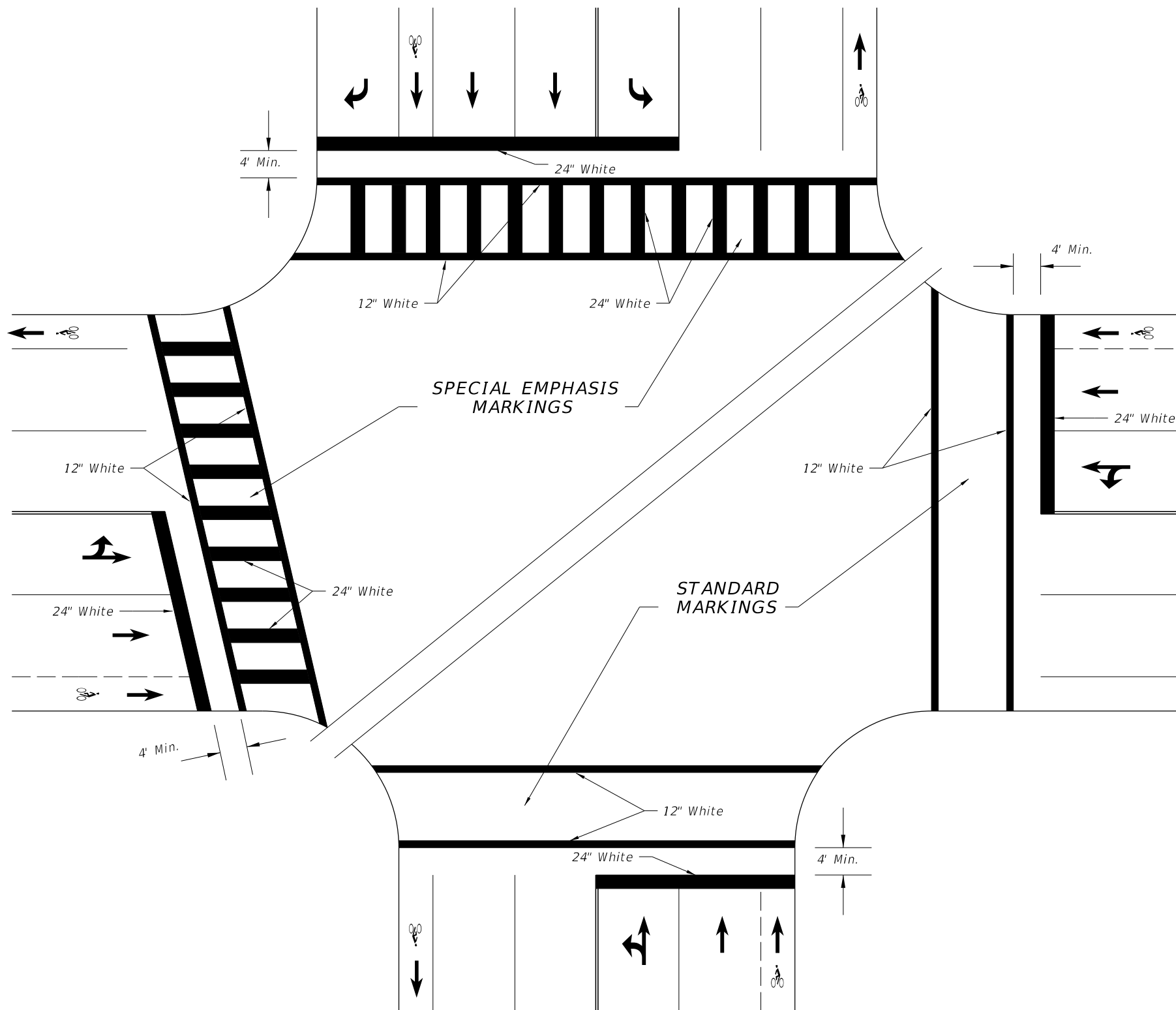

**SPECIAL EMPHASIS AND STANDARD CROSSWALKS
SIGNALIZED OR STOP SIGN CONTROLLED INTERSECTION**

10/14/2016 8:38:19 AM

LAST REVISION 11/01/16	DESCRIPTION:	 FY 2017-18 DESIGN STANDARDS	PAVEMENT MARKINGS	INDEX NO. 17346	SHEET NO. 12 of 17
---------------------------	--------------	--	-------------------	--------------------	-----------------------

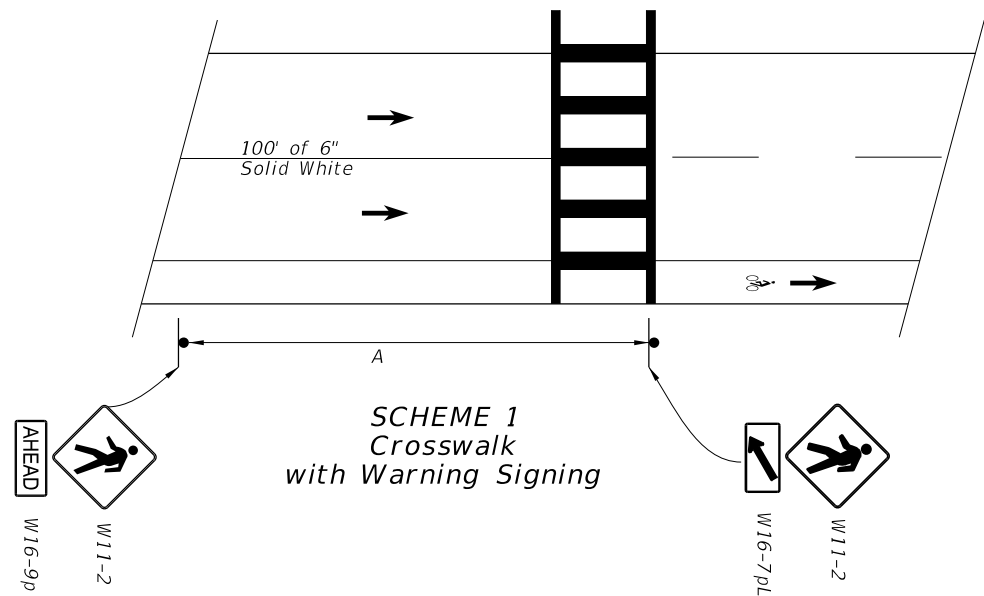

SCHEME 1
Crosswalk
with Warning Signing

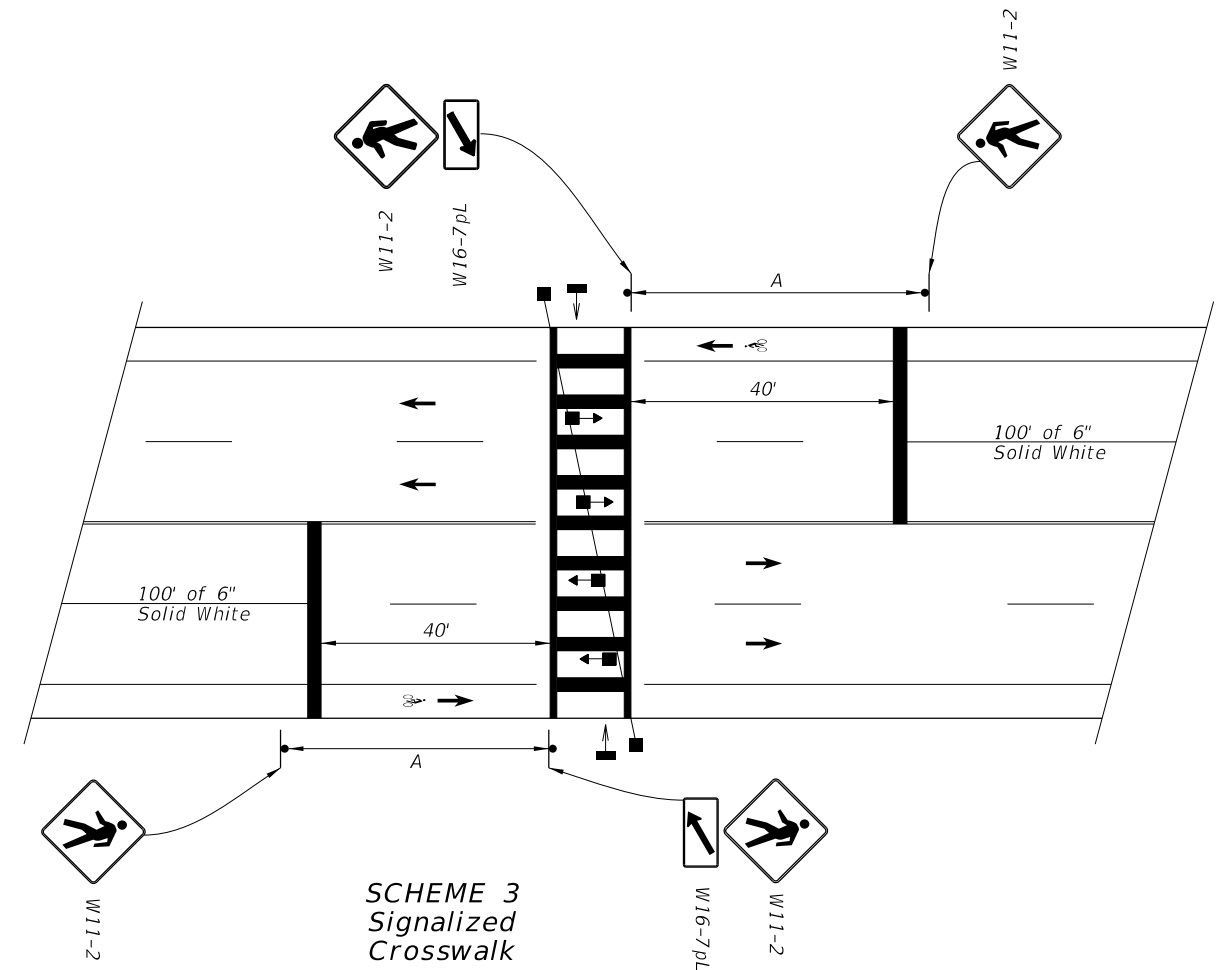

SCHEME 3
Signalized
Crosswalk

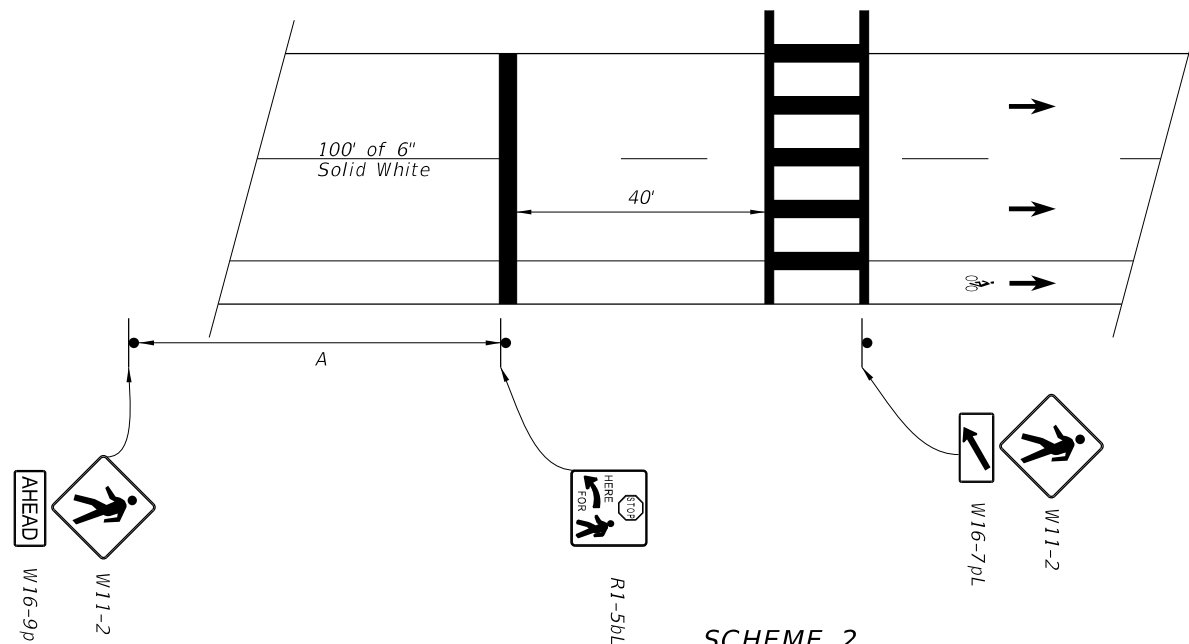

SCHEME 2
Crosswalk
with Stop Signing

APPROACH SPEED MPH	A-SUGGESTED DISTANCE (Ft.)
25 Or Less	200
26 To 35	250
36 To 45	300

1. Plans shall indicate which crosswalk scheme is to be used.
2. The details shown do not depict the signing and markings for multi-lane roadways with divided medians. For these applications, additional signs shall be installed on the median side. Minimum width of Mid-Block Crosswalks is 10'.
3. All mid-block crosswalks shall use special emphasis crosswalk markings.
4. Crosswalk marking shall be performed marking materials.

10/14/2016 8:38:20 AM

LAST REVISION	DESCRIPTION:
11/01/16	

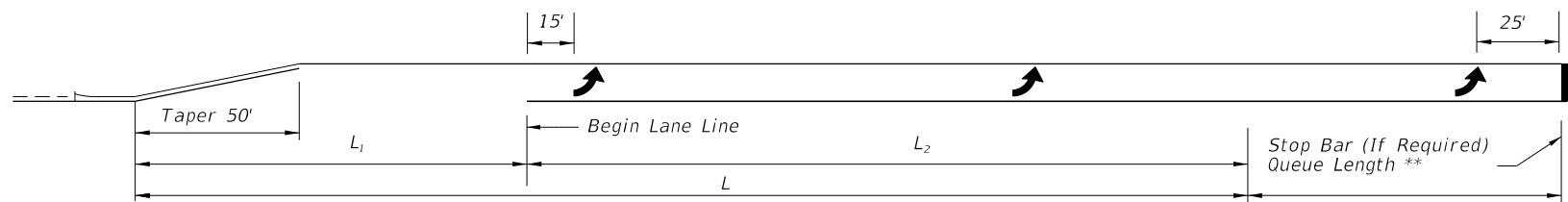

SINGLE LEFT TURNS

** Queue Length Is Measured From The Median Nose Radial Point Or, When A Stop Bar Is Required, From The Stop Bar.

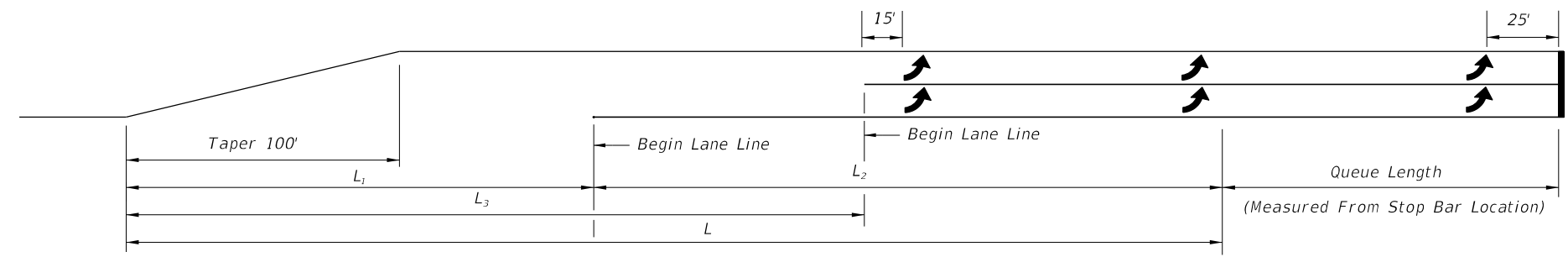

DOUBLE LEFT TURNS

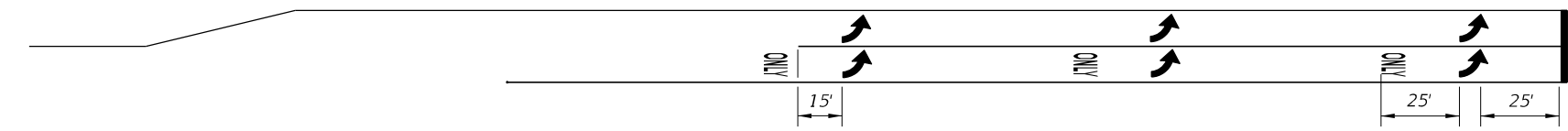

Through Lane Becomes Exclusive Left Turn

The ONLY pavement message is required for turn lanes, where the thru lane becomes turn lane.

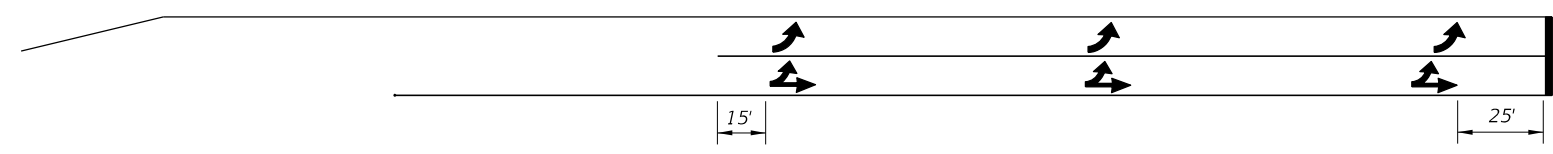

Through Lane Becomes Optional Left Turn

DOUBLE LEFT TURN MARKINGS

TURN LANES - CURBED AND UNCURBED MEDIANS							
Design Speed (mph)	Clearance Distance	URBAN CONDITIONS			RURAL CONDITIONS		
		Brake To Stop Distance	Total Decel. Distance	Clearance Distance	Brake To Stop Distance	Total Decel. Distance	Clearance Distance
	L ₁	L ₂	L	L ₃	L ₂	L	L ₃
35	70'	75'	145'	110'	---	---	---
40	80'	75'	155'	120'	---	---	---
45	85'	100'	185'	135'	---	---	---
50	105'	135'	240'	160'	185'	290'	160'
55	125'	---	---	---	225'	350'	195'
60	145'	---	---	---	260'	405'	230'
65	170'	---	---	---	290'	460'	270'

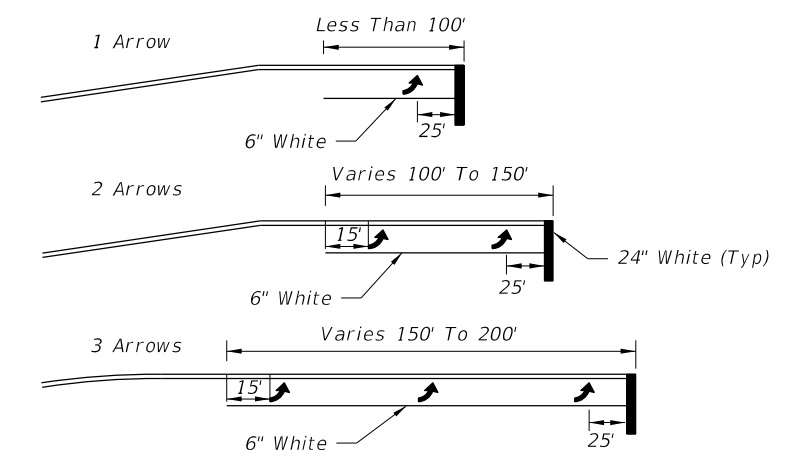

Arrow should be evenly spaced between first and last arrow. Turn lanes longer than 200' add one arrow for each 100' additional length.

ARROW SPACING

NOTES:

1. The "Begin Lane Line" locations are based on the standard lengths shown in Design Standard 301. These locations must be adjusted on a case by case basis for turn lanes not meeting the standard lengths.
2. Yellow left turn edge marking may be used adjacent to raised curb or grass medians if lane use is not readily apparent to drivers approaching a left turn storage lane.
3. Refer to Design Standard Index 301 for Roadway Details.
4. This Index also applies to right turn lanes.

10/14/2016 8:38:22 AM

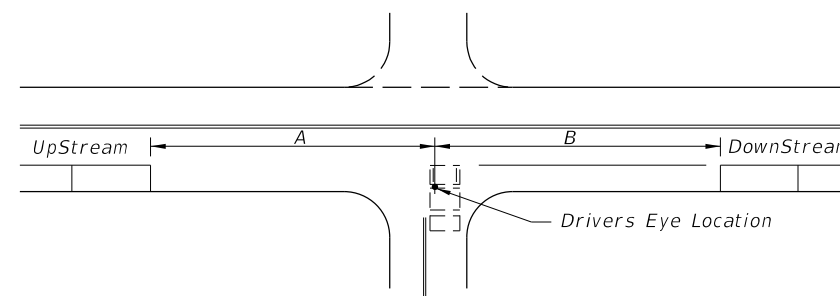
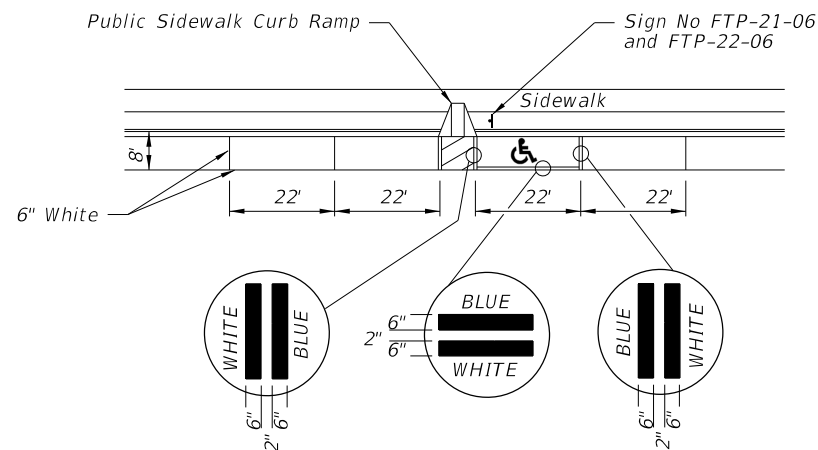

GENERAL NOTES (Signalized & Nonsignalized)

1. For entrances to a one-way street, the downstream restriction may be reduced to 20'.
2. Parking shall not be allowed within 20' of a crosswalk.
3. All parking lane markings shall be 6" white.
4. Parking lane lines shall be broken at driveways.
5. Refer to Chapter 316, Fla. Statutes, for laws governing parking spaces.
6. Where curb and gutter is used, the gutter pan width may be included as part of the minimum width of parking lane, but desirably the lane width should be in addition to that of the gutter pan.

SPEED MPH	UP STREAM (A)	DOWN STREAM (B)	
		2 LANE	4 LANE
0-30	85'	60'	45'
35	100'	70'	50'

NOTES

1. Distances measured longitudinally along the street from driver location of entering vehicle to end of parking restriction.
2. Distances applicable to intersecting street, major driveways and other driveways to the extent practical.
3. For nonsignalized intersections, the values above shall be compared with the values for signalized intersections and the maximum restrictions implemented. These restrictions apply to both accessible and nonaccessible parking.

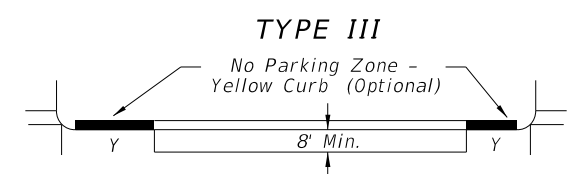
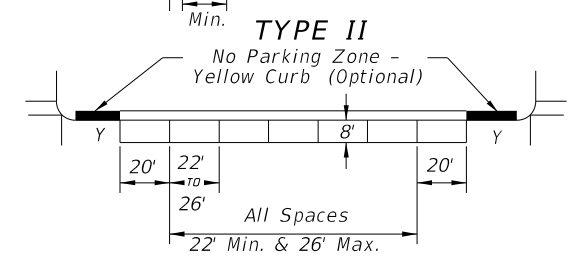
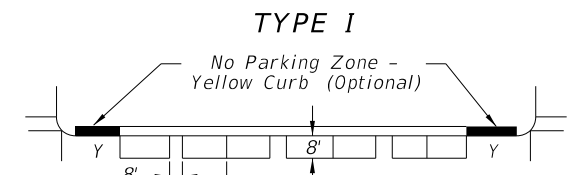
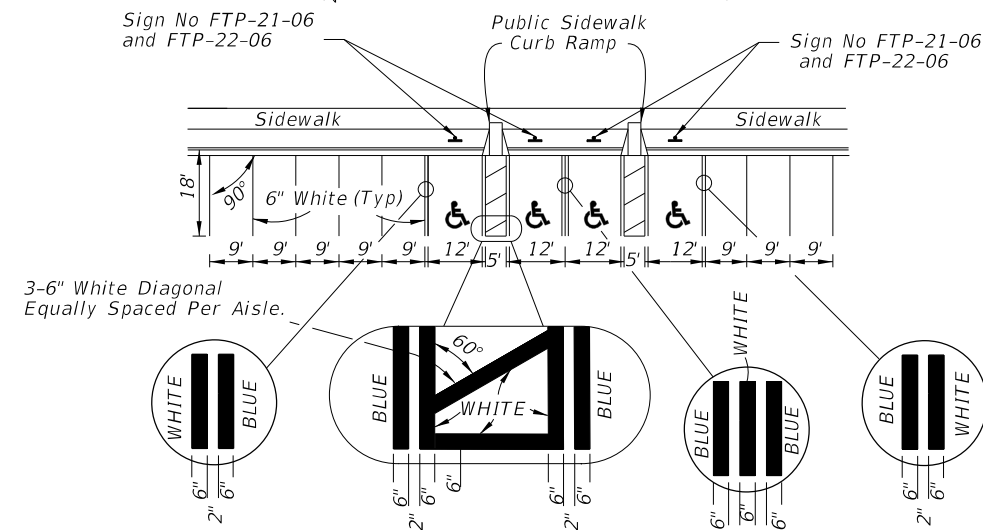

MINIMUM PARKING RESTRICTION FOR NONSIGNALIZED INTERSECTIONS

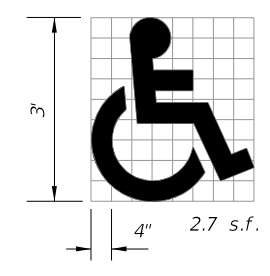
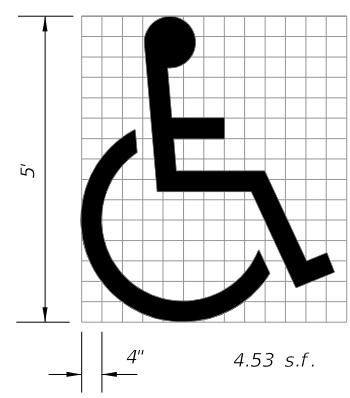

Use of pavement symbol in accessible parking spaces is optional, when used the symbol shall be 3' or 5' high and white in color.

UNIVERSAL SYMBOL OF ACCESSIBILITY

SPEED LIMIT MPH	SIGNALIZED INTERSECTIONS	DISTANCE FROM CURB RADIUS (Y)
0-30	30'	
35	50'	

PARKING RESTRICTION (FT.) FOR SIGNALIZED INTERSECTION

NOTES:

1. Parking restrictions measured from curb radius point.
2. Restrictions for accessible parking are the same as those applied to nonsignalized intersections.

MINIMUM PARKING RESTRICTION FOR SIGNALIZED INTERSECTION

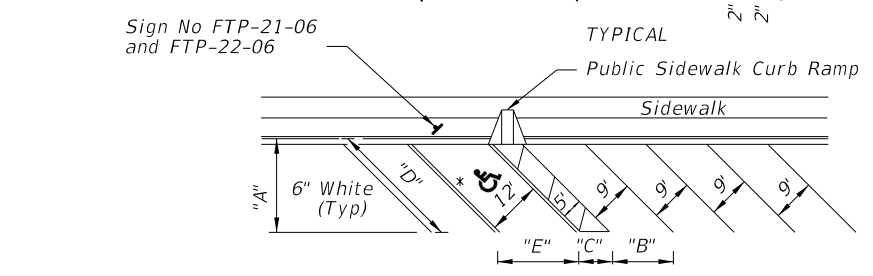

* FOR ACCESSIBLE MARKINGS - SEE ABOVE

"DIMENSIONS"					
∠ θ	"A"	"B"	"C"	"D"	"E"
45°	19'-1"	12'-9"	7'-0"	27'-0"	17'-0"
60°	20'-1"	10'-5"	5'-9"	23'-2"	13'-10"

- NOTES:**
1. Dimensions are to the centerline of markings.
 2. An Access Aisle is required for each accessible space when angle parking is used.
 3. Criteria for pavement markings only, not public sidewalk curb ramp locations. For ramp locations refer to plans.
 4. Blue pavement markings shall be tinted to match shade 15180 of Federal Standards 595a.
 5. The FTP-22-06 panel shall be mounted below the FTP-21-06 sign.

PAVEMENT MARKING FOR PUBLIC SIDEWALK CURB RAMPS IN REST AREAS

10/14/2016 8:38:24 AM

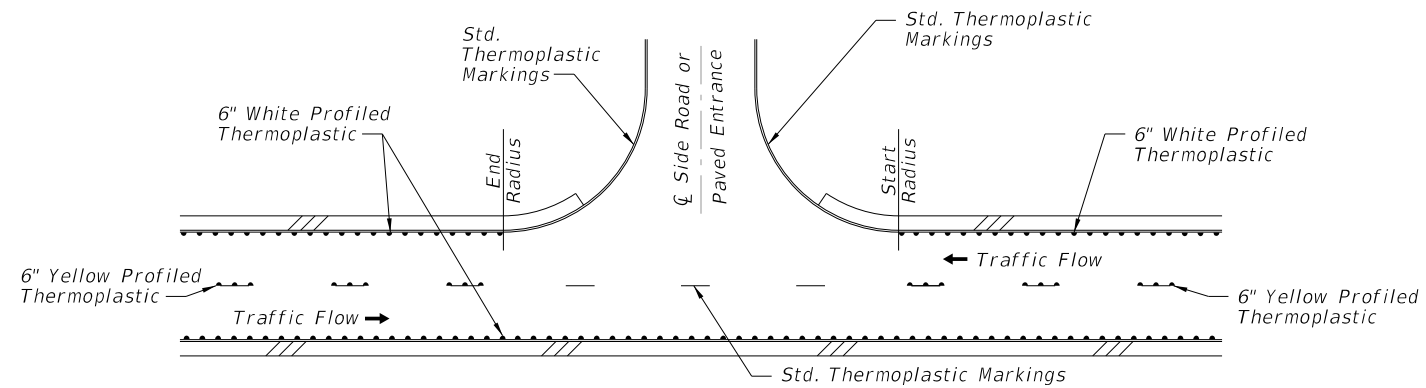

TYPICAL RURAL INTERSECTION WITHOUT TURN LANES

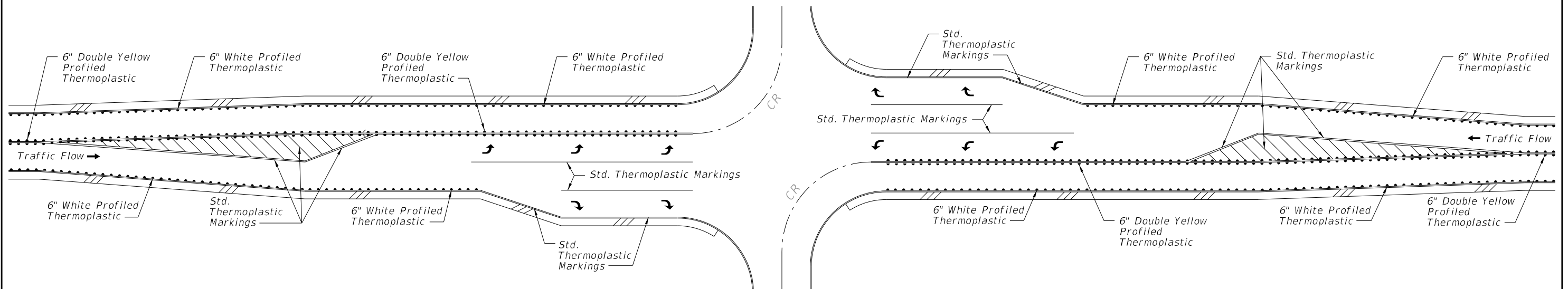

TYPICAL RURAL INTERSECTION WITH TURN LANES

GENERAL NOTES:

1. Remove raised retroreflective pavement markers when in conflict with the installation of the centerline profiled thermoplastic pavement markings. The cost of removal is included in the cost of the profiled thermoplastic pavement marking.
2. Replacement of retroreflective pavement markers removed during the installation of the centerline profiled thermoplastic pavement markings will be paid for under Pay Item 706.

10/14/2016 8:38:27 AM

PROFILED THERMOPLASTIC MARKINGS 2 LANE ROADWAYS

LAST REVISION 11/01/16	REVISION	DESCRIPTION:	 FY 2017-18 DESIGN STANDARDS	PAVEMENT MARKINGS	INDEX NO. 17346	SHEET NO. 16 of 17
---------------------------	----------	--------------	---	-------------------	--------------------	-----------------------

REFERENCE:
See Profiled Thermoplastic Markings General Notes on Sheet 13.

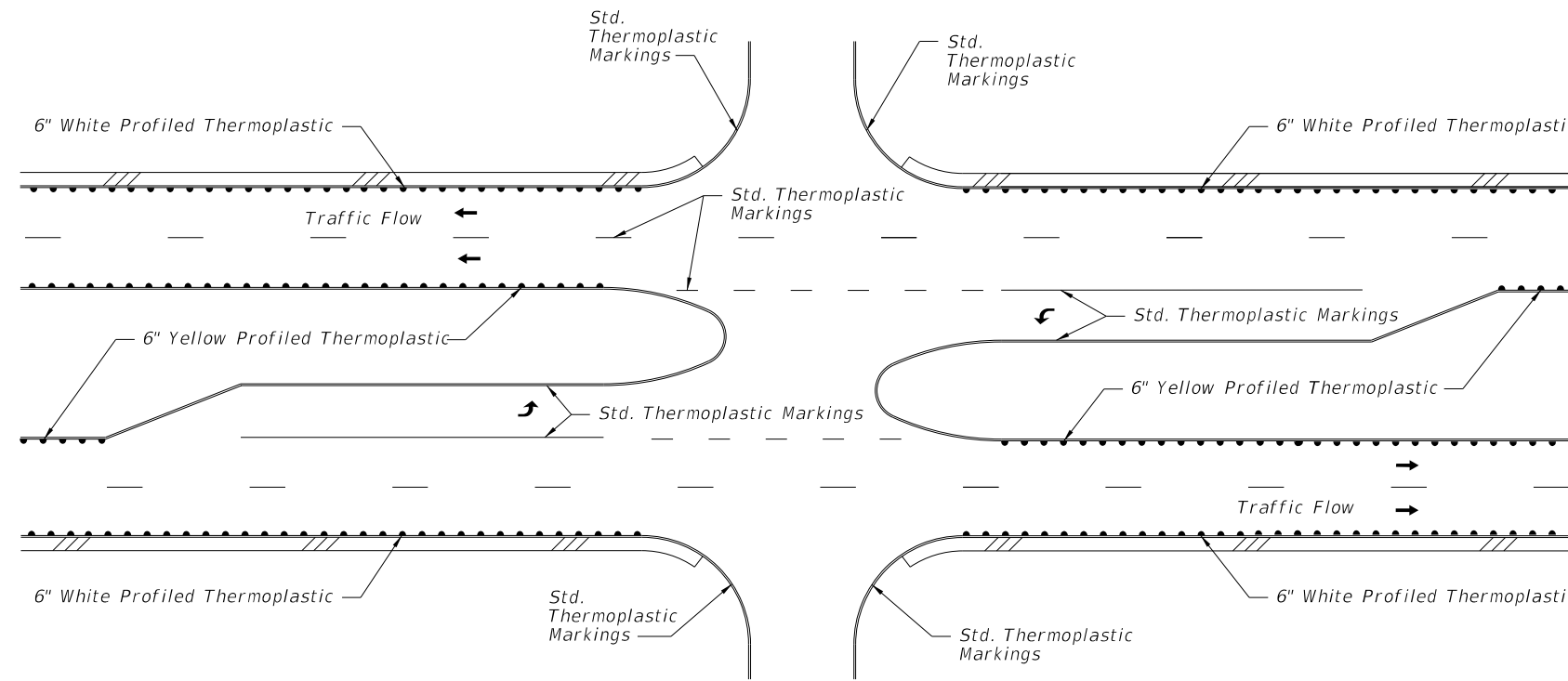

TYPICAL RURAL INTERSECTION

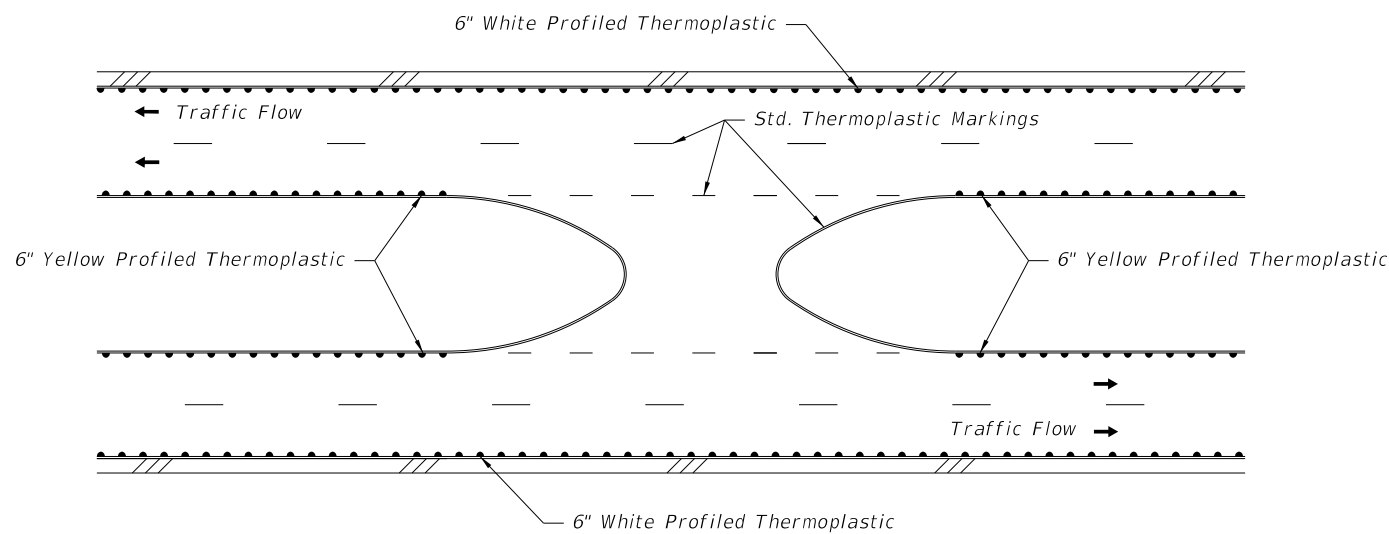

TYPICAL RURAL MEDIAN OPENING

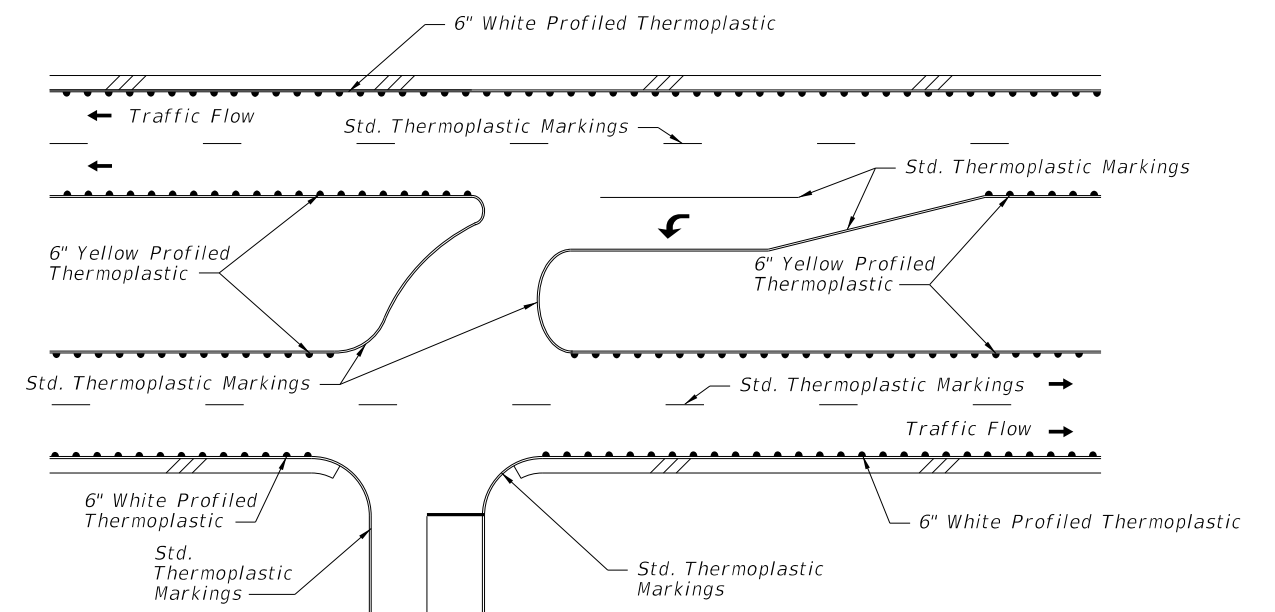

TYPICAL RURAL DIRECTIONAL INTERSECTION

PROFILED THERMOPLASTIC MARKINGS MULTI-LANE ROADWAYS

10/14/2016 8:38:29 AM

LAST REVISION 11/01/16	DESCRIPTION:	 FY 2017-18 DESIGN STANDARDS	PAVEMENT MARKINGS	INDEX NO. 17346	SHEET NO. 17 of 17
---------------------------	--------------	--	-------------------	--------------------	-----------------------